

JUNE 2020

TOWN OF WEAVERVILLE



ADA

transition plan



WithersRavenel

Our People. Your Success.

Adopted by Town Council: June 22, 2020

WithersRavenel

84 Coxe Avenue, Suite #260

Asheville, NC 28801

www.withersravenel.com

This document has been prepared by WithersRavenel





contents

- Introduction 2
- Public Outreach..... 3
- Plan Requirement 1: Identify Barriers 4
- Vertical Facilities 4
- Pedestrian Network Facilities 7
- Plan Requirement 2: Methods to Remove Barriers..... 14
- Vertical Facilities..... 14
- Pedestrian Network Facilities 20
- Plan Requirement 3: Specify a Schedule..... 22
- Plan Requirement 4: Identify an ADA Coordinator 28
- Future Steps 29
- Appendices..... 30

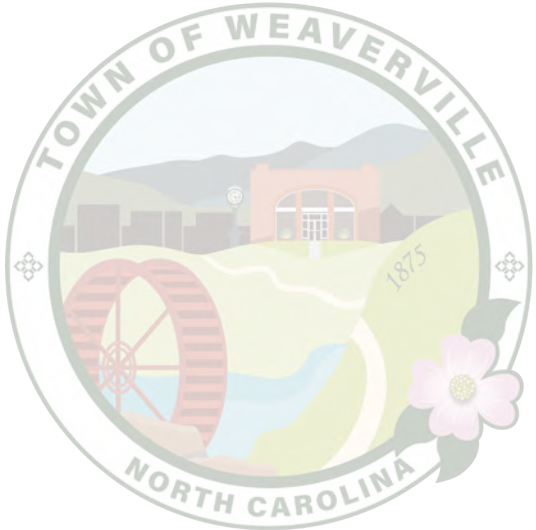



Under §35-150 of the ADA Title II Regulations, municipalities with 50 or more employees must establish an ADA Transition Plan. The general purpose of this plan is to ensure that all citizens have access to municipal facilities, programs, activities and services. This plan focuses on the architectural and physical barriers to access.

The Town of Weaverville is located in Buncombe County, North Carolina, and employs approximately 70 full-time employees. While infrastructure improvements have accompanied new development within the Town, municipal staff have noted that barriers to accessibility may be impacting the greater mobility of their approximate 4,000 citizens. The decision was made to complete a comprehensive review of the Town’s facilities in order to determine barriers to accessibility. In compliance with the ADA guidance on transition plans, this plan:

1. Identifies physical obstacles in the public entity’s facilities that limit the accessibility of its programs, services, and activities to individuals with disabilities;
2. Describes in detail the methods that will be used to make the facilities accessible;
3. Specifies the schedule for taking the steps necessary to achieve compliance with §35.150 of the ADA Title II Regulations over a period of 5 years; and
4. Indicates the official responsible for implementation of the plan.

To further compliance with the ADA, Weaverville’s Town Council amended the Town’s Americans with Disabilities Compliance Policy and Grievance Policy and Procedures in order to more clearly set out the policies and to provide a procedure to address issues that might arise concerning accessibility related to the ADA. These amendments were adopted on April 27, 2020, and may be found in Appendix A of this plan.

The Town has also adopted a Title VI Implementation Plan and will be conducting a self-evaluation of ADA accessibility pertaining to the programs, activities and services that are unrelated to architectural or physical barriers.

The estimated budgets and approximate schedule of remediation may be found beginning on page 21 of this document.

public outreach

As part of the requirements detailed in §35.150 of the Americans with Disabilities Act Title II Regulations, “A public entity shall provide an opportunity to interested persons, including individuals with disabilities or organizations representing individuals with disabilities, to participate in the development of the transition plan by submitting comments.”

The Town of Weaverville released a flyer to its citizens on April 29, 2020. The flyer described the intent of the Transition Plan as well as describing three distinct ways in which citizens would be able to comment on current accessibility conditions:

- » Written Comments could be provided via email, traditional mail, or submitted to a drop box located at Town Hall.
- » A telephone number was provided to schedule a conference call with the ADA Coordinator during the month of May.
- » Three Public Input Sessions were also announced for May 14th & May 27th. Due to COVID-19 safety procedures, two of the conferences were held via teleconference meetings, and the meeting IDs, weblinks, and phone numbers were included for public use. The non-virtual meeting was conducted at Town Hall utilizing proper social distancing practices.

A copy of the flyer may be found in Appendix B of this plan.





plan requirement 1: identify barriers

VERTICAL FACILITIES

The Town of Weaverville owns and operates several facilities that are open to the general public. Because these facilities are expected to host citizens of Weaverville, measures must be taken in order to ensure that all public-facing services within the buildings must be accessible for all. The following list details all municipal facilities open to the public within the Town of Weaverville:

- » Town Hall and Police Department - 30 S Main St, Weaverville, NC 28787
- » Fire Department - 3 Monticello Rd, Weaverville, NC 28787
- » Public Works Department - 15 Quarry Rd, Weaverville, NC 28787
- » Water Treatment Plant – 50 Sams Road, Weaverville, NC 28787
- » Lake Louise Park - Lake Louise Dr, Weaverville, NC 28787
- » Main Street Nature Park – 11 Pine Street, Weaverville, NC 28787

In order to effectively assess these facilities, field crews utilized the “ADA Checklist for Existing Facilities”, a set of resources that are promoted by the Department of Justice and the American Disabilities Act, and which are in line with the requirements of the 2010 American Disabilities Act Accessibility Guidelines (ADAAG). These reference checklists allowed field crew to holistically assess the Town’s facilities with detailed accuracy. In addition to the checklists, field crews were outfitted with a tablet equipped with a camera, measuring tape and an

electronic level for dimensional calculations and personal protective equipment for safety. Copies of the completed checklists may be found in Appendix C of this document.

At large, the Town of Weaverville’s vertical facilities contain few barriers to accessibility. Furthermore, many of the items identified by field crew would be considered simple changes that can be fixed relatively quickly and at nominal costs. While improvements to vertical facilities will be detailed in this plan, the ADA Coordinator must exercise sound judgement and decision making when it comes to vertical facility fixes. The coordinator may elect to employ procedural corrections as opposed to infrastructure improvements if public services are inaccessible.

Please see Tables 1-5 for a detailed list of failed facilities within Weaverville:

Table 1: Town Hall/Police Department Barriers	
Checklist Item	Failure Description
1.2 - 1.5, 1.9 & 1.10	Lack of accessible parking.
2.31	Door signs not mounted between 48" and 60" above the floor.
3.2	No signs at inaccessible toilets directing public to accessible toilets.
3.11	Male/female accessible bathroom doors require excessive force to open.
3.20	Accessible stall's coat hooks set too high.

Table 2: Fire Department Barriers	
Checklist Item	Failure Description
2.45	Doors to building's public entrance require excessive force to open.
3.11	Male/female accessible bathroom doors require excessive force to open.
3.20	Accessible stall's coat hooks set too high.
3.23	Male/female bathroom sinks are installed at an inaccessible height.
3.32	Male/female toilets are installed at an inaccessible height.
3.44	Adequate door pulls not present on both sides of male/female stall doors.
4.60	Water fountain spout is too high for accessible use.



Table 3: Public Works Department Barriers

Checklist Item	Failure Description
3.12	Closer for male/female bathrooms closes too quickly and is considered inaccessible.
3.26	Pipes below male/female sinks are not insulated or protected.
3.34	Rear grab bar in male/female bathrooms is not 36" long.
4.9	Water fountain protrudes into circulation path at an unsafe height.
4.20	Fire alarm does not include strobe lights.

Table 4: Water Treatment Plant Barriers

Checklist Item	Failure Description
1.3	No van-accessible space located at the plant.
1.9	No curb ramp access from the parking lot to the building.
(Various)	No accessible bathrooms exist on the first floor. Second floor accessible only by stairs.

The Town of Weaverville’s Water Treatment Plant is not normally open to the public. However, the Town hosts an annual Citizen’s Academy that educates citizens on the workings of town government. This Citizen’s Academy will tour the Water Treatment Plant as part of one of the sessions. Because of this unique situation of public access into an otherwise restricted area, the Water Treatment Plant was assessed in a unique manor. The field surveyor met with the Water Superintendent, and was led on the walking tour of the facility. The surveyor assessed all facilities that the Citizen’s Academy would interact with and conducted a limited accessibility analysis based on the tour path.

The Town of Weaverville has previously acknowledged that the Lake Louise Park bathrooms were both antiquated and not fully accessible. Because of this, these facilities are scheduled to be demolished. New ADA compliant bathrooms are expected to be constructed within the year. Because of this, bathroom facilities for the park were not surveyed. Reconstruction of these bathrooms will be needed in order to achieve accessibility at this location.

Additionally, as a part of its community fishing program, the NC Wildlife Resources Commission recently installed an accessible fishing pier at the southern end of Lake Louise. This pier represents a forward-thinking approach to recreational equality, and the Town supported this effort by adding an accessible parking stall to its existing parking lot in this area.



Figure 1: Lake Louise Bathrooms



Figure 2: Accessible Fishing Pier

The Town’s Main Street Nature Park is developed and maintained to provide a more natural condition and protect the area’s wildlife. As such, the park maintains a natural sloping topography and is maintained with mulched footpaths and gravel. It offers guests a place to get away from paved facilities, and to lose themselves in the natural environment.

As part of 36 CFR Part 1191 RIN 3014-AA22: Architectural Barriers Act Accessibility Guidelines; Outdoor Development Areas, it is asserted that the Main Street Nature Park would be exempt from accessibility under the conditions that Compliance would fundamentally alter the function or purpose of the facility or setting. It is argued that paving or reconstruction of the existing trails would impact the physical aesthetic, and therefore importance of the park’s function.

Table 5: Lake Louise Park	
Checklist Item	Failure Description
P1 & P2	Swings do not contain an accessible route.
P20	Circular handrail surface exceeds grip diameter.
1.4 - 1.11	Northern lot accessible parking barriers
1.27	Ramp running slope is too steep.

PEDESTRIAN NETWORK FACILITIES

In order to create an efficient inventory and ultimately design an effective ADA Transition Plan, municipal staff worked with WithersRavenel personnel to conduct a holistic analysis of the Town’s pedestrian network. Consulting staff conducted a “boots on the ground” assessment of features including items such as ramp slope, presence of detectable domes, sidewalk slope, even landing pads, proper cross walk striping, etc.

To make this field survey more efficient, survey crews leveraged the network’s curb ramps inventory as survey anchor points, conducting analysis of infrastructure health from each ramp. The Town of Weaverville contains approximately 146 curb ramps. Figure 3 depicts the survey points utilized during the pedestrian facilities field analysis.

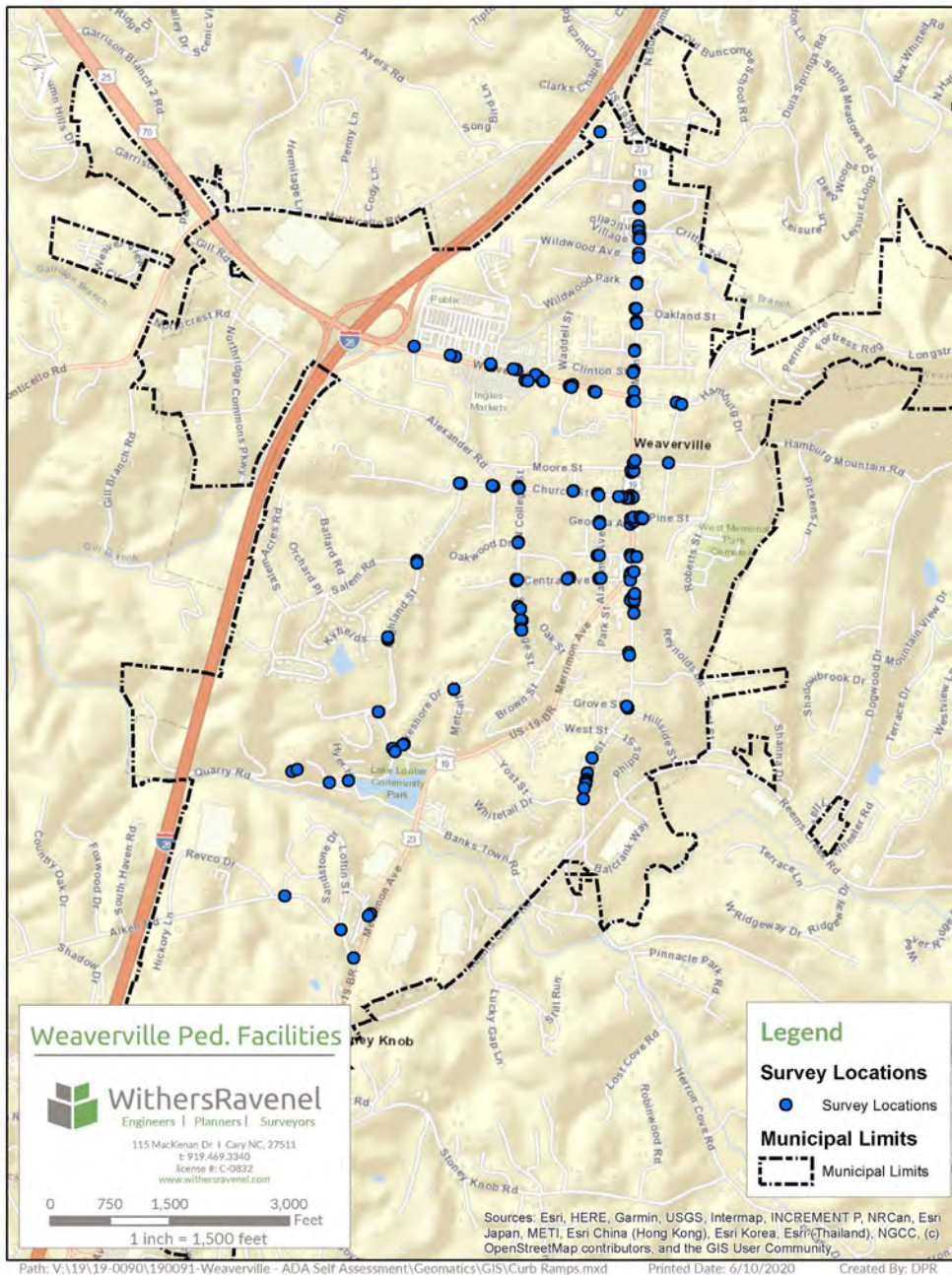

Additionally, The Town of Weaverville staff and WithersRavenel personnel worked together in order to create an effective field assessment tool that survey crews could reference on-site and collect all pertinent data in a georeferenced, uniform manner. Consulting staff employed the use of Collector for ArcGIS, a software designed to be integrated into electronic tablet use so that field crews may collect accurate data on-site. Field crews were outfitted with a tablet equipped with Collector software and capable of georeferencing pictures taken during the assessment, measuring tape and an electronic level for dimensional calculations and personal protective equipment for safety. The field survey reference can be found in Appendix D of this document.

Figure 3: Survey Locations Map

Field surveys were conducted between 04/15/2020 & 05/22/2020. Crews were instructed to take a georeferenced photograph of each violation and each curb ramp within the Town, and log all information on their tablet. During field analysis, crews logged 94 locations that would be considered barriers to ADA accessibility. Curb ramp infrastructure was surveyed as a single point containing multiple qualities that could each be interpreted as a barrier to accessibility. For example, a single curb ramp could be less than 4 feet wide (1st violation), lack detectable warning domes (2nd violation), and have a cross slope greater than 2% (3rd violation). This would result in the curb ramp as a whole being considered a failing piece of, not 3 separate failures. Figure 4 depicts the overall pass/fail conclusion for the 146 survey areas assessed.

It is important to note that, while 94 of 146 locations resulting in one or more failures is significant, it is not necessary a testament to the Town's infrastructure quality. As with many regulations, the requirements and practices of curb ramp, sidewalk, and cross walk design have evolved over the years. What was considered a best practice in 1990 is not the same as today. Therefore, it is recommended that the Town's Public Works Department approach pedestrian network remediation via location priority and not failure conditions. This allows the Town to exercise sound judgment in remediation of important, widely-used locations rather than the spot repair of points with the most logged failures.

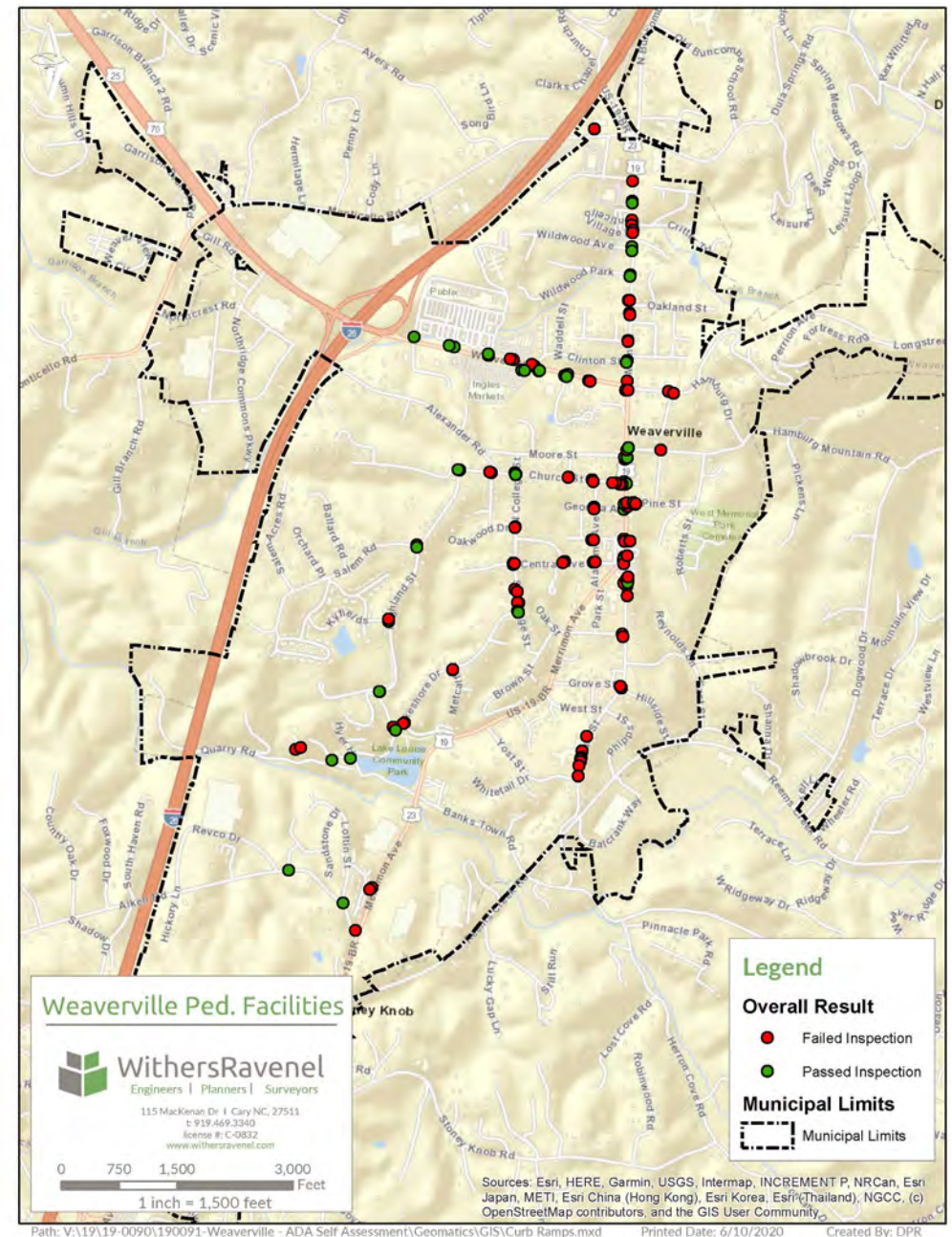

Figure 4: Pass/Fail Conclusion

Additional network figures can be found in APPENDIX E of this document.

ADA TRANSITION PLAN

While the field survey list is intended to be comprehensive, barriers to access can appear in plethora of ways, some unforeseen. The following images depict some of the findings of the field survey that can help illuminate the survey findings.



Figure 5: Sufficient Features

Figure 5 above depicts many of the positive features that field crews are looking for in the pedestrian network. There are clearly detectable domes present at the curb ramp. The ramp is flush with the road crossing and clear striping is present. Slopes are smooth and not excessive and sidewalk slabs are flush with one another.



Figure 6: Barrier Example

Figure 6 depicts a few issues that count as barriers to access. For starters, there are no detectable domes present at the ramp. The ramp also does not lead to a level 4-foot by 4-foot landing, making it difficult for those using a wheelchair to ascend. Additionally, the ramp itself directs the user leaving the sidewalk directly into the street instead of towards the next ramp.



Figure 7: Barrier Example

Many factors in Figure 7 are correct. There is a wide sidewalk with a gentle running slope and cross slope and the ramp leads directly across the driveway. However, two main issues stand out with this example; 1. There are no domes. 2. The running slope of the ramp is much steeper than the 1:12 ratio required for accessibility.



Figure 8: Barrier Example

Figure 8 demonstrates the challenges of uneven landing lips. Navigation using a wheelchair across the above curb would represent a great challenge for some.



Figure 9: Barrier Example

Figure 9 reiterates many of the factors seen before but exemplifies the lack of a level 4-foot by 4-foot landing pad at the top of the ramp. Users using a wheelchair would ascend this ramp directly into the grass at the top. There is no directional design.



Figure 10: Barrier Example

While the features in Figure 10 appear level, the narrow sidewalk and obstructions due to the utility pole and mailbox may prevent wheelchair users from navigating this section of the network as the width reduction may be too great.

These examples help lend insight into the field survey process and the varied nature of barriers that can be found throughout the Town’s network. Table 6 details the barrier counts that were identified within the Town network.



Table 6: Failed Facilities

Checklist Item	Failure Description
Curb ramp direction does not lead to crossing	13
Uneven Landing	70
Less than 4-Foot width	21
Greater than 8.3% running slope	10
More than 2% cross slope	16
No 2-foot side detectable warning domes or other materials	50
No 4 x 4 level at top of curb ramp	19
4 x 4 landing not level	16
Curb ramp flares exceed max slope	10
Physical obstructions	5



plan requirement 2: methods to remove barriers

Table 7: Town Hall/Police Department Barriers

Checklist Item	Failure Description	Recommend Removal
1.2 - 1.5, 1.9 & 1.10	Lack of accessible parking.	See Note #1
2.31	Door signs not mounted between 48" and 60" above the floor.	*Adjust signs to be between 48" and 60" from floor.
3.2	No signs at inaccessible toilets directing public to accessible toilets.	Add Signs directing public towards accessible bathroom.
3.11	Male/female accessible bathroom doors require excessive force to open.	Adjust closer or replace door so force needed does not exceed 5 lbs.
3.20	Accessible stalls' coat hooks set too high.	Adjust hooks between 25" and 48" on stall.

**Item does not need intervention if the building was constructed before 03/15/2012, as parameter was not required in the 1991 Standards.*

VERTICAL FACILITIES

The "ADA Checklist for Existing Facilities" is not only an excellent resource for barrier identification, but it also provides users with recommended barrier removal techniques for each failed facility. That being noted, it is recommended that a licensed contractor review

the following failed facilities in-person in order to provide accurate insight and expected costs for barrier removal. Tables 7-11 detail the recommended barrier removal actions for each Town facility:



Figure 11: Office Entrance

Note #1: The Town Hall/Police Department currently has several spots dedicated as accessible parking spaces. However, only one of the spots allows for public access into the building. The parallel parking space designated as accessible at the building's front leads directly into a raised curb, with no access aisle leading to the nearest curb ramp, which itself is not compliant with contemporary standards. Additionally, the southern designated spaces at the building's rear leads directly to an officer only entrance (see Figure 11).

The Town Hall building should have 2 additional accessible parking spots with one being a van-accessible spot. Due to the topography of the site, achieving these two spaces provides a difficult challenge. It is recommended that the Town restripe the southern parking stall at the building's rear to lead to the lower public entrance where the existing compliant stall currently leads. Additionally, it is recommended that the Town redesign the current parallel parking stall at the main entrance to be compliant with current standards.



Table 8: Fire Department Barriers

Checklist Item	Failure Description	Recommend Removal
2.45	Doors to building's public entrance require excessive force to open.	Adjust closer or replace door so force needed does not exceed 5 lbs.
3.11	Male/female accessible bathroom doors require excessive force to open.	Adjust closer or replace door so force needed does not exceed 5 lbs.
3.20	Bathroom coat hooks set too high.	Adjust hooks between 25" and 48" on stall.
3.23	Male/female bathroom sinks are installed at an inaccessible height.	Reinstall sinks so that they are no more than 34" above the ground.
3.32	Male/female toilets are installed at an inaccessible height.	Adjust toilet height so that it is between 17" & 19" from the ground.
3.44	Adequate door pulls not present on both sides of male/female stall doors.	*Replace door handles and hardware.
4.60	Water fountain spout is too high for accessible use.	Adjust water fountain so that the spout outlet is no higher than 36" from ground.

**Item does not need intervention if the building was constructed before 03/15/2012, as parameter was not required in the 1991 Standards.*





Table 9: Public Works Department Barriers

Checklist Item	Failure Description	Recommend Removal
1.5	Northeastern accessible space did not meet the dimensions required by van accessible parking spaces.	Restripe the parking lines to achieve an 11' space with a 5' aisle or consider striping lot next to existing compliant lot. Add signage.
3.12	Closer for male/female bathrooms closes too quickly and is considered inaccessible.	Adjust closer so that the doors take at least 5 seconds to close from a 90-degree angle.
3.26	Pipes below male/female sinks are not insulated or protected.	Install insulation or a cover panel.
3.34	Rear grab bar in male/female bathrooms is not 36" long.	*Install 36" rear grab bar appropriately.
4.9	Water fountain protrudes into circulation path at an unsafe height.	Add a tactile warning such as permanent planter or partial wall to screen fountain.
4.20	Fire alarm does not include strobe lights.	Replace fixture.
4.60	Water fountain spout is too high for accessible use.	Adjust water fountain so that the spout outlet is no higher than 36" from ground.

**Item does not need intervention if the building was constructed before 03/15/2012, as parameter was not required in the 1991 Standards.*

Table 10: Water Treatment Plant Barriers

Checklist Item	Failure Description	Recommend Removal
1.3	No van-accessible space located at the plant.	Reconfigure to provide van-accessible space. Add signage. (See Note #2)
1.9	No curb ramp access from the parking lot to the building.	Install curb ramp into building. (See Note #2)
(Various)	No accessible bathrooms exist on the first floor. Second floor accessible only by stairs.	See Note #2

Note #2: As mentioned above, the Water Treatment Plant is only accessible to the public once a year via the Citizen’s Academy. As such, the facility does not contain many barriers to public accessibility in relation to the tour path that the academy members would utilize. However, the largest barrier to accessibility within the Treatment Plant is the lack of an accessible bathroom on the ground level of the building. Due to the significant costs associated with the construction of a ground level bathroom, it is not recommended that the Town pursue this option for barrier removal.

Instead, it is recommended that the Water Superintendent conduct the tour through the facility via a narrated and filmed walkthrough of the tour limits. During the Citizen’s Academy rotation of the Water Treatment Plant, it is recommended that the academy be scheduled to meet at a common area, perhaps Town Hall, and watch the filmed walkthrough of the facility. The Water Superintendent should also be present at that academy meeting and help answer any questions that may arise during the film. This in turn would limit all public interaction with the Water Treatment Plant and remove the need to make a costly addition to the facility.



Table 11: Lake Louise Park Barriers		
Checklist Item	Failure Description	Recommend Removal
P1 & P2	Swings do not contain an accessible route.	Construct accessible route.
P20	Circular handrail surface exceeds grip diameter.	Replace with 0.94" to 1.55" diameter rails.
1.4 - 1.11	Northern lot accessible parking barriers	See Note #3
1.27	Ramp running slope is too steep.	See Note #4

Note #3: The Lake Louise Park parking lot contains a multitude of accessibility barriers. The three accessible parking spaces in the northern lot all lack proper striping, dimensioning, and signage. Moreover, the slope of the lot exceeds the allowable slope limit for proper navigations and the parking leads directly to a raised obstruction. It is recommended that the Town work with a consultant to provide planning and design services for the grading, restriping, and accessibility planning of the parking lot to achieve compliance.

Note #4: Field survey found that the running slope of the ramp located adjacent to the northern parking exceed the maximum slope. As such, it is recommended that this ramp be retrofitted by the Public Works Department in order to achieve the required slope of 1:12. Additionally, field staff found that the ramp was obstructed midway down the ramp with a board replacement project (see Figure 12).

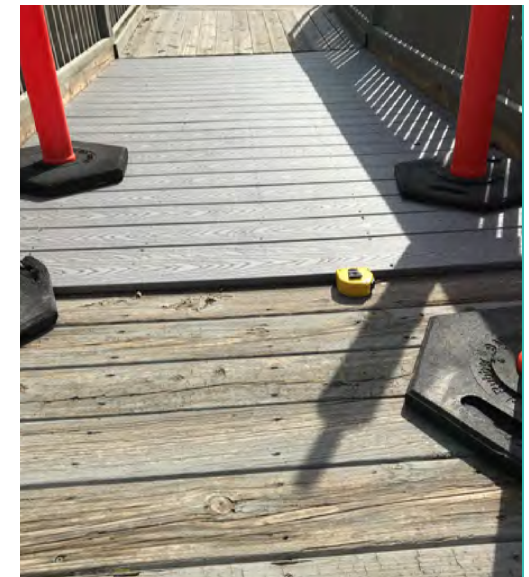

Figure 12: Additional Ramp Obstruction



PEDESTRIAN NETWORK FACILITIES

Staff identified the following remediation methods for the barriers within the Weaverville Network:

Table 12: Failed Pedestrian Network Facilities

Failed Facility	Failure Count	Barrier Removal
Curb ramp direction does not lead to crossing	13	Realign Crosswalk Markings/Reconstruct Ramp
Uneven Landing	70	Sawcut
Less than 4-Foot width	21	Reconstruction
Greater than 8.3% running slope	10	Replace/Level Ramp
More than 2% cross slope	16	Replace/Level Ramp
No 2-foot side detectable warning domes or other materials	50	Add domes
No 4 x 4 level at top of curb ramp	19	Add/Replace 4x4
4 x 4 landing not level	16	Level Landing
Curb ramp flares exceed max slope	10	Replace Flares
Physical obstructions	5	Remove Obstruction

It is important to note that multiple remedial efforts are consolidated when reconstruction is conducted.

Additionally, the surveyor noted that several areas of the sidewalks on Merrimon Avenue in downtown Weaverville contained items such as chairs, tables, and signs, that could be an impediment to accessibility depending on the use and exact location of such items. Town ordinances should be reviewed in order to determine whether provisions related to sidewalks and code enforcement are adequate to keep the public sidewalks in the Town ADA accessible up to a minimum width of 48 inches. The Town could also consider adopting a program to identify the boundary of the ADA accessible area of those sidewalks so that voluntary participation could be more easily encouraged.



plan requirement 3: specify a schedule

With an understanding of Town barriers and a strategy to remove them, the next step in this plan is to establish a schedule of remediation. Of course, remediation does not happen in a vacuum and is therefore subject to Town budgets and the economy. With the recent financial impacts of the COVID-19 outbreak, it will be difficult to estimate project costs and budgets in the future. Town of Weaverville staff orchestrating these remedial efforts will need to closely track the costs and project budgets in order to define estimates through each fiscal year. For the purposes of establishing a schedule, remediation costs will be generalized into five broad categories:

Table 13: Budget Categories

Category	Estimated Cost	Funding Description
"\$"	\$0 - \$999	Maintenance Funds
"\$"	\$0 - \$999	Citizen Requests Funds
"\$\$"	\$1,000 - \$4,999	ADA Remedial Funds
"\$\$\$"	\$5,000 - \$9,999	ADA Transition Plan Special Funding
"\$\$\$\$"	\$10,000 and Up	Capital Improvement Plan Candidates



- » **Maintenance Funds (\$)** – Obstruction removal requiring these funds is typically done quickly and utilize municipal staff for labor. Generally, these projects can utilize the municipality’s existing maintenance budget, as these fixes are low cost. Examples of remediation efforts include adjusting door pulls, insulation of pipes and the addition of ADA parking signs.

- » **Citizen Request Funds (\$)** – While not directly associated with specific accessibility barriers, these funds should be set aside on a yearly-basis upon plan approval. The intent of this budget is to have a small portion of money set aside by the municipality that can be used as new barriers to accessibility are identified by Weaverville citizens via Grievance Procedures Policy. The Town’s ADA Coordinator will be in charge of using this budget to address any emergent barriers as they see fit.
- » **ADA Remedial Funds (\$\$)** – These accessibility barriers will require more time and money than the previous category, and have the potential to utilize private contractors or special materials. Funding for these barriers will need to be planned for at least a year in advance of the work. Planned projects for the following fiscal year can be itemized in the General Fund. Examples of such remedial projects include installation of new pedestrian signals, parking lot re-stripping projects and construction of new pedestrian ramps.
- » **ADA Transition Plan Special Funding (\$\$\$)** – Special funding projects will need some degree of specialized materials or consultant assistance. Therefore, they will be more expensive than the previous examples of barrier removal. These projects will most likely rely on the work of the municipal staff to identify unique grant or funding opportunities from external sources in order to develop the project budget to remove these barriers. Examples of work requiring special funding would be the construction of new bathroom facilities or constructing accessible playground equipment.
- » **Capital Improvement Plan Candidates (\$\$\$\$)** – Projects that fall into this category will require long-range planning, consulting efforts and specialized materials in order to remove the accessibility barriers they address. Therefore, these projects are perfect candidates for the municipality’s Capital Improvements Plan. Remedial efforts in this category could include projects undertaking large amounts of grading and paving materials.

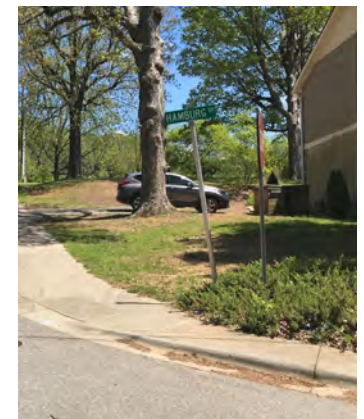
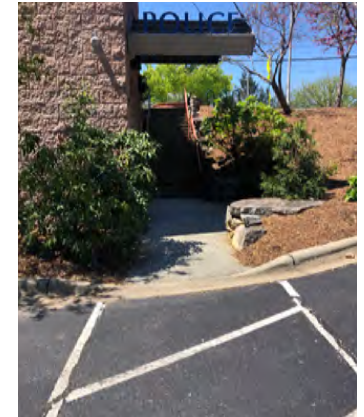

Additionally, the pedestrian facility survey identified 94 failed curb ramp locations throughout the Town. The schedule will assume that, utilizing the ADA Transition Special Funding each fiscal year, the 94 pedestrian facilities will be remediated over the course of the next five years at about 19 facility remediations per year. The ADA Coordinator must work closely with Town staff in order to determine timeline and budget adjustments related to pedestrian facility work due to the varied nature of repairs and funding availability.

Table 14: ADA Transition Plan Schedule

FY 2021				
Town Hall				
3.2	\$	Maintenance Fund	Add Signs directing public towards accessible bathroom.	
3.11	\$	Maintenance Fund	Adjust closer or replace door so force needed does not exceed 5 lbs.	
Fire Department				
2.45	\$	Maintenance Fund	Adjust closer or replace door so force needed does not exceed 5 lbs.	
3.11	\$	Maintenance Fund	Adjust closer or replace door so force needed does not exceed 5 lbs.	
3.44	\$	Maintenance Fund	*Replace door handles and hardware.	
Public Works Department				
3.12	\$	Maintenance Fund	Adjust closer so that the doors take at least 5 seconds to close from a 90-degree angle.	
4.20	\$	Maintenance Fund	Replace fire alarm fixture to include strobe lights.	
Water Treatment Plant				
Various	\$	Maintenance Fund	Film narrated tour of facility to present to Citizen's Academy. Cease conducting tours.	
Road Network				
Annual	\$\$\$	ADA Transition Plan Special Funding	Location priority: Central and Northern Main Street	
Citizen Requests				
Per Request	\$	Citizen Request Fund	Spot fixes as they arise through the Grievance Procedures.	

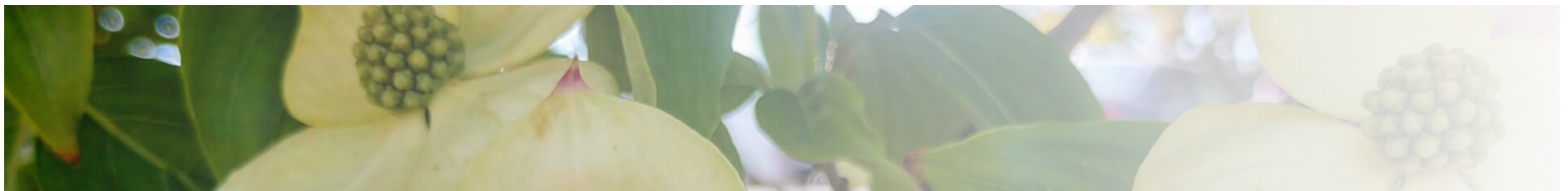

Table 14: ADA Transition Plan Schedule

FY 2022				
Town Hall				
3.20	\$	Maintenance Fund	Adjust stall hooks between 25" and 48" for male/female bathrooms.	
Fire Department				
3.20	\$	Maintenance Fund	Adjust stall hooks between 25" and 48" for male/female bathrooms.	
4.60	\$	Maintenance Fund	Adjust water fountain so that the spout outlet is no higher than 36" from ground.	
3.23	\$\$	ADA Remedial Funds	Reinstall male/female sinks so that they are no more than 34" above the ground.	
Public Works Department				
3.26	\$	Maintenance Fund	Install insulation or a cover panel under male/female sinks.	
3.34	\$	Maintenance Fund	*Install 36" rear grab bar appropriately.	
4.9	\$	Maintenance Fund	Add a tactile warning such as permanent planter or partial wall to screen water fountain.	
Lake Louise Park				
P1 & P2	\$\$	ADA Remedial Funds	Construct accessible route to swing set facility.	
Road Network				
Annual	\$\$\$	ADA Transition Plan Special Funding	Location priority: Central and Northern Main Street	
Citizen Requests				
Per Request	\$	Citizen Request Fund	Spot fixes as they arise through the Grievance Procedures.	



Table 14: ADA Transition Plan Schedule

FY 2023				
Town Hall				
2.31	\$	Maintenance Fund	*Adjust signs to be between 48" and 60" from floor.	
3.20	\$\$\$	ADA Transition Plan Special Funding	Parallel parking and restriping project.	
Fire Department				
3.32	\$\$	ADA Remedial Funds	Adjust toilet heights so that they are between 17" & 19" from the ground.	
Lake Louise Park				
P20	\$\$	ADA Remedial Funds	Replace access handrails to vertical play facility with .094" to 1.55" diameter rails.	
Road Network				
Annual	\$\$\$	ADA Transition Plan Special Funding	Location priority: Northern Main Street & Weaver Boulevard	
Citizen Requests				
Per Request	\$	Citizen Request Fund	Spot fixes as they arise through the Grievance Procedures.	

Table 14: ADA Transition Plan Schedule

FY 2024				
Lake Louise Park				
Annual	\$\$\$	ADA Transition Plan Special Funding	Prepare RFP for Parking Grading/Restriping Project.	
Road Network				
Annual	\$\$\$	ADA Transition Plan Special Funding	Location priority: Church Street, Alabama Avenue, & College Street	
Citizen Requests				
Per Request	\$	Citizen Request Fund	Spot fixes as they arise through the Grievance Procedures.	

Table 14: ADA Transition Plan Schedule

FY 2024				
Lake Louise Park				
Annual	\$\$\$	ADA Transition Plan Special Funding	Reconfigure ramp slope to allow for 1:12 maximum running slope.	
Road Network				
Annual	\$\$\$	ADA Transition Plan Special Funding	Location priority: Remaining locations	
Citizen Requests				
Per Request	\$	Citizen Request Fund	Spot fixes as they arise through the Grievance Procedures.	

**Item does not need intervention if the building was constructed before 03/15/2012, as parameter was not required in the 1991 Standards.*

Project priorities may change as costs and budgets shift, or as new citizen requests emerge. The schedule above is meant only to serve as a guideline for staff to reference when planning for future system improvements. As improvements are made over the years, it is anticipated that the ADA Transition Improvement funds will shift from planned spot fixes towards funding citizen requests. Additional route projects may be identified by staff in the future as well, in which they will be planned for on the Capital Improvement Plan and added to this schedule.





plan requirement 4: identify an ADA Coordinator

The ADA Transition Plan requires the identification of an individual with the municipality who will carry out said plan. This individual will be responsible for:

- » Coordinating barrier removal per the allocated budget and schedule.
- » Working to get larger comprehensive route projects onto the Capital Improvement Plan.
- » Implementing a grievance procedure that allows citizens to request barrier removal.
- » Creating an investigation procedure in order to handle citizen requests.
- » Conducting staff/volunteer training on ADA compliance.
- » Identifying and contact potential partner organizations to work with.
- » Implementing future steps as identified and listed in document.
- » Conducting self-evaluation of the plan and listed procedures.

The Town of Weaverville has selected the following individual as ADA Coordinator:



JENNIFER JACKSON

30 South Main Street

(828) 645-7116

compliance@weavervillenc.org

jjackson@weavervillenc.org



future steps

The ADA Coordinator shall continue to pursue Town-wide accessibility by conducting the following actions:

- » Work with Town departments to determine remedial effort costs and begin developing yearly budgets for funding sources.
- » Identify field staff who are well equipped to continue to monitor sidewalks and curb ramps during their daily responsibilities.
- » Work to begin identifying funding opportunities for remediation.
- » Work to reassess the plan and barrier inventory on a yearly basis to ensure proper budgeting and project prioritization.
- » Develop a schedule to evaluate municipal programs and electronic resources for potential access barriers.
- » Establish a semi-annual schedule to assess Lake Louise Park pathways for erosion and gravel disturbance.

If you have any questions concerning this plan, please contact **Jennifer Jackson** at compliance@weavervillenc.org.





ADA TRANSITION PLAN
JUNE 2020

APPENDIX A:

**Americans with Disabilities
Compliance Policy and
Grievance Policy, and
Procedures Approved
Amendments**

TOWN OF WEAVERVILLE
RESOLUTION AMENDING THE TOWN'S ADA COMPLIANCE POLICY AND THE
GRIEVANCE POLICY AND PROCEDURES

WHEREAS, Part 4 of Article 7 of Chapter 160A of the North Carolina General Statutes sets forth certain requirements and provides certain authority to Town Council regarding its employees and the establishment of policies regarding its employees; and

WHEREAS, Town Council wishes to make clear policy statements with regard to compliance with the Americans with Disabilities Act and provide a process whereby discrimination under the Act can be brought to the Town's attention for resolution;

NOW, THEREFORE, BE IT RESOLVED BY THE TOWN OF WEAVERVILLE, NORTH CAROLINA, ACTING THROUGH ITS COUNCIL MEMBERS, AS FOLLOWS:

1. Town Council hereby amends and restates the **AMERICANS WITH DISABILITIES COMPLIANCE POLICY** that is shown as Tab 5 of the Policy and Procedures Manual, with the attached policy effective immediately.
2. Town Council hereby amends and restates the **GRIEVANCE POLICY AND PROCEDURES** that is shown as Tab 6 of the Policy and Procedures Manual that is attached, with the attached policy effective immediately.
3. This resolution shall become effective immediately.

ADOPTED this 27th day of April, 2020.



ALLAN P. ROOT, Mayor



ATTEST:



DEREK K. HUNINGHAKE, Town Clerk

TOWN OF WEAVERVILLE AMERICANS WITH DISABILITIES COMPLIANCE POLICY

Section 1. Purpose and Objectives

It is the policy of the Town to afford equal employment opportunity to all qualified individuals with disabilities as defined in the Americans with Disabilities Act (ADA) and the Americans with Disabilities Act Amendment Act (ADAAA) in all employment-related decisions. As part of this policy, the Town will work to seek reasonable accommodations for applicants in the employment process, qualified employees with disabilities and for applicants with disabilities who have been offered employment.

The Town has long recognized that its employees are its most valuable asset. Accordingly, it is Town policy to support employees and candidates affected by mental or physical impairments, which may limit their opportunities to be productive. It is the Town's intent to provide support and assistance, consistent with the Americans with Disabilities Act and business demands, within reason, to qualified individuals who are disabled. As appropriate, the Town will attempt to eliminate barriers to employment in order to afford all individuals opportunities to pursue available employment to the extent of their abilities and talents.

The cooperation of all employees is expected and necessary to make this policy a reality. Employees with questions about this policy, reasonable accommodation, or who feel they have been treated unfairly because of a disability, perceived disability, or record of a disability should contact the ADA Coordinator as designated in this policy.

In addition to assuring compliance with the ADA in its employment practices, it is the policy of the Town to prohibit discrimination against qualified individuals with disabilities on the basis of disability in the Town's provision of services, programs and activities.

Section 2. Definitions

ADA – Includes collectively the Americans with Disabilities Act of 1990 and the Americans with Disabilities Act Amendment Act of 2008, and any subsequent amendments thereto.

Communicable disease – An illness due to an infectious agent or its toxic products which is transmitted directly or indirectly to a person from infected person or animal through the agency of an intermediate animal, host or vector, or through the inanimate environment, pursuant to NCGS 130A-133(1). The term shall include, but is not limited to: acquired autoimmune deficiency syndrome (“AIDS”), AIDS-related complex, human immunodeficiency virus (“HIV”) infection, hepatitis A, B, or C, and tuberculosis.

Direct threat to safety – A significant risk to the health or safety of the individual or others that cannot be eliminated by reasonable accommodation.

Disability – A person is “disabled” under this policy if that person has a physical or mental impairment that substantially limits him or her in one or more major life activities.

Essential job function – The basic job duties that an employee must be able to perform in his or her assigned job, with or without reasonable accommodation. Factors to be considered in determining if a function is essential include: (a) whether the reason the position exists is to perform that function, (b) the number of other employees available to

TOWN OF WEAVERVILLE AMERICANS WITH DISABILITIES COMPLIANCE POLICY

perform that function or among whom the performance of the function can be distributed, (c) the degree of expertise or skill required to perform the function, (d) the time spent performing a function, and (e) the consequences of not requiring that an employee perform a function.

Qualified individual with a disability – An employee or candidate with a disability who has the necessary skill, education, experience, and other job-related requirements to perform the essential functions of a position with or without a “reasonable accommodation.”

Reasonable accommodation –

Reasonable accommodation is any modification or adjustment to a job, job schedule or the work environment that will enable a qualified candidate or employee with a disability to participate in the application process or to perform essential job functions, or enjoy other benefits of employment without imposing an undue hardship on the Town or imposing a direct threat of safety to the individual or others in the workplace.

Examples of reasonable accommodation may include modifying existing facilities used by employees readily accessible to and usable by an individual with a disability; restructuring a job; modifying work schedules; acquiring or modifying equipment; providing qualified readers or interpreters; or appropriately modifying examinations, training, or other programs.

Reasonable accommodation may also include reassigning a current employee to a vacant position for which the individual is qualified if the person is unable to do the original job because of a disability even with an accommodation and no other accommodations exist. However, there is no obligation to find or create a position as an accommodation. The Town is not required to lower quality or quantity standards as an accommodation, nor is it obligated to provide personal use items such as glasses or hearing aids. The Town is not required to reallocate essential job functions of a job as a reasonable accommodation.

Undue hardship – The point at which an accommodation would be unduly costly, extensive, substantial or disruptive, or would fundamentally alter the nature or operation of the business.

Section 3. ADA Coordinator

The Town has designated the Town Manager, or designee, to handle issues related to the ADA. All requests for reasonable accommodation, auxiliary communication aids and services, alternative accessible formats for notices, policies, and other information, as well as complaints regarding the Town’s ADA program should be directed to the ADA Coordinator as follows:

TOWN OF WEAVERVILLE AMERICANS WITH DISABILITIES COMPLIANCE POLICY

ADA Coordinator

Weaverville Town Hall
30 South Main Street
Weaverville, NC 28787
828-645-7116

coordinator@weavervillenc.org

Section 4. Complaint Procedures

Complaints of alleged discrimination on the basis of disability by the Town may be filed by job applicants, employees, and former employees members of the general public, by using the grievance procedures set forth in Article XV of the Town's Personnel Policy. Members of the general public who feel that they have been discriminated against on the basis of disability may utilize the Grievance Policy and Procedures adopted by Town Council to file a disability related discrimination complaint.

The grievance procedures shall be distributed to members of the general public upon request for persons with disabilities. Any complaints relating to the ADA shall be considered confidential and kept separate from an employee's personnel file.

Section 5. No Retaliation

Individuals who oppose any act or practice that is unlawful under any title of the ADA, or who make a charge, testify, assist, or participate in any investigation, proceedings, or hearing under the ADA will not be retaliated against, nor will they be coerced, intimidated, threatened, or interfered with in the exercise or enjoyment of any ADA right. Job applicants or employees who may have a friend, associate, or family member with a disability are also covered by this ADA nondiscrimination policy pursuant to the ADA.

Section 6. Communicable Diseases

The Town shall not exclude from employment, participation in programs, or receipt of services individuals with communicable diseases or a related condition unless a determination is made by the Town Manager that such individual presents a direct threat or significant risk of substantial harm to the health or safety of the individual or others that cannot be eliminated or reduced by reasonable accommodation. It is the policy of the Town to consider the employment status or participation of an individual with a communicable disease on an individual case-by-case basis and in accordance with the ADA.

Section 7. Confidentiality of Medical Records

All information obtained by the Town regarding an applicant's or employee's disability, medical condition, request for reasonable accommodation, or workers' compensation shall be maintained on separate forms and in medical files which are separate from the regular personnel files. All medical files and records will be treated as confidential. Access to medical information shall be given for the following reasons only:

TOWN OF WEAVERVILLE AMERICANS WITH DISABILITIES COMPLIANCE POLICY

- a. To supervisors who may be told only about work restrictions for an applicant or employee;
- b. To first aid and safety officials where emergency treatment might be required;
- c. To government officials charged with enforcement of disability laws, including the ADA; and
- d. Human Resources staff and legal counsel on an as-needed basis.

Section 8. Reasonable Accommodation

It is the policy of the Town to provide reasonable modifications or adjustments to services, programs, or activities, to avoid discrimination on the basis of disability, unless the modification would result in a fundamental alteration or would impose an undue financial or administrative burden. The Town will make all reasonable efforts to provide appropriate services and aids so that people with disabilities receive effective communication.

The Town will make reasonable accommodations whenever necessary for all qualified employees or candidates for employment with disabilities (as defined by applicable law), provided that:

1. The individual is otherwise qualified to safely perform the essential job functions of the job, and
2. Such accommodations do not impose undue hardship on the Town.

Where a job or work assignment is subject to health or medical standards required for assignments or deployments in support of the military, this policy does not require employment of an employee or candidate who cannot satisfy those standards.

- A. **Requesting an Accommodation – Employee** – If an employee has a disability that requires an accommodation in order to perform the essential functions of his or her job, or otherwise enjoy the benefits and privileges of employments, he or she must initiate a request for accommodation by contacting his or her direct supervisor, the Human Resources Officer, or Town Manager, and identify an adjustment or change at work that is needed because of a disability.
- B. **Requesting an Accommodation – Candidate** – If a candidate for employment has a disability that requires an accommodation in order to apply for a job, he or she must initiate the request for accommodation by contacting Human Resources Officer or Town Manager and identifying an adjustment or change in the application or system that is needed because of a disability.
- C. **Participation in the Interactive Process** –
 - i. An employee seeking an accommodation under this policy will engage in an interactive dialogue (the “interactive process”) with his or her supervisory, department head, and Human Resources Officer, to

TOWN OF WEAVERVILLE AMERICANS WITH DISABILITIES COMPLIANCE POLICY

identify an accommodation that will allow the employee to perform the essential functions of the job effectively or engage in other benefits and privileges of employment that are enjoyed by similarly situated employees without disabilities.

- ii. If the Town is able to accommodate the request as a result of the interactive process, without the need for supporting medical documentation or other information, the employee does not need to proceed with any further steps outlined in this process.
 - iii. The ADA Coordinator has the responsibility to secure a final decision about questions regarding the implementation of an accommodation related to whether the medical condition is a qualifying disability under the ADA. In the event that additional medical information is needed to determine what accommodations may be necessary the ADA Coordinator will secure a release of medical information from the employee in order to obtain the medical information that is needed to make such a determination.
 - iv. The employee must cooperate with Human Resources in submitting necessary medical documentation and/or providing a release of medical information that permits HR to communicate with the employee's health care provider(s). The employee must return all forms and responsive information within 15 days of the request. Processing the request for accommodation may not proceed until all required forms have been completed and returned to Human Resources.
 - v. HR will review the completed request for accommodation forms received from the employee and/or the employee's health care provider. If the information provided is incomplete or requires further clarification, HR may request additional information from the employee or his or her health care provider.
- D. **Determination** – If, based on medical and other information provided by the employee and/or his or her health care provider, the employee is determined to be a qualified individual with a disability, the ADA Coordinator will notify the employee, supervisor, department head and Town Manager. The ADA Coordinator will work with the employee and the department head to identify and discuss reasonable accommodations that will enable the employee to perform the essential functions of the job or to participate in the same benefits and privileges of employment enjoyed by similarly situated employees without benefits. In instances where there is no reasonable accommodation that enables the employee to perform the essential functions of the job, including unpaid leave and assignment to a vacant position, the employee may be terminated.

TOWN OF WEAVERVILLE AMERICANS WITH DISABILITIES COMPLIANCE POLICY

- E. Responsibilities – Employees/Candidates** – Employees and candidates with a disability that interferes with their ability to apply for a job, perform their essential job functions or otherwise enjoy the benefits and privileges of employment that are available to other similarly situated employees without disabilities, and who desire an accommodation, must follow the process set forth above. The employee or candidate who requests an accommodation has the responsibility to submit all required documentation on a timely basis and to remain engaged in the interactive process with the Town while a determination is being made. It is the employee’s responsibility to work with his or her supervisor/department head, ADA Coordinator and qualified health care professional to review and complete all forms required. Any failure by the employee to supply the Town with all relevant and requested medical information or to otherwise meaningfully cooperate in the interactive process may result in the Town’s denial of an accommodation or delay in the process.
- F. Responsibilities – Management** – The Town Manager and all department heads are responsible for ensuring that all employees under their supervision are fully aware of the Town’s reasonable accommodation policy and equal employment opportunity and non-discrimination policy. When an employee requests an accommodation, supervisors and department heads must participate in the interactive process with the employee to determine if a reasonable accommodation can be made, with or without seeking additional information about the employee’s medical condition.
- If the ADA Coordinator determines that an employee’s medical condition is a qualifying disability under the ADA, supervisors and department heads must continue to work with the employee to identify existing reasonable accommodations that will enable the employee to perform the essential functions of his or her job.
- G. Responsibilities – ADA Coordinator** – The ADA Coordinator is responsible for determining whether an individual is entitled to an accommodation under the terms of this policy, assisting in the interactive process to identify reasonable accommodations as necessary, and informing employees of their rights and obligations pursuant to this policy. The ADA Coordinator is responsible for ensuring appropriate confidentiality of employees’ and candidates’ medical information, consistent with Town policy and state and federal law.

Section 9. Violations

Any employee found to be in violation of this policy will be subject to prompt disciplinary action under the Town’s Personnel Policy, up to and including dismissal.

Section 10. Adoption and Effective Date

This policy has been amended and restated by Town Council, is effective immediately, and shall be in full force and effect until such time as it is amended or repealed.

**TOWN OF WEAVERVILLE
AMERICANS WITH DISABILITIES
COMPLIANCE POLICY**

ADOPTED BY the Weaverville Town Council on the ____ day of April, 2020.

TOWN OF WEAVERVILLE

By: _____
Allan P. Root, Mayor

ATTESTED:

By: _____
Derek K. Huninghake, Town Clerk

TOWN OF WEAVERVILLE

GRIEVANCE POLICY AND PROCEDURES

Section 1. Policy

It is the policy of the Town to provide a just procedure for the presentation, consideration, and disposition of grievances of citizens or other non-employees. The purpose of this policy is to outline a grievance procedure and to assure the public that a response to their complaints and grievances will be prompt and fair.

Section 2. Definition

[ADA – Collectively the Americans with Disabilities Act and the Americans with Disabilities Act Amendment Act](#)

Grievance – A grievance is a claim or complaint of a citizen or customer of the Town, or member of the public against the Town or any of its officials or employees, including, but not limited to, claims or complaints alleging discrimination, harassment, retaliation, improper or unlawful activity, [Title VI civil rights discrimination](#), ADA accessibility issues, failure to provide services, or access to services, violations of Town policies, excessive or improper imposition of fees.

[Title VI – Title VI of the Civil Rights Act of 1964](#)

Section 3. Purposes of the Grievance Procedure

The purposes of the grievance procedure include, but are not limited to:

- (a) Providing the public with a procedure by which their complaints can be considered promptly and fairly;
- (b) Promoting better understanding of the Town's policies, practices, and procedures;
- (c) Increasing confidence that Town services are being delivered in accordance with established, fair, and uniform policies and procedures;
- (d) Encouraging conflicts to be resolved between the Town and the public in order to foster good relationships; and
- (e) Creating an environment free of continuing conflicts, disagreements, and negative feelings about the Town or its leaders in order to allow for better public relations and provision of municipal services.

Section 4. Procedure

When a member of the public has a grievance, the following successive steps are to be taken unless otherwise provided. The number of calendar days indicated for each step should be considered the maximum, unless otherwise provided, and every effort should be made to expedite the process. However, the time limits set forth may be extended by mutual consent. The last step initiated by the aggrieved person shall be considered to be the step at which the grievance is resolved. In all cases the Town Manager's decision shall be the final decision.

- (a) **Informal Resolution** – Prior to the submission of a formal grievance, the aggrieved person and Town employee should meet to discuss the problem and

TOWN OF WEAVERVILLE

GRIEVANCE POLICY AND PROCEDURES

seek to resolve it informally. Either the aggrieved person or Town employee may involve the respective Department Head as a resource to help resolve the grievance.

(b) Formal Resolution – If an informal resolution is not achieved then the following procedures shall be utilized with written documentation made at each step. For grievances involving ADA or Title VI civil rights issues, the respective coordinators will serve as the Department Head in the following steps (see Sections 5 and 6 below).

Step 1 – If no resolution to the grievance is reached informally, the aggrieved person who wishes to pursue a grievance shall present the grievance to the appropriate Department Head in writing. The Department Head shall respond to the grievance within 10 calendar days after receipt of the grievance. The Department Head should, and is encouraged to, consult with any employee of the Town in order to reach a correct, impartial, fair and equitable determination or decision concerning the grievance. Any employee consulted by the Department Head is required to cooperate to the fullest extent possible. The response shall explain the position of the Town and offer options for substantive resolution of the complaint.

Step 2 – If the grievance is not resolved to the satisfaction of the citizen at the end of Step 1, the aggrieved person may appeal, in writing, to the Town Manager within 10 calendar days after receipt of the response from Step 1. The Town Manager shall meet with the aggrieved person to discuss the complaint and possible resolutions. Within 10 calendar days of the meeting the Town Manager will respond in writing with a final resolution of the complaint.

The Town reserves the option, but not the requirement, to obtain a neutral outside party to provide mediation between the aggrieved person and the Town. Such parties might consist of attorneys trained in mediation, mediators, or other parties appropriate to the situation.

In all cases the Town Manager's decision shall be the final decision. The Town Manager shall notify the Mayor and Town Council of any impending legal action.

Section 5. Grievances Related to the Americans with Disabilities Act (ADA) or Title VI Civil Rights Discrimination

Complaints concerning discrimination on the basis of disability in the provision of services, activities, programs, or benefits by the Town should be sent to the ADA Coordinator who shall serve as the Department Head in the formal grievance steps set out herein if an informal resolution cannot be reached. Where appropriate, responses and resolutions shall be provided in a format that is accessible to the aggrieved person.

Complaints concerning discrimination on the basis of race, color, national origin, sex, age, or disability, in the provision of services, activities, programs, or benefits by the Town should be sent to the Civil Rights Coordinator who shall serve as the Department Head in the formal grievance steps set out herein if an informal resolution cannot be reached.

TOWN OF WEAVERVILLE GRIEVANCE POLICY AND PROCEDURES

Complaints involving the ADA Coordinator or the Civil Rights Coordinator can be made directly to the Town Manager.

Section 6. Contact Information for Submitting Grievances

The following contact information can be used to submit a grievance:

<u>GENERAL GRIEVANCES</u>	<u>ADA GRIEVANCES</u>	<u>TITLE VI CIVIL RIGHTS GRIEVANCES</u>
<u>Town Manager</u> <u>30 South Main Street</u> <u>Weaverville, NC 28787</u> <u>(828)645-7116</u> <u>coordinator@weavervillenc.org</u>	<u>ADA Coordinator</u> <u>30 South Main Street</u> <u>Weaverville, NC 28787</u> <u>(828)645-7116</u> <u>coordinator@weavervillenc.org</u>	<u>Civil Rights Coordinator</u> <u>30 South Main Street</u> <u>Weaverville, NC 28787</u> <u>(828)645-7116</u> <u>coordinator@weavervillenc.org</u>

Section 7. Adoption and Effective Date

This policy has been amended and restated by Town Council, is effective immediately, and shall be in full force and effect until such time as it is amended or repealed.

ADOPTED BY the Weaverville Town Council on the ____ day of April, 2020.

TOWN OF WEAVERVILLE

By: _____
Allan P. Root, Mayor

ATTESTED:

By: _____
Derek K. Huninghake, Town Clerk



TOWN OF WEAVERVILLE

APPENDIX B:

**"Make Weaverville Accessible
For All" Public Flyer**

ADA TRANSITION PLAN

MAKE WEAVERVILLE ACCESSIBLE FOR ALL



TAKE PART IN THE ADA TRANSITION PLAN PROCESS

In an effort to make the Town of Weaverville facilities and programs accessible to all, the Town has embarked on a comprehensive evaluation and Transition Plan process. The Plan seeks to identify barriers which impede access to Town facilities that are open to the public and to ensure compliance with the Americans with Disabilities Act (ADA) Title II requirements.

A key element of this project is to engage the public and gather public comment on accessibility issues within our community.

HOW TO PROVIDE FEEDBACK

1

WRITTEN COMMENTS – Submit written comments by May 31

Email to: compliance@weavervillenc.org

Dropbox at: Town Hall (30 South Main St.) at front door and back parking lot

Mail to: ADA Coordinator
Town of Weaverville
PO Box 338
Weaverville, NC, 28787

2

TELEPHONE CONFERENCE – Call (828)645-7116 to schedule a telephone conference with the ADA Coordinator during the month of May

3

PUBLIC INPUT SESSIONS – Join us at a drop-in meeting or remote electronic meeting
Drop-In on May 14 from 5 – 6 pm in the Community Room, 30 South Main St, Weaverville

Zoom Meetings: May 14 at 3 pm – Meeting ID 884 5534 0950

Join by computer: <https://us02web.zoom.us/j/88455340950>

Join by phone: (253)215-8782 or (301)715-8592

May 27 at 10 am – Meeting ID 842 5567 3059

Join by computer: <https://us02web.zoom.us/j/84255673059>

Join by phone: (253)215-8782 or (301)715-8592

For more information, please contact Jennifer Jackson, Town ADA Coordinator
jjackson@weavervillenc.org or (828)645-7116



TOWN OF WEAVERVILLE

APPENDIX C:

ADA Checklists for
Existing Facilities

ADA TRANSITION PLAN



TOWN OF WEAVERVILLE

APPENDIX C.1:

Town Hall

ADA TRANSITION PLAN

ADA Checklist for Existing Facilities

Priority 1 – Approach & Entrance

Based on the 2010 ADA Standards for Accessible Design

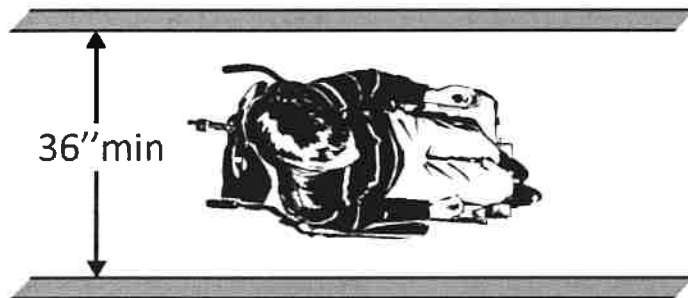

Project ADA TRANSITION PLAN

Building TOWN HALL

Location WEAVERVILLE N.C.

Date 4-20-2020

Surveyors AVAN F. WALKER

Contact Information JENNIFER JACKSON

An accessible route from site arrival points and an accessible entrance should be provided for everyone.



Institute for Human Centered Design
www.HumanCenteredDesign.org
Copyright © 2016



ADA National Network
Questions on the ADA 800-949-4232 voice/tty
www.ADAchecklist.org

This checklist was produced by the New England ADA Center, a project of the Institute for Human Centered Design and a member of the ADA National Network. This checklist was developed under a grant from the Department of Education, NIDRR grant number H133A060092-09A. However the contents do not necessarily represent the policy of the Department of Education, and you should not assume endorsement by the Federal Government.

Questions or comments on the checklist contact the New England ADA Center at 617-695-0085 voice/tty or ADAinfo@NewEnglandADA.org

For the full set of checklists, including the checklists for recreation facilities visit www.ADAchecklist.org.

Copyright © 2016 ADA Checklist for Existing Materials. You can freely reproduce and distribute this content. Include proper attribution. But you must get permission before using this content as a fee-based product.

Priority 1 – Approach & Entrance		Comments	Possible Solutions												
<p>1.1 Is there at least one route from site arrival points (parking, passenger loading zones, public sidewalks and public transportation stops) that does not require the use of stairs? [See 2010 ADA Standards for Accessible Design – 206.2.1]</p>	<p><input checked="" type="checkbox"/> Yes <input type="checkbox"/> No</p> <p>If yes, location of route:</p>	<p>Photo #:</p>	<ul style="list-style-type: none"> • Add a ramp • Regrade to 1:20 maximum slope • Add a lift if site constraints prevent other solutions 												
<p>Parking Accessible parking spaces should be identified by size, access aisle and signage.</p>															
<p>1.2 If parking is provided for the public, are an adequate number of accessible spaces provided? [208.2]</p>	<p><input checked="" type="checkbox"/> Yes <input type="checkbox"/> No</p> <p>Total #: 29</p> <p>Accessible #: 2</p>	<table border="1"> <thead> <tr> <th>Total Spaces</th> <th>Accessible Spaces</th> </tr> </thead> <tbody> <tr> <td>1 - 25</td> <td>1</td> </tr> <tr> <td>26 - 50</td> <td>2</td> </tr> <tr> <td>51 - 75</td> <td>3</td> </tr> <tr> <td>76 - 100</td> <td>4</td> </tr> <tr> <td colspan="2">100+ see 2010 Standards 208.2</td> </tr> </tbody> </table> <p>Photo #:</p>	Total Spaces	Accessible Spaces	1 - 25	1	26 - 50	2	51 - 75	3	76 - 100	4	100+ see 2010 Standards 208.2		<ul style="list-style-type: none"> • Reconfigure by repainting lines • •
Total Spaces	Accessible Spaces														
1 - 25	1														
26 - 50	2														
51 - 75	3														
76 - 100	4														
100+ see 2010 Standards 208.2															
<p>1.3 Of the accessible spaces, is at least one a van accessible space?*[208.2.4]</p>	<p><input type="checkbox"/> Yes <input checked="" type="checkbox"/> No</p>	<p>*For every 6 or fraction of 6 parking spaces required by the table above, at least 1 should be a van accessible space.</p> <p>Photo #:</p>	<ul style="list-style-type: none"> • If constructed before 3/15/2012, parking is compliant if at least 1 in every 8 accessible spaces is van accessible • Reconfigure by repainting lines 												

ADA Checklist for Existing Facilities

Priority 1 – Approach & Entrance

1.4 Are accessible spaces at least 8 feet wide with an access aisle at least 5 feet wide?
[502.2, 502.3]

Note: Two spaces may share an access aisle. Check state/local requirements; some specify that each space have its own aisle.

Yes No

Measurement:

8'

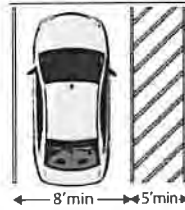

NO STRIPES ALONG STREET

Photo #:

- Reconfigure by repainting lines
-
-

1.5 Is the van accessible space:

At least 11 feet wide with an access aisle at least 5 feet wide?

Or

At least 8 feet wide with an access aisle at least 8 feet wide?

[502.2]

Yes No

Measurement:

N/A

Yes No

Measurement:

N/A

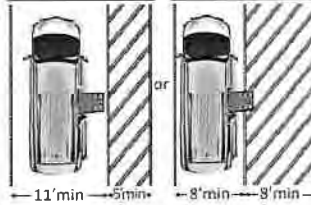

Photo #:

- Reconfigure to provide van-accessible space(s)
-
-

1.6 Is at least 98 inches of vertical clearance provided for the van accessible space?
[502.5]

N/A

Yes No

Measurement:

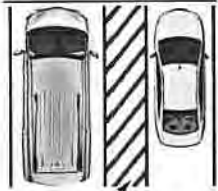

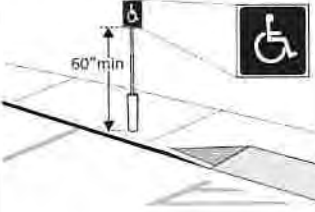



Photo #:

- Reconfigure to provide van-accessible space(s)
-
-

ADA Checklist for Existing Facilities

Priority 1 – Approach & Entrance

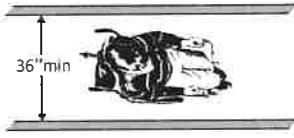

<p>1.7 Are the access aisles marked so as to discourage parking in them? [502.3.3]</p> <p>Note: The marking method and color may be addressed by state/local requirements.</p>	<p><input checked="" type="checkbox"/> Yes <input type="checkbox"/> No</p>		<p>Photo #:</p>	<ul style="list-style-type: none"> • Mark access aisles • •
<p>1.8 Is the slope of the accessible parking spaces and access aisles no steeper than 1:48 in all directions? [502.4]</p>	<p><input checked="" type="checkbox"/> Yes <input type="checkbox"/> No</p> <p>Measurement:</p>		<p>Photo #:</p>	<ul style="list-style-type: none"> • Regrade surface • •
<p>1.9 Do the access aisles adjoin an accessible route? [502.3]</p>	<p><input type="checkbox"/> Yes <input checked="" type="checkbox"/> No</p>		<p>Photo #:</p>	<ul style="list-style-type: none"> • Create accessible route • Relocate accessible space •
<p>1.10 Are accessible spaces identified with a sign that includes the International Symbol of Accessibility? Is the bottom of the sign at least 60 inches above the ground? [502.6]</p> <p>Note: The International Symbol of Accessibility is not required on the ground.</p>	<p><input type="checkbox"/> Yes <input type="checkbox"/> No</p> <p><input type="checkbox"/> Yes <input type="checkbox"/> No</p> <p>Measurement:</p>		<p>Photo #:</p>	<ul style="list-style-type: none"> • Install signs • •

<p>1.11 Are there signs reading “van accessible” at van accessible spaces? [502.6]</p>	<p><input type="checkbox"/> Yes <input type="checkbox"/> No</p>		<p>Photo #:</p>	<ul style="list-style-type: none"> • Install signs •
<p>1.12 Of the total parking spaces, are the accessible spaces located on the closest accessible route to the accessible entrance(s)? [208.3.1]</p> <p>Note: If parking serves multiple entrances, accessible parking should be dispersed.</p>	<p><input type="checkbox"/> Yes <input type="checkbox"/> No</p>	<p>Photo #:</p>	<p>Photo #:</p>	<ul style="list-style-type: none"> • Reconfigure spaces •
<p>Exterior Accessible Route</p>				
<p>1.13 Is the route stable, firm and slip-resistant? [302.1]</p>	<p><input checked="" type="checkbox"/> Yes <input type="checkbox"/> No</p>	<p>Photo #:</p>	<p>Photo #:</p>	<ul style="list-style-type: none"> • Repair uneven paving • Fill small bumps and breaks with patches • Replace gravel with asphalt or other surface
<p>1.14 Is the route at least 36 inches wide? [403.5.1]</p>	<p><input type="checkbox"/> Yes <input type="checkbox"/> No</p> <p>Measurement:</p>		<p>Photo #:</p>	<ul style="list-style-type: none"> • Change or move landscaping, furnishings or other items • Widen route •

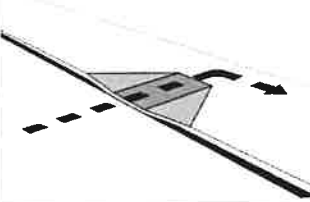
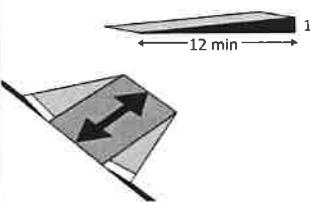
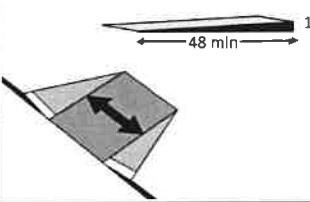
<p>Note: The accessible route can narrow to 32 inches min. for a max. of 24 inches. These narrower portions of the route must be at least 48 inches from each other.</p>			<p>Photo #:</p>
<p>1.15 If the route is greater than 200 feet in length and less than 60 inches wide, is there a passing space no less than 60 x 60 inches? [403.5.3]</p>	<p><input type="checkbox"/> Yes <input type="checkbox"/> No</p> <p>Measurement:</p>		<p>Photo #:</p> <ul style="list-style-type: none"> • Widen route for passing space • •
<p>1.16 If there are grates or openings on the route, are the openings no larger than 1/2 inches?</p> <p>Is the long dimension perpendicular to the dominant direction of travel? [302.3]</p>	<p><input type="checkbox"/> Yes <input type="checkbox"/> No</p> <p>Measurement:</p> <p><input type="checkbox"/> Yes <input type="checkbox"/> No</p>		<p>Photo #:</p> <ul style="list-style-type: none"> • Replace or move grate • •
<p>1.17 Is the running slope no steeper than 1:20, i.e. for every inch of height change there are at least 20 inches of route run? [403.3]</p> <p>Note: If the running slope is steeper than 1:20, treat as a ramp and add features such as edge protection and handrails.</p>	<p><input type="checkbox"/> Yes <input type="checkbox"/> No</p> <p>Measurement:</p>		<p>Photo #:</p> <ul style="list-style-type: none"> • Regrade to 1:20 max. • •

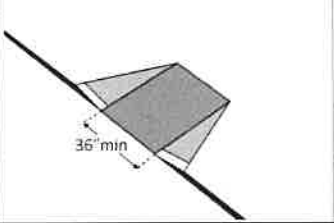
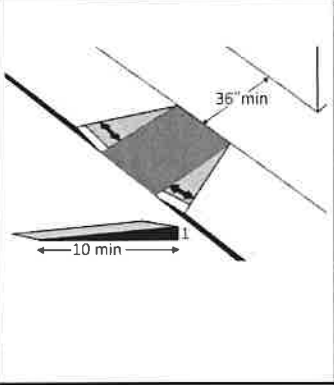
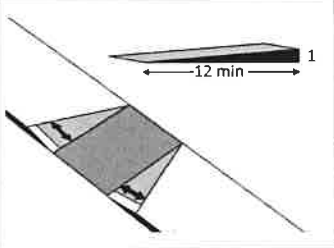
<p>1.18 Is the cross slope no steeper than 1:48? [403.3]</p>	<p><input type="checkbox"/> Yes <input type="checkbox"/> No</p> <p>Measurement:</p>		<p>Photo #:</p>	<ul style="list-style-type: none"> • Regrade to 1:48 max. • •
<p>Curb Ramps</p>				
<p>1.19 If the accessible route crosses a curb, is there a curb ramp? [402.2]</p>	<p><input type="checkbox"/> Yes <input type="checkbox"/> No</p>		<p>Photo #:</p>	<ul style="list-style-type: none"> • Install curb ramp • •
<p>1.20 Is the running slope of the curb ramp no steeper than 1:12, i.e. for every inch of height change there are at least 12 inches of curb ramp run? [406.1, 405.2]</p>	<p><input type="checkbox"/> Yes <input type="checkbox"/> No</p> <p>Measurement:</p>		<p>Photo #:</p>	<ul style="list-style-type: none"> • Regrade curb ramp • •
<p>1.21 Is the cross slope of the curb ramp, excluding flares, no steeper than 1:48? [406.1, 405.3]</p>	<p><input type="checkbox"/> Yes <input type="checkbox"/> No</p> <p>Measurement:</p>		<p>Photo #:</p>	<ul style="list-style-type: none"> • Regrade curb ramp • •

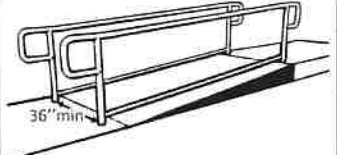

<p>1.22 Is the curb ramp, excluding flares, at least 36 inches wide? [406.1, 405.5]</p>	<p><input type="checkbox"/> Yes <input type="checkbox"/> No</p> <p>Measurement:</p>	 <p>A perspective diagram of a curb ramp. A shaded rectangular area represents the flare, extending 36 inches from the edge of the ramp. A dimension line below the flare is labeled "36" min".</p>	<p>Photo #:</p>	<ul style="list-style-type: none"> • Widen curb ramp • •
<p>1.23 At the top of the curb ramp is there a level landing (slope no steeper than 1:48 in all directions) that is at least 36 inches long and at least as wide as the curb ramp? [406.4]</p> <p>If there are curb ramp flares, are the slopes of the flares no steeper than 1:10, i.e. for every inch of height change there are at least 10 inches of flare run? [406.3]</p>	<p><input type="checkbox"/> Yes <input type="checkbox"/> No</p> <p>Measurement:</p> <p><input type="checkbox"/> Yes <input type="checkbox"/> No</p> <p>Measurement:</p>	 <p>Two diagrams. The top one shows a perspective view of a curb ramp with a level landing at the top. A dimension line across the landing is labeled "36" min". The bottom one shows a side view of a flare. A dimension line along the horizontal run of the flare is labeled "10 min".</p>	<p>Photo #:</p>	<ul style="list-style-type: none"> • Reconfigure • Add ramp flares •
<p>1.24 If the landing at the top is less than 36 inches long, are there curb ramp flares?</p> <p>Are the slopes of the flares no greater than 1:12, i.e. for every inch of height change there are at least 12 inches of flare run? [406.4]</p>	<p><input type="checkbox"/> Yes <input type="checkbox"/> No</p> <p><input type="checkbox"/> Yes <input type="checkbox"/> No</p> <p>Measurement:</p>	 <p>Two diagrams. The top one shows a side view of a flare. A dimension line along the horizontal run of the flare is labeled "12 min". The bottom one shows a perspective view of a curb ramp with a flare at the top.</p>	<p>Photo #:</p>	<ul style="list-style-type: none"> • Add ramp flares • Regrade flares •

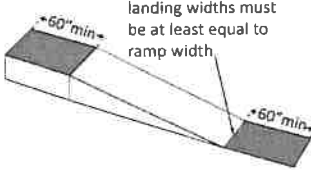
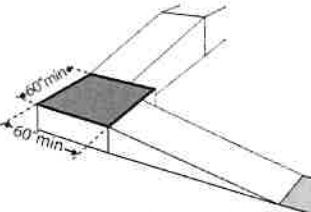
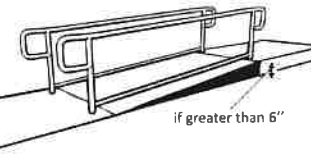
Ramps If any portion of the accessible route is steeper than 1:20, it should be treated as a ramp.				
<p>1.25 If there is a ramp is it at least 36 inches wide? [405.5]</p> <p>Note: If there are handrails, measure between the handrails.</p>	<p><input type="checkbox"/> Yes <input type="checkbox"/> No</p> <p>Measurement:</p>		<p>Photo #:</p>	<ul style="list-style-type: none"> • Alter ramp • •
<p>1.26 Is the surface stable, firm and slip resistant? [405.4]</p>	<p><input type="checkbox"/> Yes <input type="checkbox"/> No</p>		<p>Photo #:</p>	<ul style="list-style-type: none"> • Resurface ramp • •
<p>1.27 For each section of the ramp, is the running slope no greater than 1:12, i.e. for every inch of height change there are at least 12 inches of ramp run? [405.2]</p> <p>Note: Rises no greater than 3 inches with a slope no steeper than 1:8 and rises no greater than 6 inches with a slope no steeper than 1:10 are permitted when such slopes are necessary due to space limitations.</p>	<p><input type="checkbox"/> Yes <input type="checkbox"/> No</p> <p>Measurement:</p>		<p>Photo #:</p>	<ul style="list-style-type: none"> • Relocate ramp • Lengthen ramp to decrease slope •

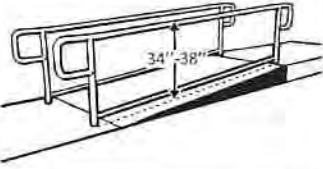
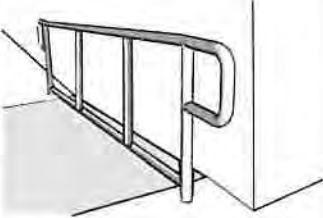
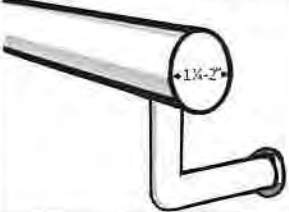
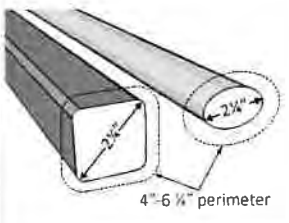
<p>1.28 Is there a level landing that is at least 60 inches long and at least as wide as the ramp:</p> <p>At the top of the ramp? <input type="checkbox"/> Yes <input type="checkbox"/> No</p> <p>Measurement:</p> <p>At the bottom of the ramp? <input type="checkbox"/> Yes <input type="checkbox"/> No</p> <p>[405.7.2, 405.7.3]</p>	<p><input type="checkbox"/> Yes <input type="checkbox"/> No</p> <p>Measurement:</p> <p><input type="checkbox"/> Yes <input type="checkbox"/> No</p> <p>Measurement:</p>		<p>Photo #:</p>	<ul style="list-style-type: none"> • Alter ramp • Relocate ramp •
<p>1.29 Is there a level landing where the ramp changes direction that is at least 60 x 60 inches? [405.7.4]</p>	<p><input type="checkbox"/> Yes <input type="checkbox"/> No</p> <p>Measurement:</p>		<p>Photo #:</p>	<ul style="list-style-type: none"> • Alter ramp • Increase landing size •
<p>1.30 If the ramp has a rise higher than 6 inches, are there handrails on both sides? [405.8]</p> <p>Note: Curb ramps are not required to have handrails.</p>	<p><input type="checkbox"/> Yes <input type="checkbox"/> No</p> <p>Measurement:</p>		<p>Photo #:</p>	<ul style="list-style-type: none"> • Add handrails • •

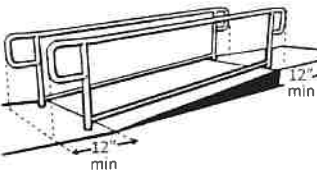
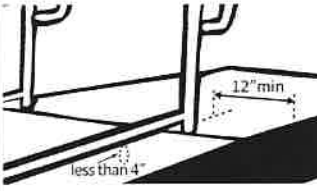
<p>1.31 Is the top of the handrail gripping surface no less than 34 inches and no greater than 38 inches above the ramp surface? [505.4]</p>	<p><input type="checkbox"/> Yes <input type="checkbox"/> No Measurement:</p>		<p>Photo #:</p>	<ul style="list-style-type: none"> • Reconfigure or replace handrails • Adjust handrail height •
<p>1.32 Is the handrail gripping surface continuous and not obstructed along the top or sides? [505.3]</p> <p>If there are obstructions, is the bottom of the gripping surface obstructed no greater than 20%? [505.6]</p>	<p><input type="checkbox"/> Yes <input type="checkbox"/> No Measurement:</p> <p><input type="checkbox"/> Yes <input type="checkbox"/> No Measurement:</p>		<p>Photo #:</p>	<ul style="list-style-type: none"> • Reconfigure or replace handrails • •
<p>1.33 If the handrail gripping surface is circular, is it no less than 1 1/4 inches and no greater than 2 inches in diameter? [505.7.1]</p>	<p><input type="checkbox"/> Yes <input type="checkbox"/> No Measurement:</p>		<p>Photo #:</p>	<ul style="list-style-type: none"> • Replace handrails • •
<p>1.34 If the handrail gripping surface is non-circular:</p> <p>Is the perimeter no less than 4 inches and no greater than 6 1/4 inches?</p>	<p><input type="checkbox"/> Yes <input type="checkbox"/> No Measurement:</p> <p><input type="checkbox"/> Yes <input type="checkbox"/> No Measurement:</p>		<p>Photo #:</p>	<ul style="list-style-type: none"> • Replace handrails • •

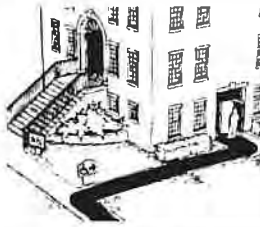

<p>Is the cross section no greater than 2¼ inches? [505.7.2]</p>	<p><input type="checkbox"/> Yes <input type="checkbox"/> No Measurement:</p>		<p>Photo #:</p>	
<p>1.35 Does the handrail:</p> <p>Extend at least 12 inches horizontally beyond the top and bottom of the ramp?</p> <p>Return to a wall, guard, or landing surface? [505.10.1]</p> <p>Note: If a 12 inch extension would be a hazard (in circulation path) it is not required.</p>	<p><input type="checkbox"/> Yes <input type="checkbox"/> No Measurement:</p> <p><input type="checkbox"/> Yes <input type="checkbox"/> No Measurement:</p>		<p>Photo #:</p>	<ul style="list-style-type: none"> • Alter handrails • •
<p>1.36 To prevent wheelchair casters and crutch tips from falling off:</p> <p>Does the surface of the ramp extend at least 12 inches beyond the inside face of the handrail? Or Is there a curb or barrier that prevents the passage of a 4-inch diameter sphere? [405.9.1, 405.9.2]</p>	<p><input type="checkbox"/> Yes <input type="checkbox"/> No Measurement:</p> <p><input type="checkbox"/> Yes <input type="checkbox"/> No Measurement:</p>		<p>Photo #:</p>	<ul style="list-style-type: none"> • Add curb • Add barrier • Extend ramp width •

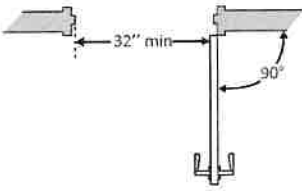
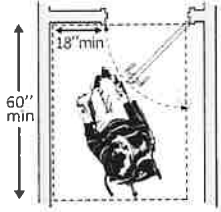
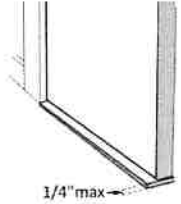
Entrance				
<p>1.37 Is the main entrance accessible?</p>	<p><input type="checkbox"/> Yes <input type="checkbox"/> No</p>		<p>Photo #:</p>	<ul style="list-style-type: none"> • Redesign to make it accessible • •
<p>1.38 If the main entrance is not accessible, is there an alternative accessible entrance?</p> <p>Can the alternative accessible entrance be used independently and during the same hours as the main entrance?</p>	<p><input type="checkbox"/> Yes <input type="checkbox"/> No</p> <p><input type="checkbox"/> Yes <input type="checkbox"/> No</p>		<p>Photo #:</p>	<ul style="list-style-type: none"> • Designate an entrance and make it accessible • Ensure that accessible entrance can be used independently and during the same hours as the main entrance •
<p>1.39 Do all inaccessible entrances have signs indicating the location of the nearest accessible entrance? [216.6]</p>	<p><input type="checkbox"/> Yes <input type="checkbox"/> No</p>		<p>Photo #:</p>	<ul style="list-style-type: none"> • Install signs • Install signs on route before people get to inaccessible entrances so that people do not have to turn around and retrace route •
<p>1.40 If not all entrances are accessible, is there a sign at the accessible entrance with the International Symbol of Accessibility? [216.6]</p>	<p><input type="checkbox"/> Yes <input type="checkbox"/> No</p>		<p>Photo #:</p>	<ul style="list-style-type: none"> • Install sign • •

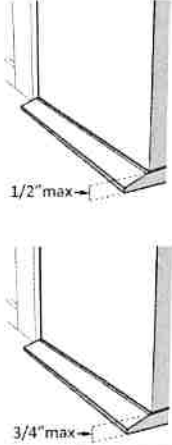
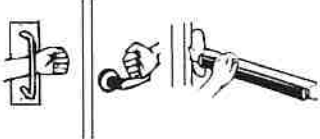
<p>1.41 Is the clear opening width of the accessible entrance door at least 32 inches, between the face of the door and the stop, when the door is open 90 degrees? [404.2.3]</p>	<p><input type="checkbox"/> Yes <input type="checkbox"/> No Measurement:</p>		<p>Photo #:</p>	<ul style="list-style-type: none"> • Alter door • Install offset hinges •
<p>1.42 If there is a front approach to the pull side of the door, is there at least 18 inches of maneuvering clearance beyond the latch side plus at least 60 inches clear depth? Note: See 2010 Standards 404.2.4 for maneuvering clearance requirements on the push side of the door and side approaches to the pull side of the door</p> <p>On both sides of the door, is the ground or floor surface of the maneuvering clearance level (no steeper than 1:48)? [404.2.4]</p>	<p><input type="checkbox"/> Yes <input type="checkbox"/> No Measurement:</p> <p><input type="checkbox"/> Yes <input type="checkbox"/> No Measurement:</p>		<p>Photo #:</p>	<ul style="list-style-type: none"> • Remove obstructions • Reconfigure walls • Add automatic door opener
<p>1.43 If the threshold is vertical is it no more than 1/4 inch high? Or No more than 1/2 inch high with the top 1/4 inch beveled no steeper than 1:2, if the threshold was installed on or</p>	<p><input type="checkbox"/> Yes <input type="checkbox"/> No Measurement:</p> <p><input type="checkbox"/> Yes <input type="checkbox"/> No Measurement:</p>		<p>Photo #:</p>	<ul style="list-style-type: none"> • Remove or replace threshold • •

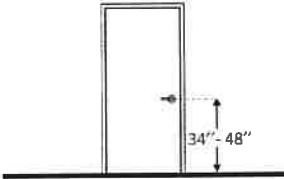
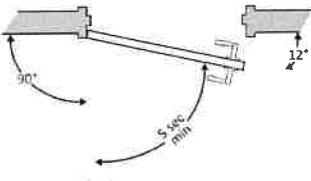
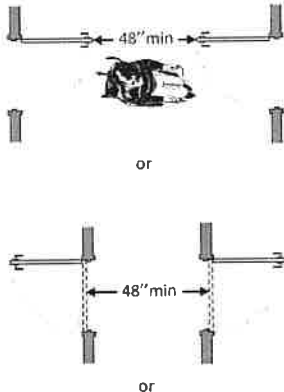
<p>after the 1991 ADA Standards went into effect (1/26/93)?</p> <p>Or</p> <p>No more than 3/8 inch high with the top 1/2 inch beveled no steeper than 1:2, if the threshold was installed before the 1991 ADA Standards went into effect (1/26/93)? [404.2.5, 303.2]</p> <p>Note: The first 1/4 inch of the 3/8 or 1/2 inch threshold may be vertical; the rest must be beveled.</p>	<p><input type="checkbox"/> Yes <input type="checkbox"/> No</p> <p>Measurement:</p>		<p>Photo #:</p>	
<p>1.44 Is the door equipped with hardware that is operable with one hand and does not require tight grasping, pinching or twisting of the wrist?</p> <p>Door handle?</p> <p>Lock (if provided)? [404.2.7]</p>	<p><input type="checkbox"/> Yes <input type="checkbox"/> No</p> <p><input type="checkbox"/> Yes <input type="checkbox"/> No</p> <p><input type="checkbox"/> Yes <input type="checkbox"/> No</p>		<p>Photo #:</p>	<ul style="list-style-type: none"> • Replace inaccessible knob with lever, loop or push hardware • Add automatic door opener •

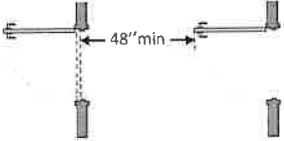
<p>1.45 Are the operable parts of the door hardware no less than 34 inches and no greater than 48 inches above the floor or ground surface? [404.2.7]</p>	<p><input type="checkbox"/> Yes <input type="checkbox"/> No Measurement:</p>		<p>Photo #:</p>	<ul style="list-style-type: none"> • Change hardware height • •
<p>1.46 If the door has a closer, does it take at least 5 seconds to close from an open position of 90 degrees to a position of 12 degrees from the latch? [404.2.8]</p>	<p><input type="checkbox"/> Yes <input type="checkbox"/> No Measurement:</p>		<p>Photo #:</p>	<ul style="list-style-type: none"> • Adjust closer • •
<p>1.47 If there are two doors in a series, e.g. vestibule, is the distance between the doors at least 48 inches plus the width of the doors when swinging into the space? [404.2.6]</p>	<p><input type="checkbox"/> Yes <input type="checkbox"/> No Measurement:</p>		<p>Photo #:</p>	<ul style="list-style-type: none"> • Remove inner door • Change door swing •

			<p>Photo #:</p>	
<p>1.48 If provided at the building entrance, are carpets or mats no higher than 1/4 inch thick? [302.2]</p>	<p><input type="checkbox"/> Yes <input type="checkbox"/> No</p> <p>Measurement:</p>		<p>Photo #:</p>	<ul style="list-style-type: none"> • Replace or remove mats • •
<p>1.49 Are edges of carpets or mats securely attached to minimize tripping hazards? [302.2]</p>	<p><input type="checkbox"/> Yes <input type="checkbox"/> No</p>		<p>Photo #:</p>	<ul style="list-style-type: none"> • Secure carpeting or mats at edges • •
	<p><input type="checkbox"/> Yes <input type="checkbox"/> No</p>		<p>Photo #:</p>	<ul style="list-style-type: none"> • • •
	<p><input type="checkbox"/> Yes <input type="checkbox"/> No</p>		<p>Photo #:</p>	<ul style="list-style-type: none"> • • •

ADA Checklist for Existing Facilities

Priority 2 – Access to Goods & Services

Based on the 2010 ADA Standards for Accessible Design

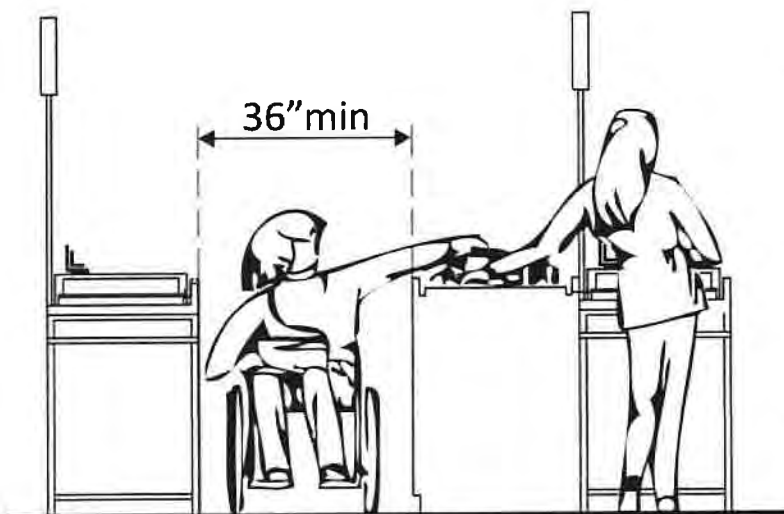

Project ADA TRANSITION

Building TOWN HALL

Location WEAVERVILLE N.C.

Date _____

Surveyors _____

Contact Information _____

The layout of the building should allow people with disabilities to obtain goods and services and to participate in activities without assistance.



Institute for Human Centered Design
www.HumanCenteredDesign.org
Copyright © 2016



ADA National Network
Questions on the ADA 800-949-4232 voice/tty
www.ADAchecklist.org

5942 TO KITCHEN
SIGN

This checklist was produced by the New England ADA Center, a project of the Institute for Human Centered Design and a member of the ADA National Network. This checklist was developed under a grant from the Department of Education, NIDRR grant number H133A060092-09A. However the contents do not necessarily represent the policy of the Department of Education, and you should not assume endorsement by the Federal Government.

Questions or comments on the checklist contact the New England ADA Center at 617-695-0085 voice/tty or ADAinfo@NewEnglandADA.org

For the full set of checklists, including the checklists for recreation facilities visit www.ADAchecklist.org.

Copyright © 2016 ADA Checklist for Existing Materials. You can freely reproduce and distribute this content. Include proper attribution. But you must get permission before using this content as a fee-based product.

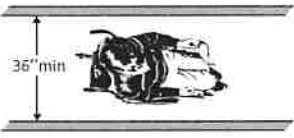
Priority 2 – Access to Goods & Services		Comments	Possible Solutions
<p>2.1 Does the accessible entrance provide direct access to the main floor, lobby and elevator? [See 2010 ADA Standards for Accessible Design – 206.4]</p> <p><input type="checkbox"/> Yes <input type="checkbox"/> No</p>		Photo #:	<ul style="list-style-type: none"> • Create accessible route • •
Interior Accessible Route			
<p>2.2 Are all public spaces on at least one accessible route? [206.2.4]</p> <p><input type="checkbox"/> Yes <input type="checkbox"/> No</p>		Photo #:	<ul style="list-style-type: none"> • Create accessible route • •
<p>2.3 Is the route stable, firm and slip-resistant? [40.2, 302.1]</p> <p><input type="checkbox"/> Yes <input type="checkbox"/> No</p>		Photo #:	<ul style="list-style-type: none"> • Repair uneven surfaces • •
<p>2.4 Is the route at least 36 inches wide? [403.5.1]</p> <p>Note: The accessible route can narrow to 32 inches min. for a max. of 24 inches. These narrower portions of the route must be at least 48 inches from each other.</p>	<p>Measurement:</p> 		<ul style="list-style-type: none"> • Widen route • •

			<p>Photo #:</p>	
<p>2.5 If the route is greater than 200 feet in length and less than 60 inches wide, is there a passing space no less than 60 x 60 inches? [403.5.3]</p>	<p><input type="checkbox"/> Yes <input type="checkbox"/> No Measurement:</p>		<p>Photo #:</p>	<ul style="list-style-type: none"> • Widen route for passing space • •
<p>2.6 Is the running slope no steeper than 1:20, i.e. for every inch of height change there are at least 20 inches of route run? [403.3]</p> <p>Note: If the running slope is steeper than 1:20, treat as a ramp and add features such as edge protection and handrails.</p>	<p><input type="checkbox"/> Yes <input type="checkbox"/> No Measurement:</p>		<p>Photo #:</p>	<ul style="list-style-type: none"> • Regrade • •
<p>2.7 Is the cross slope no steeper than 1:48? [403.3]</p>	<p><input type="checkbox"/> Yes <input type="checkbox"/> No Measurement:</p>		<p>Photo #:</p>	<ul style="list-style-type: none"> • Regrade • •

2.8 Do all objects on circulation paths through public areas, e.g. fire extinguishers, drinking fountains, signs, etc., protrude no more than 4 inches into the path?

Yes No

Measurement:



Or

Or

If an object protrudes more than 4 inches, is the bottom leading edge at 27 inches or lower above the floor? [307.2]

Yes No

Measurement:



Or

Or

Is the bottom leading edge at 80 inches or higher above the floor? [307.4]

Yes No

Measurement:



Photo #:

- Remove object
- Add tactile warning such as permanent planter or partial walls
-

2.9 Are there elevators or platform lifts to all public stories?

Yes No

Note: Vertical access is not required in new construction or alterations if a facility is less than three stories or has less than 3,000 square feet per story, unless the facility is a shopping center, shopping mall,

- Install if necessary
- Offer goods and services on an accessible story
-

professional office of a health care provider, transportation terminal, state facility or local government facility

Photo #:

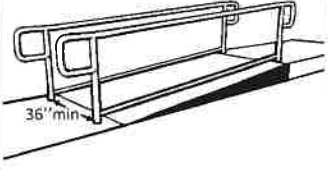
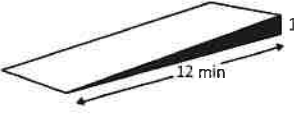
Ramps				
<p>2.10 If there is a ramp, is it at least 36 inches wide? [405.5]</p> <p>Note: If there are handrails, measure between the handrails.</p>	<p><input type="checkbox"/> Yes <input type="checkbox"/> No</p> <p>Measurement:</p>		<p>Photo #:</p>	<ul style="list-style-type: none"> • Alter ramp • •
<p>2.11 Is the surface stable, firm and slip resistant? [405.4]</p>	<p><input type="checkbox"/> Yes <input type="checkbox"/> No</p>		<p>Photo #:</p>	<ul style="list-style-type: none"> • Resurface ramp • •
<p>2.12 For each section of the ramp, is the running slope no greater than 1:12, i.e. for every inch of height change there are at least 12 inches of ramp run? [405.2]</p> <p>Note: Rises no greater than 3 inches with a slope no steeper than 1:8 and rises no greater</p>	<p><input type="checkbox"/> Yes <input type="checkbox"/> No</p> <p>Measurement:</p>		<p>Photo #:</p>	<ul style="list-style-type: none"> • Lengthen ramp to decrease slope • Relocate ramp •

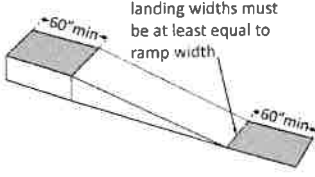
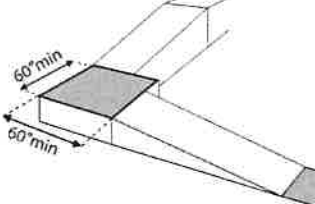
<p>than 6 inches with a slope no steeper than 1:10 are permitted when due to space limitations.</p>			<p>Photo #:</p>	
<p>2.13 Is there a level landing that is at least 60 inches long and at least as wide as the ramp:</p> <p>At the top of the ramp?</p> <p>At the bottom of the ramp? [405.7.2, 405.7.3]</p>	<p><input type="checkbox"/> Yes <input type="checkbox"/> No</p> <p>Measurement:</p> <p><input type="checkbox"/> Yes <input type="checkbox"/> No</p> <p>Measurement:</p>		<p>Photo #:</p>	<ul style="list-style-type: none"> • Alter ramp • Relocate ramp •
<p>2.14 Is there a level landing where the ramp changes direction that is at least 60 x 60 inches? [405.7.4]</p>	<p><input type="checkbox"/> Yes <input type="checkbox"/> No</p> <p>Measurement:</p>		<p>Photo #:</p>	<ul style="list-style-type: none"> • Increase landing size • •

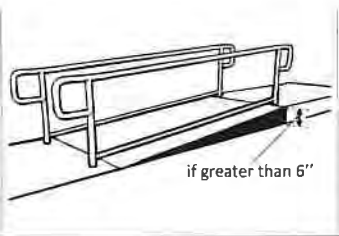
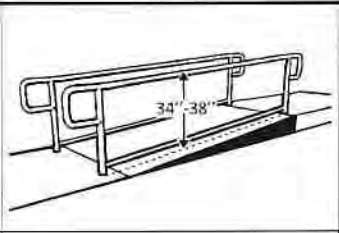
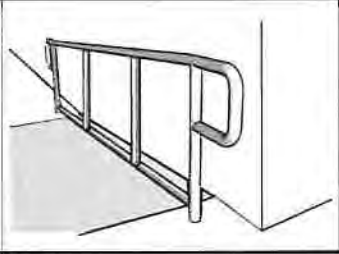
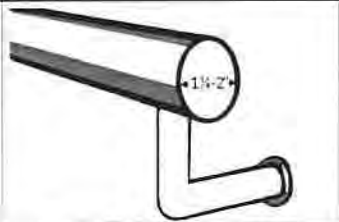
<p>2.15 If the ramp has a rise higher than 6 inches are there handrails on both sides? [405.8]</p>	<p><input type="checkbox"/> Yes <input type="checkbox"/> No Measurement:</p>		<p>Photo #:</p> <ul style="list-style-type: none"> • Add handrails • •
<p>2.16 Is the top of the handrail gripping surface no less than 34 inches and no greater than 38 inches above the ramp surface? [505.4]</p>	<p><input type="checkbox"/> Yes <input type="checkbox"/> No Measurement:</p>		<p>Photo #:</p> <ul style="list-style-type: none"> • Adjust handrail height • •
<p>2.17 Is the handrail gripping surface continuous and not obstructed along the top or sides? [505.3]</p> <p>If there are obstructions, is the bottom of the gripping surface obstructed no more than 20%? [505.6]</p>	<p><input type="checkbox"/> Yes <input type="checkbox"/> No <input type="checkbox"/> Yes <input type="checkbox"/> No Measurement:</p>		<p>Photo #:</p> <ul style="list-style-type: none"> • Reconfigure or replace handrails • •
<p>2.18 If the handrail gripping surface is circular, is it no less than 1 ¼ inches and no greater than 2 inches in diameter? [505.7.1]</p>	<p><input type="checkbox"/> Yes <input type="checkbox"/> No Measurement:</p>		<p>Photo #:</p> <ul style="list-style-type: none"> • Replace handrails • •

2.19 If the handrail gripping surface is non-circular:

Is the perimeter no less than 4 inches and no greater than 6 1/4 inches?

Yes No

Measurement:

Is the cross section no greater than 2 1/4 inches in diameter? [505.7.2]

Yes No

Measurement:

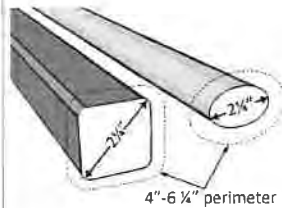

Photo #:

- Replace handrails
-
-

2.20 Does the handrail:

Extend at least 12 inches horizontally beyond the top and bottom of the ramp?

Yes No

Measurement:

Return to a wall, guard, or landing surface? [505.10.1]

Yes No

Note: If a 12" extension would be hazardous (in circulation path), it is not required

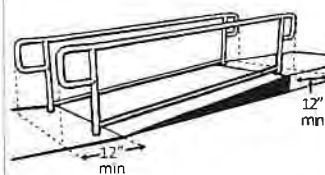

Photo #:

- Alter handrails
-
-

2.21 To prevent wheelchair casters and crutch tips from falling off:

Does the surface of the ramp extend at least 12 inches beyond the inside face of the handrail?

Yes No

Measurement:

Or

Yes No

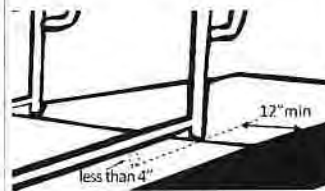
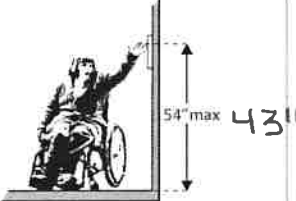
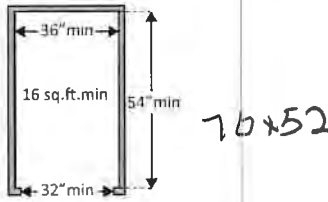
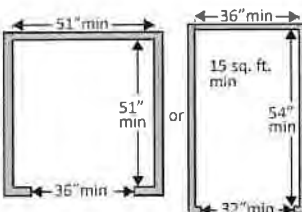

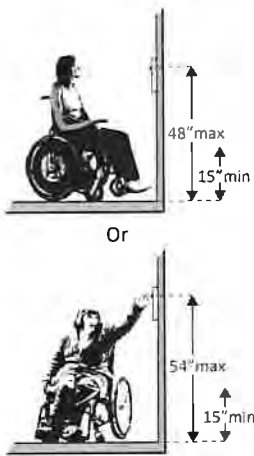

Photo #:

- Add curb
- Add barrier
- Extend ramp width
-
-

<p>Is there a curb or barrier that prevents the passage of a 4-inch diameter sphere? [405.9.1, 405.9.2]</p>	<p>Measurement:</p>		<p>Photo #:</p>	
-----------------------------------------------------------------------------------------------------------------	---------------------	--	-----------------	--

<p>Elevators – Full Size & LULA (limited use, limited application) LULA elevators are often used in alterations.</p>				
<p>2.22 If there is a full size or LULA elevator, are the call buttons no higher than 54 inches above the floor? [407.2.1.1]</p>	<p><input checked="" type="checkbox"/> Yes <input type="checkbox"/> No Measurement: 43"</p>		<p>Photo #:</p>	<ul style="list-style-type: none"> • Change call button height • •
<p>2.23 If there is a full size or LULA elevator, does the sliding door reopen automatically when obstructed by an object or person?*</p>	<p><input checked="" type="checkbox"/> Yes <input type="checkbox"/> No</p>		<p>Photo #:</p>	<p>* If constructed before 3/15/2012 and manually operated, the door is not required to reopen automatically</p> <ul style="list-style-type: none"> • Install opener •

<p>2.24 If there is a LULA elevator with a swinging door:</p> <p>Is the door power-operated? <input type="checkbox"/> Yes <input type="checkbox"/> No</p> <p>Does the door remain open for at least 20 seconds when activated? <input type="checkbox"/> Yes <input checked="" type="checkbox"/> No</p> <p>[403.3.2]</p>	<p>Time: 8</p>		<p>Photo #:</p>	<ul style="list-style-type: none"> • Add power operated door • Adjust opening time
<p>2.25 If there is a full size elevator:</p> <p>Is the interior at least 54 inches deep by at least 36 inches wide with at least 16 sq. ft. of clear floor area? <input checked="" type="checkbox"/> Yes <input type="checkbox"/> No</p> <p>Measurement: 52" x 70"</p> <p>Is the door opening width at least 32 inches? <input checked="" type="checkbox"/> Yes <input type="checkbox"/> No</p> <p>[407.4.1 Exception]</p>	<p>Measurement: 36"</p>		<p>Photo #:</p>	<ul style="list-style-type: none"> • Replace elevator
<p>2.26 If there is a LULA elevator, is the interior:</p> <p>At least 51 inches deep by 51 inches wide with a door opening width of at least 36 inches? <input checked="" type="checkbox"/> Yes <input type="checkbox"/> No</p> <p>Measurement: 52" x 70"</p> <p>Or</p> <p>At least 54 inches deep by at least 36 inches wide with at least 15 sq. ft. of clear floor area and a door opening width of at least 32 inches? <input checked="" type="checkbox"/> Yes <input type="checkbox"/> No</p> <p>Measurement: 52" x 70"</p> <p>[408.4.1 Exceptions 1 and 2]</p>	<p>Measurement: 52" x 70"</p>		<p>Photo #:</p>	<ul style="list-style-type: none"> • Replace elevator

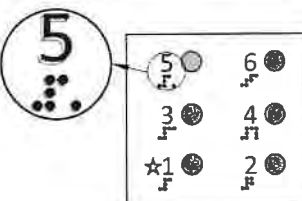
<p>2.27 If there is a full size or LULA elevator, are the in-car controls:</p> <p>No less than 15 inches and no greater 48 inches above the floor?</p> <p>Or</p> <p>Up to 54 inches above the floor for a parallel approach? [408.4.6, 407.4.6.1]</p>	<p><input checked="" type="checkbox"/> Yes <input type="checkbox"/> No</p> <p>Measurement: 36"</p> <p><input checked="" type="checkbox"/> Yes <input type="checkbox"/> No</p> <p>Measurement: 42"</p>		<p>Photo #:</p>	<ul style="list-style-type: none"> • Change control height • •
<p>2.28 If there is a LULA elevator, are the in-car controls centered on a side wall?</p> <p>[408.4.6]</p>	<p><input type="checkbox"/> Yes <input checked="" type="checkbox"/> No</p> <p>Measurement: 17"</p>		<p>Photo #:</p>	<ul style="list-style-type: none"> • Reconfigure controls • •
<p>2.29 If there is a full size or LULA elevator:</p> <p>Are the car control buttons designated with raised characters?</p> <p>Are the car control buttons designated with Braille?</p>	<p><input checked="" type="checkbox"/> Yes <input type="checkbox"/> No</p> <p><input checked="" type="checkbox"/> Yes <input type="checkbox"/> No</p>		<p>Photo #:</p>	<ul style="list-style-type: none"> • Add raised characters • Add Braille •

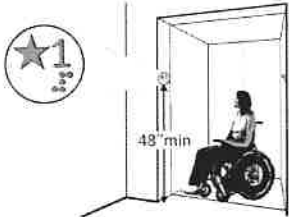

36"
42"

[407.4.7.1, 703.2]			Photo #:	
<p>2.30 If there is a full size or LULA elevator, are there audible signals which sound as the car passes or is about to stop at a floor? [407.4.8]</p>	<p><input checked="" type="checkbox"/> Yes <input type="checkbox"/> No</p>		Photo #:	<ul style="list-style-type: none"> • Install audible signals • •
<p>2.31 If there is a full size or LULA elevator:</p> <p>Is there a sign on both door jambs at every floor identifying the floor?</p> <p>Is there a tactile star on both jambs at the main entry level?</p> <p>Do text characters contrast with their backgrounds?</p> <p>Are text characters raised?</p> <p>Is there Braille?</p> <p>Is the sign mounted between 48 inches to the baseline of the lowest character and 60 inches to the baseline of the highest character above the floor?*</p> <p>[407.2.3, 408.2.3]</p>	<p><input checked="" type="checkbox"/> Yes <input type="checkbox"/> No</p> <p><input checked="" type="checkbox"/> Yes <input type="checkbox"/> No</p> <p><input checked="" type="checkbox"/> Yes <input type="checkbox"/> No</p> <p><input checked="" type="checkbox"/> Yes <input type="checkbox"/> No</p> <p><input checked="" type="checkbox"/> Yes <input type="checkbox"/> No</p> <p><input type="checkbox"/> Yes <input checked="" type="checkbox"/> No</p> <p>Measurement: 36" 42"</p>		Photo #:	<ul style="list-style-type: none"> • Install signs • Change sign height • • <p>* If constructed before 3/15/2012 and mounted no higher than 60 inches to the centerline of the sign, relocation is not required</p>
Platform Lifts				

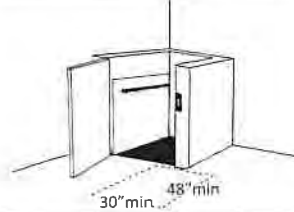
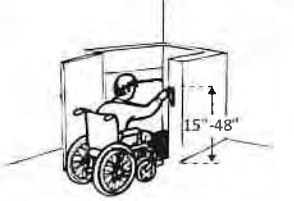
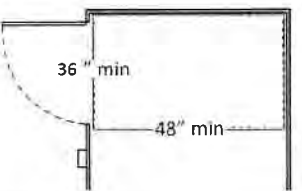
NA

<p>2.32 If a lift is provided, can it be used without assistance from others? [410.1]</p>	<p><input type="checkbox"/> Yes <input type="checkbox"/> No</p>		<p>Photo #:</p>	<ul style="list-style-type: none"> • Reconfigure so independently operable • •
<p>2.33 Is there a clear floor space at least 30 inches wide by at least 48 inches long for a person using a wheelchair to approach and reach the controls to use the lift? [410.5]</p>	<p><input type="checkbox"/> Yes <input type="checkbox"/> No Measurement:</p>		<p>Photo #:</p>	<ul style="list-style-type: none"> • Remove obstructions • •
<p>2.34 Are the lift controls no less than 15 inches and no greater than 48 inches above the floor? [410.5]</p>	<p><input type="checkbox"/> Yes <input type="checkbox"/> No Measurement:</p>		<p>Photo #:</p>	<ul style="list-style-type: none"> • Change control height • •
<p>2.35 Is there a clear floor space at least 36 inches wide by at least 48 inches long inside the lift? [410.3]</p>	<p><input type="checkbox"/> Yes <input type="checkbox"/> No Measurement:</p>		<p>Photo #:</p>	<ul style="list-style-type: none"> • Replace lift • •

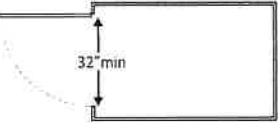
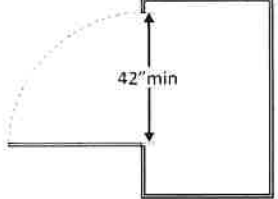
NA

<p>2.36 If there is an end door, is the clear opening width at least 32 inches? [410.6]</p>	<p><input type="checkbox"/> Yes <input type="checkbox"/> No</p> <p>Measurement:</p>		<p>Photo #:</p>	<ul style="list-style-type: none"> • Alter door width • •
<p>2.37 If there is a side door, is the clear opening width at least 42 inches? [410.6]</p>	<p><input type="checkbox"/> Yes <input type="checkbox"/> No</p> <p>Measurement:</p>		<p>Photo #:</p>	<ul style="list-style-type: none"> • Alter door width • •
<p>Signs "Tactile characters" are read using touch, i.e. raised characters and Braille.</p>				
<p>2.38 If there are signs designating permanent rooms and spaces not likely to change over time, e.g. room numbers and letters, room names, and exit signs: [216.2]</p> <p>Do text characters contrast with their backgrounds? [703.5]</p> <p>Are text characters raised? [703.2]</p> <p>Is there Braille? [703.3]</p> <p>Is the sign mounted:</p>	<p><input type="checkbox"/> Yes <input type="checkbox"/> No</p> <p><input type="checkbox"/> Yes <input type="checkbox"/> No</p> <p><input type="checkbox"/> Yes <input type="checkbox"/> No</p>		<p>Photo #:</p>	<ul style="list-style-type: none"> • Install tactile sign • Relocate sign •

NA

On the wall on the latch side of the door?
[703.4.2]

Yes No

Note: Signs are permitted on the push side of doors with closers and without hold-open devices.

With clear floor space beyond the arc of the door swing between the closed position and 45-degree open position, at least 18 x 18 inches centered on the tactile characters?*

Yes No

Measurement:

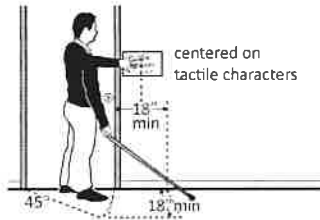

So the baseline of the lowest character is at least 48 inches above the floor and the baseline of the highest character is no more than 60 inches above the floor? *

Yes No

Measurement:

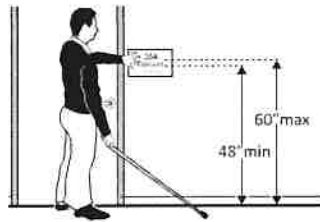

Note: If the sign is at double doors with one active leaf, the sign should be on the inactive leaf; if both leaves are active, the sign should be on the wall to the right of the right leaf.

Photo #:

*If constructed before 3/15/2012 and a person may approach within 3 inches of the sign without encountering protruding objects or standing within the door swing, relocation not required

*If constructed before 3/15/2012 and mounted no higher than 60 inches to the centerline of the sign, relocation not required

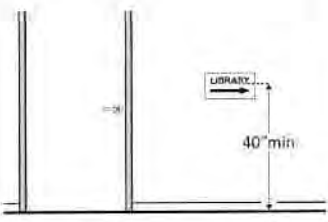
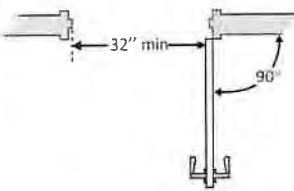
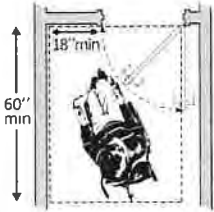

NA

<p>2.39 If there are signs that provide direction to or information about interior spaces:</p> <p>Do text characters contrast with their backgrounds? [703.5.1]</p> <p>Is the sign mounted so that characters are at least 40 inches above the floor? [703.5.6]</p> <p>Note: Raised characters and Braille are not required.</p>	<p><input type="checkbox"/> Yes <input type="checkbox"/> No</p> <p><input type="checkbox"/> Yes <input type="checkbox"/> No</p> <p>Measurement:</p>		<p>Photo #:</p>	<ul style="list-style-type: none"> • Install signs with contrasting characters • Change sign height
Interior Doors – to classrooms, medical exam rooms, conference rooms, etc.				
<p>2.40 Is the door opening width at least 32 inches clear, between the face of the door and the stop, when the door is open 90 degrees? [404.2.3]</p>	<p><input type="checkbox"/> Yes <input type="checkbox"/> No</p> <p>Measurement:</p>		<p>Photo #:</p>	<ul style="list-style-type: none"> • Install offset hinges • Alter the doorway
<p>2.41 If there is a front approach to the pull side of the door, is there at least 18 inches of maneuvering clearance beyond the latch side plus at least 60 inches clear depth?</p> <p>Note: See 2010 Standards 404.2.4 for maneuvering clearance requirements on the push side of the door and side approaches to the pull side of the door.</p>	<p><input type="checkbox"/> Yes <input type="checkbox"/> No</p> <p>Measurement:</p>		<p>Photo #:</p>	<ul style="list-style-type: none"> • Remove obstructions • Reconfigure walls • Add automatic door opener

NA

<p>On both sides of the door, is the floor surface of the maneuvering clearance level (no steeper than 1:48)? [404.2.4]</p>	<p><input type="checkbox"/> Yes <input type="checkbox"/> No Measurement:</p>		<p>Photo #:</p>	
<p>2.42 If the threshold is vertical is it no more than ¼ inch high?</p> <p>Or</p> <p>No more than ½ inch high with the top ¼ inch beveled no steeper than 1:2, if the threshold was installed on or after the 1991 ADA Standards went into effect (1/26/93)?</p> <p>Or</p> <p>No more than ¾ inch high with the top ½ inch beveled no steeper than 1:2, if the threshold was installed before the 1991 ADA Standards went into effect (1/26/93)? [404.2.5, 303.2]</p> <p>Note: The first ¼ inch of the ½ or ¾ inch threshold may be vertical; the rest must be beveled.</p>	<p><input type="checkbox"/> Yes <input type="checkbox"/> No Measurement:</p> <p><input type="checkbox"/> Yes <input type="checkbox"/> No Measurement:</p> <p><input type="checkbox"/> Yes <input type="checkbox"/> No Measurement:</p>		<p>Photo #:</p>	<ul style="list-style-type: none"> • Remove or replace threshold • •

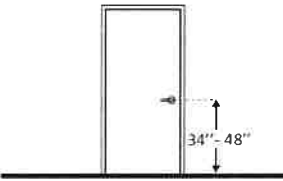
NA

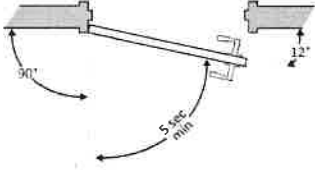
<p>2.43 Is the door equipped with hardware that is operable with one hand and does not require tight grasping, pinching or twisting of the wrist?</p> <p>Door handle?</p> <p>Lock (if provided)? [404.2.7]</p>	<p><input type="checkbox"/> Yes <input type="checkbox"/> No</p> <p><input type="checkbox"/> Yes <input type="checkbox"/> No</p> <p><input type="checkbox"/> Yes <input type="checkbox"/> No</p>		<p>Photo #:</p>	<ul style="list-style-type: none"> • Replace inaccessible knob with lever, loop or push hardware • Add automatic door opener •
<p>2.44 Are the operable parts of the hardware no less than 34 inches and no greater than 48 inches above the floor? [404.2.7]</p>	<p><input type="checkbox"/> Yes <input type="checkbox"/> No</p> <p>Measurement:</p>		<p>Photo #:</p>	<ul style="list-style-type: none"> • Change hardware height • •
<p>2.45 Can the door be opened easily (5 pounds maximum force)? [404.2.9]</p> <p>Note: You can use a pressure gauge or fish scale to measure force. If you do not have one you will need to judge whether the door is easy to open.</p>	<p><input type="checkbox"/> Yes <input type="checkbox"/> No</p> <p>Measurement:</p>		<p>Photo #:</p>	<ul style="list-style-type: none"> • Adjust or replace closers • Install lighter doors • Install power-assisted or automatic door openers
<p>2.46 If the door has a closer, does it take at least 5 seconds to close from an open position of 90 degrees to a position of 12 degrees from the latch? [404.2.8.1]</p>	<p><input type="checkbox"/> Yes <input type="checkbox"/> No</p> <p>Measurement:</p>		<p>Photo #:</p>	<ul style="list-style-type: none"> • Adjust closer • •

Rooms and Spaces – stores, supermarkets, libraries, etc.

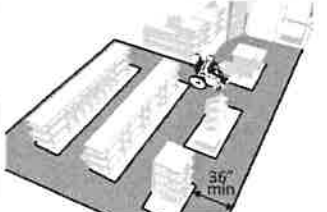
<p>2.47 Are aisles and pathways to goods and services, and to one of each type of sales and service counters, at least 36 inches wide? [403.5.1]</p>	<p><input type="checkbox"/> Yes <input type="checkbox"/> No</p> <p>Measurement:</p>		<p>Photo #:</p>	<ul style="list-style-type: none"> • Rearrange goods, equipment and furniture • •
-----------------------------------------------------------------------------------------------------------------------------------------------------------------	-------------------------------------------------------------------------------------	------------------------------------------------------------------------------------	-----------------	--------------------------------------------------------------------------------------------------------------------

<p>2.48 Are floor surfaces stable, firm and slip resistant? [302.1]</p>	<p><input type="checkbox"/> Yes <input type="checkbox"/> No</p>	<p>Photo #:</p>	<p>Photo #:</p>	<ul style="list-style-type: none"> • Change floor surface • •
------------------------------------------------------------------------------------	-----------------------------------------------------------------	-----------------	-----------------	------------------------------------------------------------------------------------------------

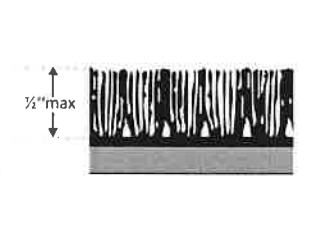
<p>2.49 If there is carpet:</p> <p>Is it no higher than 1/2 inch?</p> <p>Is it securely attached along the edges?</p> <p>[302.2]</p>	<p><input type="checkbox"/> Yes <input type="checkbox"/> No</p> <p>Measurement:</p> <p><input type="checkbox"/> Yes <input type="checkbox"/> No</p>		<p>Photo #:</p>	<ul style="list-style-type: none"> • Replace carpet • •
---------------------------------------------------------------------------------------------------------------------------------------------	-----------------------------------------------------------------------------------------------------------------------------------------------------	-------------------------------------------------------------------------------------	-----------------	------------------------------------------------------------------------------------------

Controls – light switches, security and intercom systems, emergency/alarm boxes, etc.

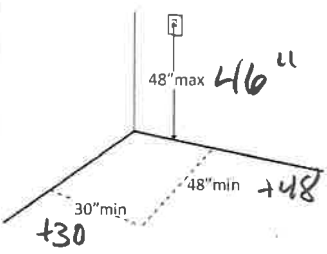
<p>2.50 Is there a clear floor space at least 30 inches wide by at least 48 inches long for a forward or parallel approach? [305.3]</p> <p>Are the operable parts no higher than 48 inches above the floor?*</p> <p>[309.3, 308]</p>	<p><input type="checkbox"/> Yes <input type="checkbox"/> No</p> <p>Measurement:</p> <p><input type="checkbox"/> Yes <input type="checkbox"/> No</p> <p>Measurement:</p>		<p>Photo #:</p>	<ul style="list-style-type: none"> • Change height of control • • <p>*If constructed before 3/15/2012 and a parallel approach is provided, controls can be 54 inches above the floor</p>
-------------------------------------------------------------------------------------------------------------------------------------------------------------------------------------------------------------------------------------------------	-------------------------------------------------------------------------------------------------------------------------------------------------------------------------	--------------------------------------------------------------------------------------	-----------------	---------------------------------------------------------------------------------------------------------------------------------------------------------------------------------------------------------------------------

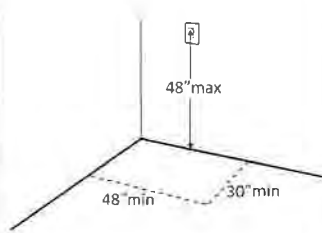

Photo #:

2.51 Can the control be operated with one hand and without tight grasping, pinching, or twisting of the wrist? [309.4]

Yes No



Photo #:

- Replace control
-
-

Seating: Assembly Areas – theaters, auditoriums, stadiums, theater style classrooms, etc.

2.52 Are an adequate number of wheelchair spaces provided? [221.2.1]

Yes No

Total #:

Wheelchair #:

# of Seats	Wheelchair Spaces
4 - 25	1
26 - 50	2
51 - 150	4
151 - 300	5
300+ see 2010 Standards 221.2.1.	

Photo #:



- Reconfigure to add wheelchair spaces
-
-

2.53 Are wheelchair spaces dispersed to allow location choices and viewing angles equivalent to other seating, including specialty seating areas that provide distinct services and amenities? [221.2.3]

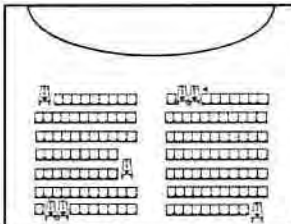

Yes No

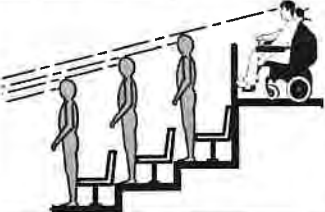

- Reconfigure to disperse wheelchair spaces
-
-

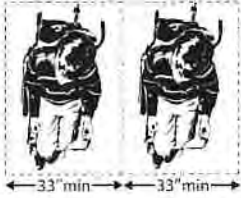
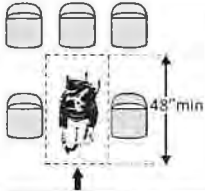
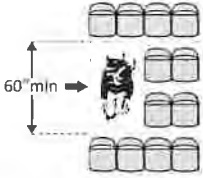
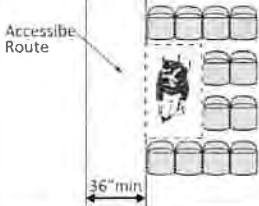
			Photo #:	
<p>2.54 Where people are expected to remain seated, do people in wheelchair spaces have a clear line of sight over and between the heads of others in front of them? [802.2.1.1, 802.1.1.2]</p>	<p><input type="checkbox"/> Yes <input type="checkbox"/> No</p>		Photo #:	<ul style="list-style-type: none"> • Alter for line of sight • •
<p>2.55 Where people are expected to stand, do people in wheelchair spaces have a clear line of sight over and between the heads of others in front of them? [802.2.2.1, 802.1.2.2]</p>	<p><input type="checkbox"/> Yes <input type="checkbox"/> No</p>		Photo #:	<ul style="list-style-type: none"> • Alter for line of sight • •
<p>2.56 If there is a single wheelchair space, is it at least 36 inches wide? [802.1.2]</p>	<p><input type="checkbox"/> Yes <input type="checkbox"/> No</p> <p>Measurement:</p>		Photo #:	<ul style="list-style-type: none"> • Alter space • •

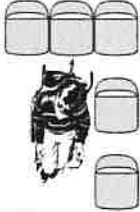
<p>2.57 If there are two adjacent wheelchair spaces, are they each at least 33 inches wide? [802.1.2]</p>	<p><input type="checkbox"/> Yes <input type="checkbox"/> No Measurement:</p>		<p>Photo #:</p>	<ul style="list-style-type: none"> • Alter spaces • •
<p>2.58 If the wheelchair space can be entered from the front or rear, is it at least 48 inches deep? [802.1.3]</p>	<p><input type="checkbox"/> Yes <input type="checkbox"/> No Measurement:</p>		<p>Photo #:</p>	<ul style="list-style-type: none"> • Alter space • •
<p>2.59 If the wheelchair space can only be entered from the side, is it at least 60 inches deep? [802.1.3]</p>	<p><input type="checkbox"/> Yes <input type="checkbox"/> No Measurement:</p>		<p>Photo #:</p>	<ul style="list-style-type: none"> • Alter space • •
<p>2.60 Do wheelchair spaces adjoin, but not overlap, accessible routes? [802.1.4]</p>	<p><input type="checkbox"/> Yes <input type="checkbox"/> No</p>		<p>Photo #:</p>	<ul style="list-style-type: none"> • Alter spaces • •

<p>2.61 Is there at least one companion seat for each wheelchair space? [221.3]</p>	<p><input type="checkbox"/> Yes <input type="checkbox"/> No</p>		<p>Photo #:</p>	<ul style="list-style-type: none"> • Add companion seats • •
<p>2.62 Is the companion seat located so the companion is shoulder-to-shoulder with the person in a wheelchair? [802.3.1]</p>	<p><input type="checkbox"/> Yes <input type="checkbox"/> No</p>		<p>Photo #:</p>	<ul style="list-style-type: none"> • Alter seating • •
<p>2.63 Is the companion seat equivalent in size, quality, comfort and amenities to seating in the immediate area? [802.3.2]</p>	<p><input type="checkbox"/> Yes <input type="checkbox"/> No</p>		<p>Photo #:</p>	<ul style="list-style-type: none"> • Add equivalent seating • •
<p>Seating: At dining surfaces (restaurants, cafeterias, bars, etc.) and non-employee work surfaces (libraries, conference rooms, etc.)</p>				
<p>2.64 Are at least 5%, but no fewer than one, of seating and standing spaces accessible for people who use wheelchairs? [226.1]</p>	<p><input type="checkbox"/> Yes <input type="checkbox"/> No</p> <p>Total #: Wheelchair #:</p>		<p>Photo #:</p>	<ul style="list-style-type: none"> • Alter to provide accessible spaces • •
<p>2.65 Is there a route at least 36 inches wide to accessible seating? [403.5.1]</p>	<p><input type="checkbox"/> Yes <input type="checkbox"/> No</p> <p>Measurement:</p>		<p>Photo #:</p>	<ul style="list-style-type: none"> • Widen route • •

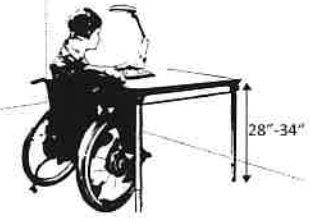
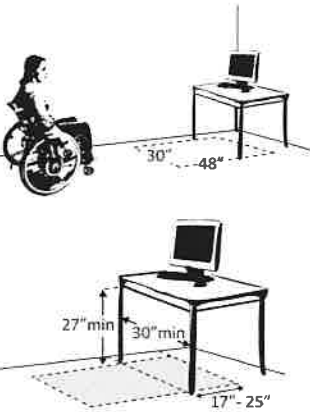
<p>2.66 At the accessible space(s), is the top of the accessible surface no less than 28 inches and no greater than 34 inches above the floor? [902.3]</p> <p>Note: If for children, the top should be no less than 26 inches and no greater than 30 inches above the floor.</p>	<p><input type="checkbox"/> Yes <input type="checkbox"/> No</p> <p>Measurement:</p>		<p>Photo #:</p> <ul style="list-style-type: none"> • Alter surface height • •
<p>2.67 Is there a clear floor space at least 30 inches wide by at least 48 inches long for a forward approach? [305.3]</p> <p>Does it extend no less than 17 inches and no greater than 25 inches under the surface?</p> <p>Is there knee space at least 27 inches high and at least 30 inches wide? [306.2, 306.3]</p> <p>Note: If for children, the knee space may be 24 inches high.</p>	<p><input type="checkbox"/> Yes <input type="checkbox"/> No</p> <p>Measurement:</p> <p><input type="checkbox"/> Yes <input type="checkbox"/> No</p> <p>Measurement:</p> <p><input type="checkbox"/> Yes <input type="checkbox"/> No</p> <p>Measurement:</p>		<p>Photo #:</p> <ul style="list-style-type: none"> • Alter table or work surface • Add accessible table or work surface •

Seating: General – reception areas, waiting rooms, etc.

2.68 Is there at least one space at least 36 inches wide by at least 48 inches long for a person in a wheelchair?
[802.1.2, 802.1.3]

Yes No

Measurement:

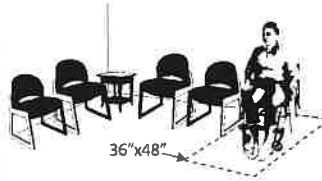

Photo #:

- Move furniture and equipment to provide space
-
-

Benches – In locker rooms, dressing rooms, fitting rooms This section does not apply to any other benches.

2.69 In locker rooms, dressing rooms and fitting rooms, is there at least one room with a bench?
[222.1, 803.4]

Yes No

Photo #:

- Add bench
-
-

2.70 Is there a clear floor space at least 30 inches wide by at least 48 inches long at the end of the bench and parallel to the short axis of the bench?

Yes No

Measurement:

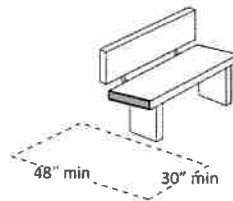

Is the bench seat at least 42 inches long and no less than 20 inches and no greater than 24 inches deep?

Yes No

Measurement:

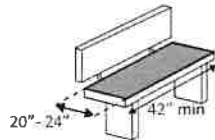

Does the bench have back support or is it affixed to a wall?

Yes No



Is the top of the bench seat no less than 17 inches and no greater than 19 inches above the floor?
[903]

Yes No

Measurement:

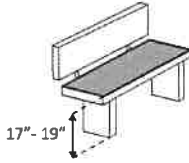
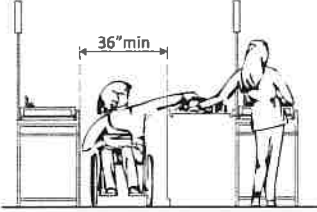
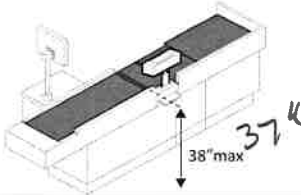
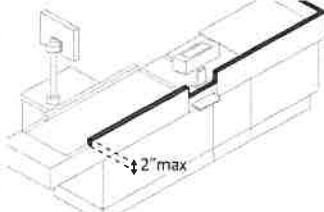
- Move bench
- Replace bench
- Affix bench to wall
-
-

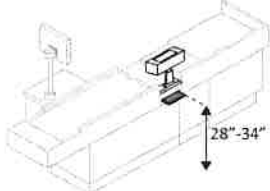
			<p>Photo #:</p>	
Check-Out Aisles – supermarkets, large retail stores, etc.				
<p>2.71 Is the aisle at least 36 inches wide? [904.3.1]</p>	<p><input type="checkbox"/> Yes <input type="checkbox"/> No</p> <p>Measurement:</p>		<p>Photo #:</p>	<ul style="list-style-type: none"> • Widen aisle • •
<p>2.72 Is the counter surface of at least one aisle no higher than 38 inches above the floor? [904.3.2]</p>	<p><input type="checkbox"/> Yes <input type="checkbox"/> No</p> <p>Measurement:</p>		<p>Photo #:</p>	<ul style="list-style-type: none"> • Lower counter • •
<p>2.73 Is the top of the counter edge protection no higher than 2 inches above the counter surface? [904.3.2]</p>	<p><input type="checkbox"/> Yes <input type="checkbox"/> No</p> <p>Measurement:</p>		<p>Photo #:</p>	<ul style="list-style-type: none"> • Lower edge protection • •

<p>2.74 If there is a check writing surface, is the top no less than 28 inches and no greater than 34 inches above the floor? [904.3.3]</p>	<p><input type="checkbox"/> Yes <input type="checkbox"/> No Measurement:</p>		<p>Photo #:</p>	<ul style="list-style-type: none"> • Alter check writing surface • •
<p>2.75 If there is more than one check-out aisle is there a sign with the International Symbol of Accessibility at the accessible aisle? [216.11]</p>	<p><input type="checkbox"/> Yes <input type="checkbox"/> No</p>		<p>Photo #:</p>	<ul style="list-style-type: none"> • Add sign • •

Sales & Service Counters – banks, stores, dry cleaners, auto repair shops, fitness clubs, etc.

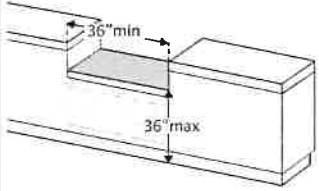
<p>2.76 Is there a portion of at least one of each type of counter that is: No higher than 36 inches above the floor? At least 36 inches long? [904.4.1]</p>	<p><input type="checkbox"/> Yes <input type="checkbox"/> No Measurement: <input type="checkbox"/> Yes <input type="checkbox"/> No Measurement:</p>		<p>Photo #:</p>	<ul style="list-style-type: none"> • Lower section of counter • Lengthen section of counter •
---------------------------------------------------------------------------------------------------------------------------------------------------------------------------------------	---------------------------------------------------------------------------------------------------------------------------------------------------------------------	--------------------------------------------------------------------------------------	-----------------	--------------------------------------------------------------------------------------------------------------------------------

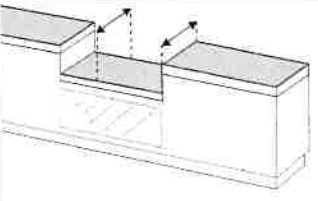
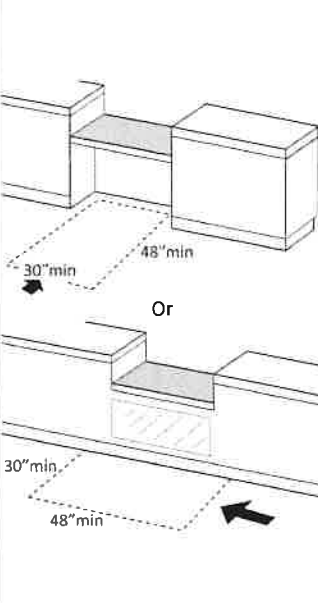
<p>2.77 Does the accessible portion of the counter extend the same depth as the counter top? [904.4]</p>	<p><input type="checkbox"/> Yes <input type="checkbox"/> No</p> <p>Measurement:</p>		<p>Photo #:</p>	<ul style="list-style-type: none"> • Alter accessible portion • •
<p>2.78 Is there a clear floor space at least 30 inches wide by at least 48 inches long for a forward or parallel approach? [904.4]</p>	<p><input type="checkbox"/> Yes <input type="checkbox"/> No</p> <p><input type="checkbox"/> Parallel Measurement:</p> <p><input type="checkbox"/> Forward Measurement:</p>		<p>Photo #:</p>	<ul style="list-style-type: none"> • Reconfigure to provide a parallel or forward approach • •

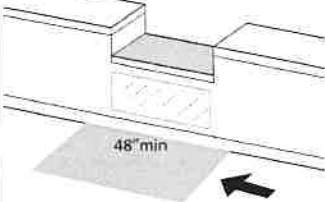
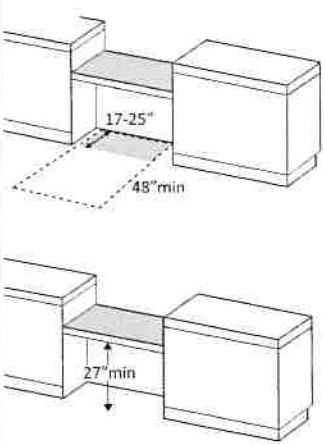
<p>2.79 For a parallel approach, is the clear floor space positioned with the 48 inches adjacent to the accessible length of counter? [904.4.1]</p>	<p><input type="checkbox"/> Yes <input type="checkbox"/> No Measurement:</p>		<p>Photo #:</p>	<ul style="list-style-type: none"> • If a parallel approach is not possible, a forward approach is required • •
<p>2.80 For a forward approach:</p> <p>Do no less than 17 and no greater than 25 inches of the clear floor space extend under the accessible length of the counter? [306.2.2, 306.2.3]</p> <p>Is there at least 27 inches clearance from the floor to the bottom of the counter? [306.3.1]</p>	<p><input type="checkbox"/> Yes <input type="checkbox"/> No Measurement:</p> <p><input type="checkbox"/> Yes <input type="checkbox"/> No Measurement:</p>		<p>Photo #:</p>	<ul style="list-style-type: none"> • Reconfigure to provide knee clearance • •

Food Service Lines – in cafeterias, salad bars, eat-in fast food establishments, etc.

2.81 Does at least one of each type of self-service shelf or dispensing device for tableware, dishware, condiments, food and beverages have a forward or parallel approach? [904.5.1]

- Yes No
- Forward
- Parallel

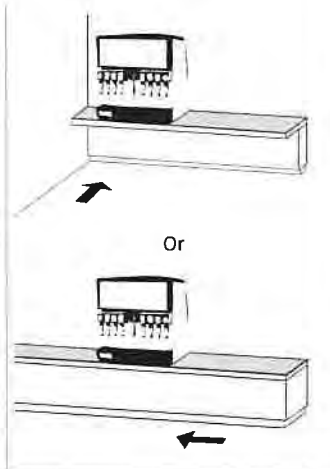

Photo #:

- Reconfigure to provide approach
-
-

2.82 If there is an unobstructed parallel approach, is the shelf or dispensing device no higher than 48 inches above the floor? [308.3.1]

- Yes No
- Measurement:

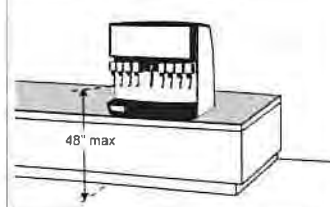

Photo #:

- Lower shelf and/or dispensing device
-
-

2.83 If there is a shallow obstruction no deeper than 10 inches with a parallel approach, is the shelf or dispensing device no higher than 48 inches above the floor? [308.3.1]

- Yes No
- Measurement:

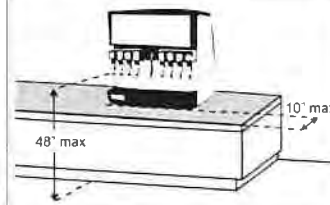
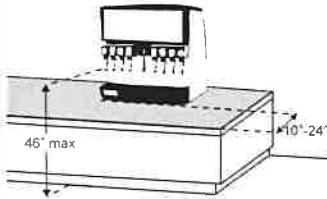
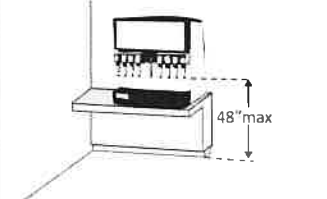
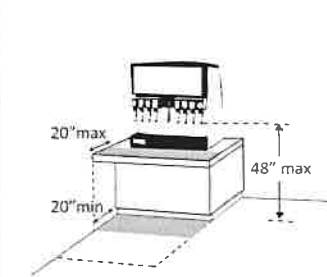
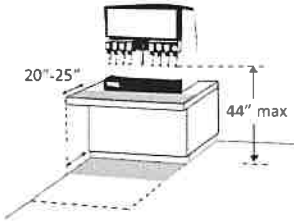





Photo #:

- Lower shelf and/or dispensing device
-
-

5" MICROWAVE

<p>2.84 If there is an obstruction no less than 10 inches and no greater than 24 inches deep with a parallel approach, is the shelf or dispensing device no higher than 46 inches above the floor? [308.3.2]</p>	<p><input type="checkbox"/> Yes <input type="checkbox"/> No Measurement:</p>		<p>Photo #:</p>	<ul style="list-style-type: none"> • Lower shelf and/or dispensing device • •
<p>2.85 If there is an unobstructed forward approach, is the shelf or dispensing device no higher than 48 inches above the floor? [308.2.1]</p>	<p><input type="checkbox"/> Yes <input type="checkbox"/> No Measurement:</p>		<p>Photo #:</p>	<ul style="list-style-type: none"> • Lower shelf and/or dispensing device • •
<p>2.86 If there is an obstruction no deeper than 20 inches with a forward approach: Does clear floor space extend under the obstruction that is at least the same depth as the obstruction? Is the shelf or dispensing device no higher than 48 inches above the floor? [904.5.1]</p>	<p><input type="checkbox"/> Yes <input type="checkbox"/> No Measurement: <input type="checkbox"/> Yes <input type="checkbox"/> No Measurement:</p>		<p>Photo #:</p>	<ul style="list-style-type: none"> • Reconfigure to provide knee space • Lower shelf and/or dispensing device •

<p>2.87 If the obstruction is no less than 20 inches and no greater than 25 inches deep with a forward approach:</p> <p>Does clear floor space extend under the obstruction that is at least the same depth as the obstruction?</p> <p>Is the shelf or dispensing device no higher than 44 inches above the floor? [904.5.1]</p>	<p><input type="checkbox"/> Yes <input type="checkbox"/> No Measurement:</p> <p><input type="checkbox"/> Yes <input type="checkbox"/> No Measurement:</p>		<p>Photo #:</p>	<ul style="list-style-type: none"> • Reconfigure to provide knee space • Lower shelf and/or dispensing device •
<p>2.88 If there is a tray slide, is the top no less than 28 inches and no greater than 34 inches above the floor? [904.5.2]</p>	<p><input type="checkbox"/> Yes <input type="checkbox"/> No Measurement:</p>		<p>Photo #:</p>	<ul style="list-style-type: none"> • Reconfigure • •
<p><input type="checkbox"/> Yes <input type="checkbox"/> No</p>	<p>Measurement:</p>		<p>Photo #:</p>	<ul style="list-style-type: none"> • • •
<p><input type="checkbox"/> Yes <input type="checkbox"/> No</p>	<p>Measurement:</p>		<p>Photo #:</p>	<ul style="list-style-type: none"> • • •

The ADA Checklist for Existing Facilities

Priority 3 - Toilet Rooms

Based on the 2010 ADA Standards for Accessible Design

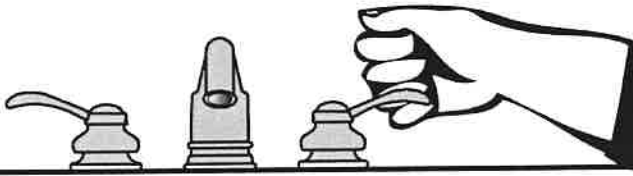

Project _____

Building _____

Location _____

Date _____

Surveyors _____

Contact Information _____

When toilet rooms are open to the public they should be accessible to people with disabilities.



Institute for Human Centered Design
www.HumanCenteredDesign.org
Copyright © 2016



ADA National Network
Questions on the ADA 800-949-4232 voice/tty
www.ADAchecklist.org

This checklist was produced by the New England ADA Center, a project of the Institute for Human Centered Design and a member of the ADA National Network. This checklist was developed under a grant from the Department of Education, NIDRR grant number H133A060092-09A. However the contents do not necessarily represent the policy of the Department of Education, and you should not assume endorsement by the Federal Government.

Questions or comments on the checklist contact the New England ADA Center at 617-695-0085 voice/tty or ADAinfo@NewEnglandADA.org

For the full set of checklists, including the checklists for recreation facilities visit www.ADAchecklist.org.

Copyright © 2016 ADA Checklist for Existing Materials. You can freely reproduce and distribute this content. Include proper attribution. But you must get permission before using this content as a fee-based product.

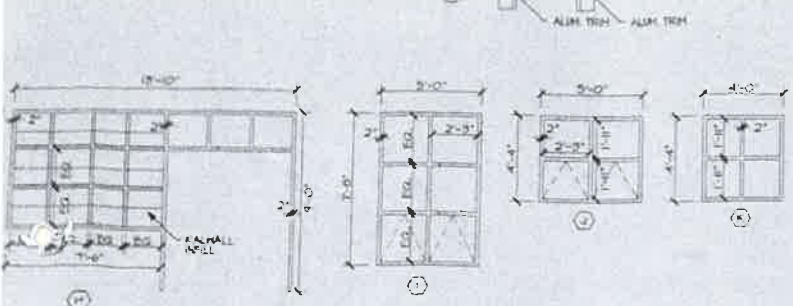

5 EXTERIOR WINDOW ELEVATIONS
1/4" = 1'-0"

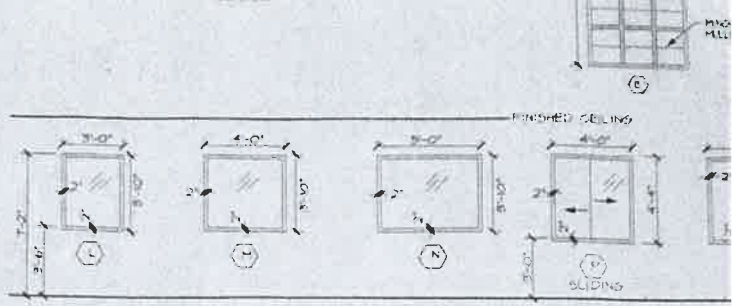

4 INTERIOR WINDOW ELEVATIONS
1/4" = 1'-0"

NOTE: ALL INTERIOR WINDOWS TO BE ALUMINUM STOREFRONT W/ 1/4" TEMPERED GLASS
NOTE: GLASS FOR INTERVIEW ROOM #1 TO BE ONE WAY MIRROR - VISION FROM DETECTIVE ROOM - SEE SPEC. FOR ADDITIONAL INFORMATION

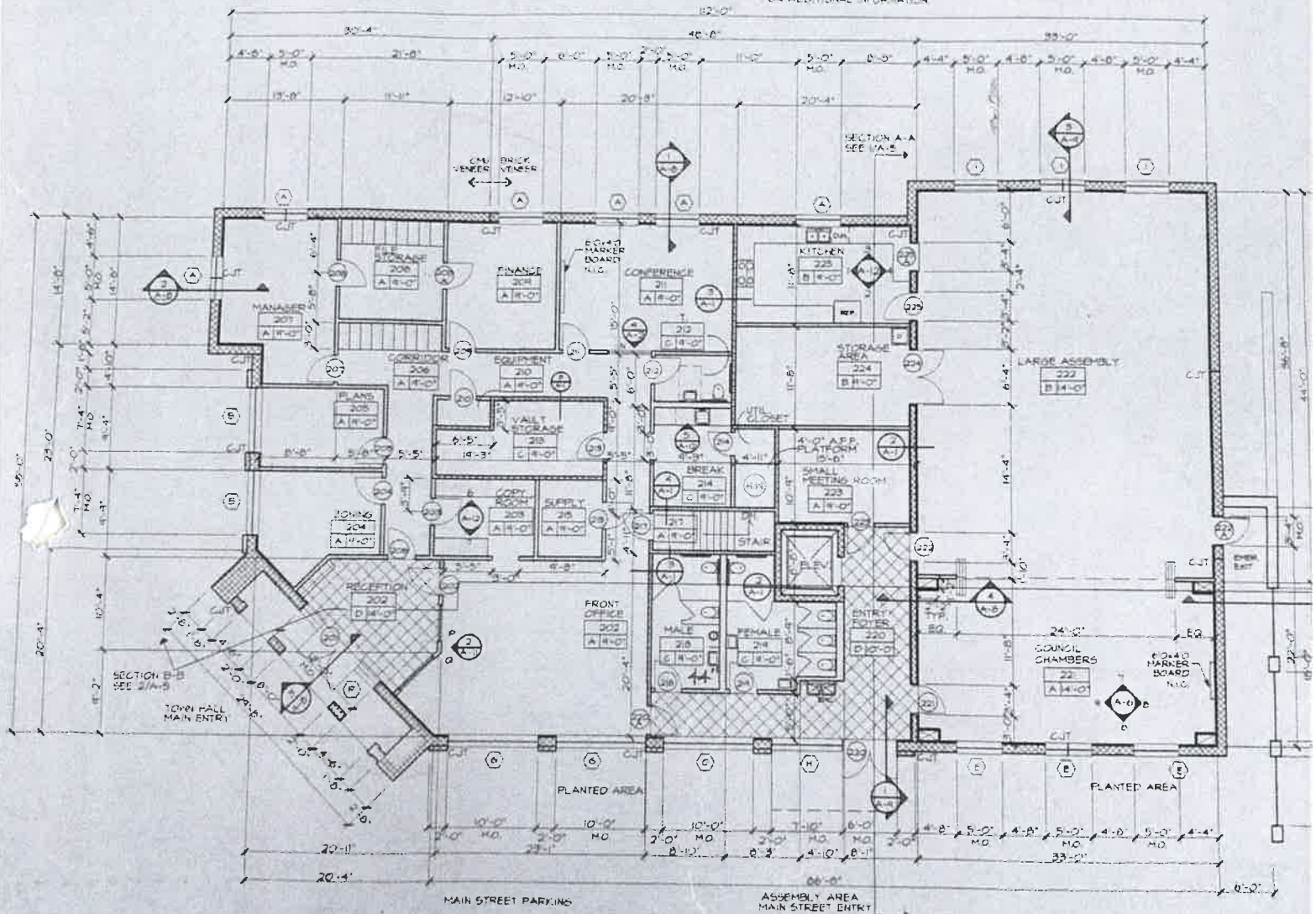

Town Hall

SECTION A-A SEE 1/A-5

SECTION B-B SEE 1/A-5

SECTION A-A SEE 1/A-5

SECOND FLOOR PLAN
1/8" = 1'-0"

SECOND FLOOR 6540 SF. TOTAL SQUARE FEET

CMU WALL

RATED WALL ASSEMBLY

PROJECT NORTH



Priority 3 – Toilet Rooms		Comments	Possible Solutions
<p>3.1 If toilet rooms are available to the public, is at least one toilet room accessible? (Either one for each sex, or one unisex.)</p> <p>Note: If toilet rooms are chiefly for children, e.g., in elementary schools and day care centers, use the children’s specifications in Toilets - 604.1, 604.8, 604.9, 609.4 and Lavatories and Sinks – 606.2.</p>	<input checked="" type="checkbox"/> Yes <input type="checkbox"/> No	<p>WILSON T WOMEN'S</p> <p>Photo #:</p>	<ul style="list-style-type: none"> • Reconfigure toilet rooms • Combine toilet rooms to create one unisex accessible toilet room
<p>3.2 Are there signs at inaccessible toilet rooms that give directions to accessible toilet rooms? [See 2010 ADA Standards for Accessible Design – 216.8]</p>	<input type="checkbox"/> Yes <input checked="" type="checkbox"/> No	 <p>Photo #:</p>	<ul style="list-style-type: none"> • Install signs
<p>3.3 If not all toilet rooms are accessible, is there a sign at the accessible toilet room with the International Symbol of Accessibility? [216.8]</p>	<input checked="" type="checkbox"/> Yes <input type="checkbox"/> No	 <p>Photo #:</p>	<ul style="list-style-type: none"> • Install sign
Accessible Route			
<p>3.4 Is there an accessible route to the accessible toilet room? [206.2.4]</p>	<input checked="" type="checkbox"/> Yes <input type="checkbox"/> No		<ul style="list-style-type: none"> • Alter route

Photo #:

Signs at Toilet Rooms

3.5 Do text characters contrast with their backgrounds? [703.5] Yes No

Are text characters raised? [703.2] Yes No

Is there Braille? [703.3] Yes No

Is the sign mounted: On the wall on the latch side of the door? [703.4.2] Yes No

Note: Signs are permitted on the push side of doors with closers and without hold-open devices.

With clear floor space beyond the arc of the door swing and 45-degree open position, at least 18 x 18 inches centered on the tactile characters? * [703.4.2] Yes No
Measurement:

So the baseline of the lowest character is at least 48 inches above the floor and the Yes No
Measurement:

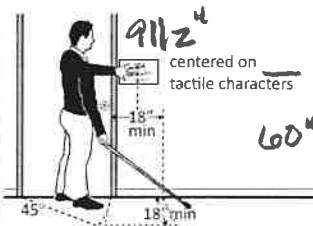
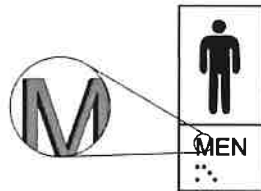

- Install tactile sign
- Relocate sign
-

*If constructed before 3/15/2012 and a person may approach within 3 inches of the sign without encountering protruding objects or standing within the door swing, relocation not required

baseline of the highest character is no more than 60 inches above the floor? * [703.4.1]

Note: If the sign is at double doors with one active leaf, the sign should be on the inactive leaf; if both leaves are active, the sign should be on the wall to the right of the right leaf.

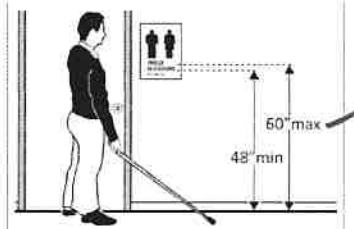

Photo #:

*If constructed before 3/15/2012 and mounted no higher than 60 inches to the centerline of the sign, relocation is not required

Entrance

3.6 Is the door opening width at least 32 inches clear, between the face of the door and the stop, when the door is open 90 degrees? [404.2.3]

Yes No

Measurement:

33"

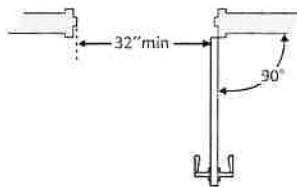

Photo #:

- Install offset hinges
- Alter the doorway
-

3.7 If there is a front approach to the pull side of the door is there at least 18 inches of maneuvering clearance beyond the latch side plus 60 inches clear depth?

Yes No

Measurement:

118"

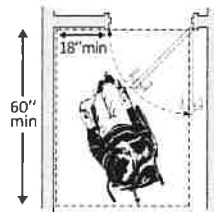

Photo #:

- Remove obstructions
- Reconfigure walls
- Add automatic door opener



Note: See 2010 Standards 404.2.4 for maneuvering clearance requirements on the push side of the door and side approaches to the pull side of the door

On both sides of the door, is the

ADA Checklist for Existing Facilities

Priority 3 – Toilet Rooms

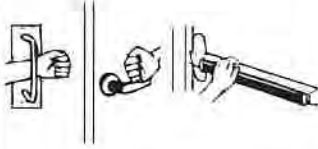
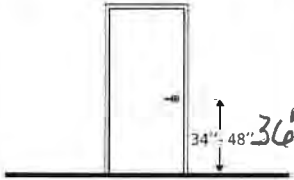
<p>floor surface of the maneuvering clearance level (no steeper than 1:48)? [404.2.4]</p>	<p><input checked="" type="checkbox"/> Yes <input type="checkbox"/> No Measurement: 0"</p>		<p>Photo #:</p>	
<p>3.8 NA If the threshold is vertical is it no more than ¼ inch high? Or No more than ½ inch high with the top ¼ inch beveled no steeper than 1:2, if the threshold was installed on or after the 1991 ADA Standards went into effect (1/26/93)? Or No more than ¾ inch high with the top ½ inch beveled no steeper than 1:2, if the threshold was installed before the 1991 ADA Standards went into effect (1/26/93)? [404.2.5, 303.2] Note: The first ¼ inch of the ½ or ¾ inch threshold may be vertical; the rest must be beveled.</p>	<p><input type="checkbox"/> Yes <input type="checkbox"/> No Measurement: NA <input type="checkbox"/> Yes <input type="checkbox"/> No Measurement: NA <input type="checkbox"/> Yes <input type="checkbox"/> No Measurement: NA</p>		<p>Photo #:</p>	<ul style="list-style-type: none"> • Remove or replace threshold • •

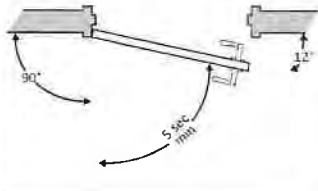
<p>3.9 Is the door equipped with hardware that is operable with one hand and does not require tight grasping, pinching or twisting of the wrist? Door handle? Lock (if provided)? [404.2.7]</p>	<p><input checked="" type="checkbox"/> Yes <input type="checkbox"/> No <input checked="" type="checkbox"/> Yes <input type="checkbox"/> No <input type="checkbox"/> Yes <input type="checkbox"/> No</p>		<p>Photo #:</p>	<ul style="list-style-type: none"> • Replace inaccessible knob with lever, loop or push hardware • Add automatic door opener •
<p>3.10 Are the operable parts of the door hardware mounted no less than 34 inches and no greater than 48 inches above the floor? [404.2.7]</p>	<p><input checked="" type="checkbox"/> Yes <input type="checkbox"/> No Measurement: 36"</p>		<p>Photo #:</p>	<ul style="list-style-type: none"> • Change hardware height • •
<p>3.11 Can the door be opened easily (5 pounds maximum force)? [404.2.9] Note: You can use a pressure gauge or fish scale to measure force. If you do not have one you will need to judge whether the door is easy to open.</p>	<p><input type="checkbox"/> Yes <input checked="" type="checkbox"/> No Measurement: 20 lbf</p>		<p>Photo #:</p>	<ul style="list-style-type: none"> • Adjust or replace closers • Install lighter doors • Install power-assisted or automatic door openers
<p>3.12 If the door has a closer, does it take at least 5 seconds to close from an open position of 90 degrees to a position of 12 degrees from the latch? [404.2.8.1]</p>	<p><input checked="" type="checkbox"/> Yes <input type="checkbox"/> No Measurement: 6 SEC.</p>		<p>Photo #:</p>	<ul style="list-style-type: none"> • Adjust closer • •

<p>3.13 If there are two doors in a series, e.g. vestibule, is the distance between the doors at least 48 inches plus the width of the doors when swinging into the space? [404.2.6]</p> <p><i>NA</i></p>	<p><input type="checkbox"/> Yes <input type="checkbox"/> No</p> <p>Measurement:</p> <p><i>NA</i></p>	<p>48" min</p> <p>or</p> <p>48" min</p> <p>or</p> <p>48" min</p>	<p>Photo #:</p>	<ul style="list-style-type: none"> • Remove inner door • Change door swing •
<p>3.14 If there is a privacy wall and the door swings out, is there at least 24 inches of maneuvering clearance beyond the door latch side and 42 inches to the privacy wall? [404.2.4]</p> <p><i>NA</i></p>	<p><input type="checkbox"/> Yes <input type="checkbox"/> No</p> <p>Measurement:</p> <p><i>NA</i></p>	<p>24" min</p> <p>48" min</p> <p>42" min</p> <p>privacy wall</p>	<p>Photo #:</p>	<ul style="list-style-type: none"> • Reconfigure space • •

NA

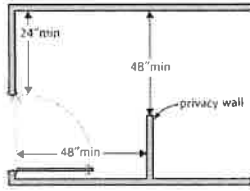
<p>3.15 If there is a privacy wall and the door swings in, is there at least 24 inches of maneuvering clearance beyond the door latch side and at least 48 inches to the privacy wall if there is no door closer or at least 54 inches if there is a door closer? [404.2.4]</p>	<p><input type="checkbox"/> Yes <input type="checkbox"/> No Measurement: NA</p>		<p>Photo #:</p>	<ul style="list-style-type: none"> • Reconfigure space • •
----------------------------------------------------------------------------------------------------------------------------------------------------------------------------------------------------------------------------------------------------------------------------------------	---------------------------------------------------------------------------------------------------------------------------	-----------------------------------------------------------------------------------	-----------------	---------------------------------------------------------------------------------------------

In the Toilet Room

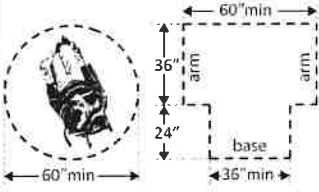
<p>3.16 Is there a clear path to at least one of each type of fixture, e.g. lavatory, hand dryer, etc., that is at least 36 inches wide? [403.5.1]</p>	<p><input checked="" type="checkbox"/> Yes <input type="checkbox"/> No Measurement: +36"</p>		<p>Photo #:</p>	<ul style="list-style-type: none"> • Remove obstructions • •
<p>3.17 Is there clear floor space available for a person in a wheelchair to turn around, i.e. a circle at least 60 inches in diameter or a T-shaped space within a 60-inch square? [603.2.1]</p>	<p><input checked="" type="checkbox"/> Yes <input type="checkbox"/> No Measurement: + 60"</p>		<p>Photo #:</p>	<ul style="list-style-type: none"> • Move or remove partitions, fixtures or objects such as trash cans • •

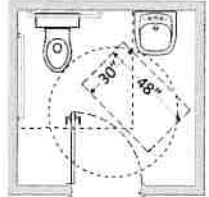
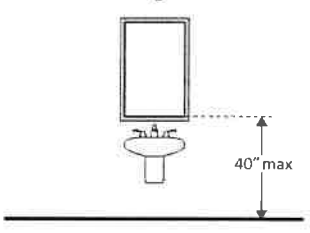
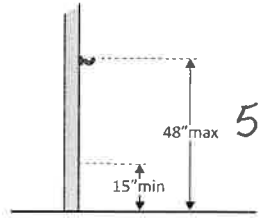
<p>3.18 In a single user toilet room if the door swings in and over a clear floor space at an accessible fixture, is there a clear floor space at least 30 x 48 inches beyond the swing of the door? [603.2.3 Exception 2]</p>	<p><input checked="" type="checkbox"/> Yes <input type="checkbox"/> No Measurement: +30" +48"</p>		<p>Photo #:</p>	<ul style="list-style-type: none"> • Reverse door swing • Alter toilet room •
<p>3.19 If the mirror is over a lavatory or countertop, is the bottom edge of the reflecting surface no higher than 40 inches above the floor? Or If the mirror is not over the lavatory or countertop, is the bottom edge of the reflecting surface no higher than 35 inches above the floor?*[603.3]</p>	<p><input checked="" type="checkbox"/> Yes <input type="checkbox"/> No Measurement: 40" <input type="checkbox"/> Yes <input type="checkbox"/> No Measurement:</p>		<p>Photo #:</p>	<ul style="list-style-type: none"> * If installed before 3/15/2012 and the bottom edge of the reflecting surface is no higher than 40 inches above the floor, lowering the mirror to 35 inches is not required • Lower the mirror • Add another mirror •
<p>3.20 If there is a coat hook, is it no less than 15 inches and no greater than 48 inches above the floor?*[603.4]</p>	<p><input type="checkbox"/> Yes <input type="checkbox"/> No Measurement: 55 1/2"</p>		<p>Photo #:</p>	<ul style="list-style-type: none"> • Adjust hook • Replace with or provide additional accessible hook • * If installed before 3/15/2010 and the clear floor space allows a parallel approach, the coat hook may be 54 inches above the floor.

Lavatories The 2010 Standards refer to sinks in toilet rooms as lavatories.

3.21 Does at least one lavatory have a clear floor space for a forward approach at least 30 inches wide and 48 inches long? [606.2]

Yes No

Measurement:
+ 48"
+ 30"

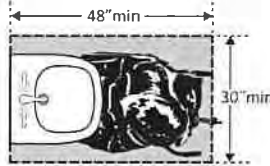

Photo #:

- Alter lavatory
- Replace lavatory
-

3.22 Do no less than 17 inches and no greater than 25 inches of the clear floor space extend under the lavatory so that a person using a wheelchair can get close enough to reach the faucet? [306.2]

Yes No

Measurement:
17"
+ 48"

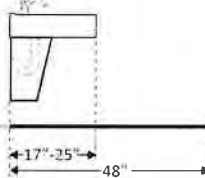

Photo #:

- Alter lavatory
- Replace lavatory
-

3.23 Is the front of the lavatory or counter surface, whichever is higher, no more than 34 inches above the floor? [606.3]

Yes No

Measurement:
34"

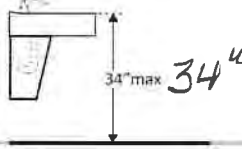

Photo #:

- Alter lavatory
- Replace lavatory
-

3.24 Is there at least 27 inches clearance from the floor to the bottom of the lavatory that extends at least 8 inches under the lavatory for knee clearance? [306.3.3]

Yes No

Measurement:
30"

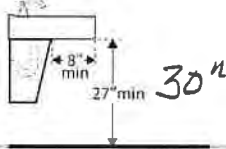
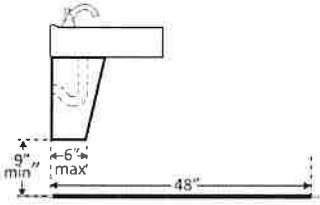
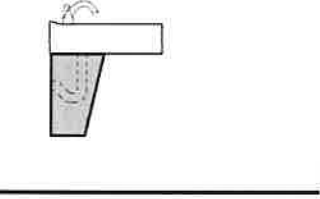
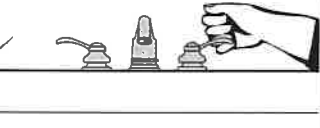

Photo #:

- Alter lavatory
- Replace lavatory
-

<p>3.25 Is there toe clearance at least 9 inches high? [306.3.3]</p> <p>Note: Space extending greater than 6 inches beyond the available toe clearance at 9 inches above the floor is not considered toe clearance.</p>	<p><input checked="" type="checkbox"/> Yes <input type="checkbox"/> No</p>		<p>Photo #:</p>	<ul style="list-style-type: none"> • Alter lavatory • Replace lavatory
<p>3.26 Are pipes below the lavatory insulated or otherwise configured to protect against contact? [606.5]</p>	<p><input checked="" type="checkbox"/> Yes <input type="checkbox"/> No</p>		<p>Photo #:</p>	<ul style="list-style-type: none"> • Install insulation • Install cover panel
<p>3.27 Can the faucet be operated without tight grasping, pinching, or twisting of the wrist?</p> <p>Is the force required to activate the faucet no greater than 5 pounds? [606.4]</p>	<p><input checked="" type="checkbox"/> Yes <input type="checkbox"/> No</p> <p><input type="checkbox"/> Yes <input checked="" type="checkbox"/> No</p>		<p>Photo #:</p>	<ul style="list-style-type: none"> • Adjust faucet • Replace faucet

Soap Dispensers and Hand Dryers

ADA Checklist for Existing Facilities

Priority 3 – Toilet Rooms

3.28 Are the operable parts of the soap dispenser within one of the following reach ranges:

Above lavatories or counters no less than 20 inches and no greater than 44 inches above the floor?
[308.2.2]

Yes No

Measurement:

42"

Above lavatories less than 20 inches deep: no higher than 48 inches above the floor?

Yes No

Measurement:

42"

Not over an obstruction: no higher than 48 inches above the floor?
[308.2]

Yes No

Measurement:

42"

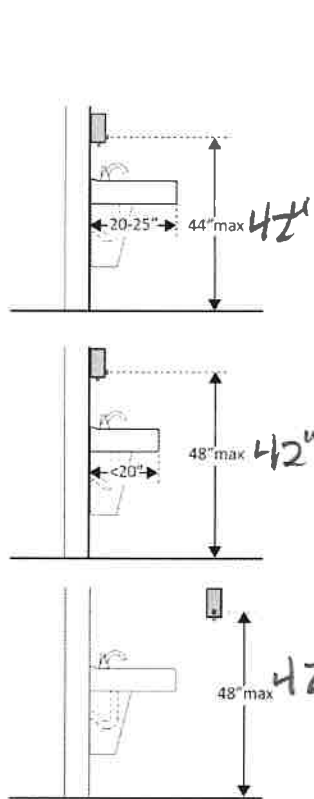

Photo #:

- Adjust dispensers
- Replace with or provide additional accessible dispensers
-

<p>3.29 Are the operable parts of the hand dryer or towel dispenser within one of the following reach ranges:</p> <p>Above lavatories or counters no less than 20 inches and no greater than 25 inches deep: no higher than 44 inches above the floor? <input type="checkbox"/> Yes <input type="checkbox"/> No</p> <p>Above lavatories less than 20 inches deep: no higher than 48 inches above the floor? <input type="checkbox"/> Yes <input type="checkbox"/> No</p> <p>Not over an obstruction: no higher than 48 inches above the floor? <input type="checkbox"/> Yes <input type="checkbox"/> No [308.2]</p> <p>Can the operable parts of the hand dryer or towel dispenser be operated without tight grasping, pinching or twisting of the wrist? <input type="checkbox"/> Yes <input type="checkbox"/> No</p> <p>Is the force required to activate the hand dryer or towel dispenser no greater than 5 pounds? <input type="checkbox"/> Yes <input type="checkbox"/> No [309.4]</p>	<p>Measurement: 44" max</p> <p>Measurement: 48" max</p> <p>Measurement: 48" max</p> <p>Measurement: 48"</p>		<p>Photo #:</p>	<ul style="list-style-type: none"> • Adjust dispensers • Replace with or provide additional accessible dispensers
-------------------------------------------------------------------------------------------------------------------------------------------------------------------------------------------------------------------------------------------------------------------------------------------------------------------------------------------------------------------------------------------------------------------------------------------------------------------------------------------------------------------------------------------------------------------------------------------------------------------------------------------------------------------------------------------------------------------------------------------------------------------------------------------------------------------------------------------------------------------------------------------------------------------------------------------------------------------------------------------------------------	-------------------------------------------------------------------------------------------------------------	--	-----------------	-------------------------------------------------------------------------------------------------------------------------------------------

Water Closets in Single-User Toilet Rooms and Compartments (Stalls) The 2010 Standards refer to toilets as water closets.

ADA Checklist for Existing Facilities

Priority 3 – Toilet Rooms





<p>3.30 Is the centerline of the water closet no less than 16 inches and no greater than 18 inches from the side wall or partition? [604.2]</p>	<p><input checked="" type="checkbox"/> Yes <input type="checkbox"/> No Measurement: 18"</p>	 <p>18"</p>	<p>Photo #:</p>	<ul style="list-style-type: none"> • Move toilet • Replace toilet • Move partition •
<p>3.31 Is clearance provided around the water closet measuring at least 60 inches from the side wall and at least 56 inches from the rear wall?*[604.3.1]</p> <p>?</p>	<p><input type="checkbox"/> Yes <input type="checkbox"/> No Measurement: NA</p>	 <p>54" 56" min</p> <p>60" min</p>	<p>Photo #:</p>	<p>* If constructed before 3/15/12, clearances around water closets in single user toilet rooms can be 48 inches wide by 66 inches long or 48 inches wide by 56 inches long (depending on the approach to the water closet, see 1991 Standards Figure 28) and the lavatory may overlap that clearance if the door to the room does not swing into the required clearances at fixtures (such as lavatories, water closet and urinals) and the edge of the lavatory is at least 18 inches from the centerline of the water closet</p> <ul style="list-style-type: none"> • Alter room/compartment for clearance • •

			Photo #:	
<p>3.32 Is the height of the water closet no less than 17 inches and no greater than 19 inches above the floor measured to the top of the seat? [604.4]</p>	<p><input checked="" type="checkbox"/> Yes <input type="checkbox"/> No Measurement: 18"</p>		Photo #:	<ul style="list-style-type: none"> • Adjust toilet height • Replace toilet •
<p>3.33 Is there a grab bar at least 42 inches long on the side wall?</p> <p>Is it located no more than 12 inches from the rear wall?</p> <p>Does it extend at least 54 inches from the rear wall? [604.5.1]</p> <p>Is it mounted no less than 33 inches and no greater than 36 inches above the floor to the top of the gripping surface? [609.4]</p> <p>Is there at least 12 inches clearance between the grab bar</p>	<p><input checked="" type="checkbox"/> Yes <input type="checkbox"/> No Measurement: 42"</p> <p><input type="checkbox"/> Yes <input checked="" type="checkbox"/> No Measurement: 12"</p> <p><input checked="" type="checkbox"/> Yes <input type="checkbox"/> No Measurement: 54"</p> <p><input checked="" type="checkbox"/> Yes <input type="checkbox"/> No Measurement: 36"</p> <p><input type="checkbox"/> Yes <input type="checkbox"/> No</p>		Photo #:	<ul style="list-style-type: none"> • Install grab bar • Relocate grab bar • Relocate objects •

<p>and protruding objects above?*</p> <p>Is there at least 1½ inches clearance between the grab bar and projecting objects below?*</p> <p>Is the space between the wall and the grab bar 1 ½ inches? [609.3]</p>	<p>Measurement:</p> <p><input type="checkbox"/> Yes <input type="checkbox"/> No</p> <p>Measurement:</p> <p><input type="checkbox"/> Yes <input type="checkbox"/> No</p> <p>Measurement:</p> <p><input type="checkbox"/> Yes <input type="checkbox"/> No</p>		<p>Photo #:</p>	<p>* If constructed before 3/15/2012 grab bars do not need to be relocated; there are no space requirements above and below grab bars in the 1991 Standards</p>
<p>3.34 Is there a grab bar at least 36 inches long on the rear wall?</p> <p>Does it extend at least 12 inches from the centerline of the water closet on one side (side wall)?</p> <p>Does it extend at least 24 inches on the other (open) side? [604.5.2]</p> <p>Is it mounted no less than 33 inches and no greater than 36 inches above the floor to the top of the gripping surface? [609.4]</p> <p>Are there at least 12 inches clearance between the grab bar and protruding objects above?*</p> <p>Are there at least 1½ inches</p>	<p><input checked="" type="checkbox"/> Yes <input type="checkbox"/> No</p> <p>Measurement: 36"</p> <p><input type="checkbox"/> Yes <input type="checkbox"/> No</p> <p>Measurement: 12"</p> <p><input checked="" type="checkbox"/> Yes <input type="checkbox"/> No</p> <p>Measurement: 24"</p> <p><input checked="" type="checkbox"/> Yes <input type="checkbox"/> No</p> <p>Measurement: 37"</p> <p><input type="checkbox"/> Yes <input type="checkbox"/> No</p> <p>Measurement: H</p> <p><input type="checkbox"/> Yes <input type="checkbox"/> No</p>		<p>Photo #:</p>	<ul style="list-style-type: none"> • Install grab bar • Relocate grab bar • Relocate objects • <p>* If constructed before 3/15/2012 grab bars do not need to be relocated; there are no space</p>

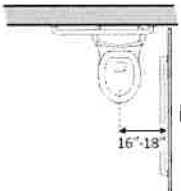
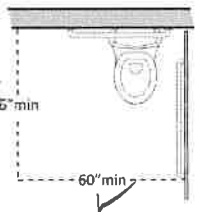
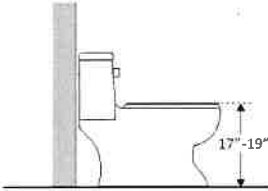
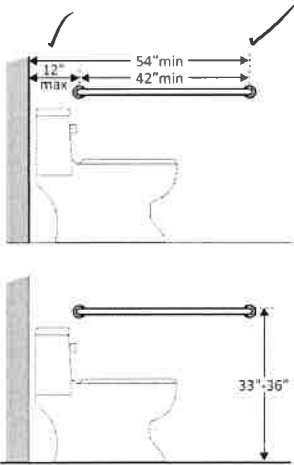
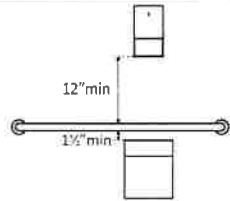
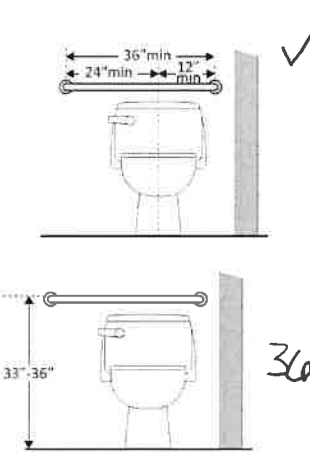
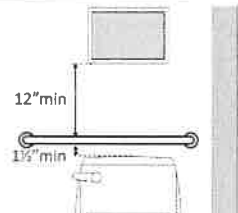

<p>clearance between the grab bar and projecting objects below?*</p> <p>Is the space between the wall and the grab bar 1½ inches? [609.3]</p>	<p>Measurement: 15" <input checked="" type="checkbox"/> Yes <input type="checkbox"/> No Measurement: 1½" <input checked="" type="checkbox"/> Yes <input type="checkbox"/> No</p>		<p>Photo #:</p>	<p>requirements above and below grab bars in the 1991 Standards</p>
<p>3.35 If the flush control is hand operated, is the operable part located no higher than 48 inches above the floor? [604.6]</p>	<p><input type="checkbox"/> Yes <input type="checkbox"/> No Measurement: 27"</p>		<p>Photo #:</p>	<ul style="list-style-type: none"> • Move control • Install sensor with override button no higher than 48 inches
<p>3.36 If the flush control is hand operated, can it be operated with one hand and without tight grasping, pinching, or twisting of the wrist?</p> <p>Is the force required to activate the flush control no greater than 5 pounds? [605.4]</p>	<p><input type="checkbox"/> Yes <input type="checkbox"/> No <input checked="" type="checkbox"/> Yes <input type="checkbox"/> No Measurement: 12 lbs</p>		<p>Photo #:</p>	<ul style="list-style-type: none"> • Change control • Adjust control
<p>3.37 Is the flush control on the open side of the water closet? [604.6]</p>	<p><input checked="" type="checkbox"/> Yes <input type="checkbox"/> No</p>		<p>Photo #:</p>	<ul style="list-style-type: none"> • Move control

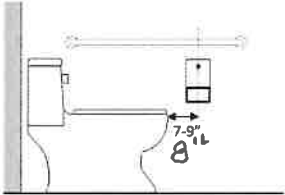
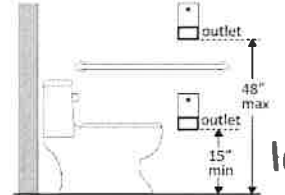
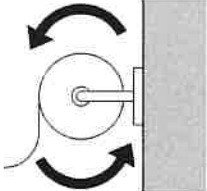

<p>3.38 Is the toilet paper dispenser located no less than 7 inches and no greater than 9 inches from the front of the water closet to the centerline of the dispenser?*</p> <p>[604.7]</p>	<p><input checked="" type="checkbox"/> Yes <input type="checkbox"/> No</p> <p>Measurement: 8" ¹¹</p>		<p>Photo #:</p>	<p>* If constructed before 3/15/2012 dispenser does not need to be relocated if it is within reach from the water closet seat; the 1991 Standards do not specify distance from the front of the water closet</p> <ul style="list-style-type: none"> • Relocate dispenser • •
<p>3.39 Is the outlet of the dispenser:</p> <p>Located no less than 15 inches and no greater than 48 inches above the floor?</p> <p>Not located behind grab bars?</p> <p>[604.7]</p>	<p><input checked="" type="checkbox"/> Yes <input type="checkbox"/> No</p> <p>Measurement: 16" ¹¹</p> <p><input type="checkbox"/> Yes <input type="checkbox"/> No</p>		<p>Photo #:</p>	<ul style="list-style-type: none"> • Relocate dispenser • •
<p>3.40 Does the dispenser allow continuous paper flow?</p> <p>[604.7]</p>	<p><input checked="" type="checkbox"/> Yes <input type="checkbox"/> No</p>		<p>Photo #:</p>	<ul style="list-style-type: none"> • Adjust dispenser • Replace dispenser •

Toilet Compartments (Stalls)

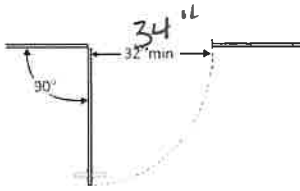
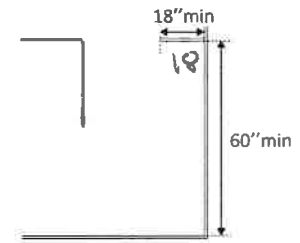
ADA Checklist for Existing Facilities

Priority 3 – Toilet Rooms

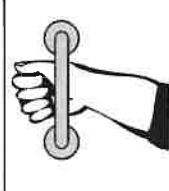
<p>3.41 Is the door opening width at least 32 inches clear, between the face of the door and the stop, when the door is open 90 degrees? [604.8.1.2]</p>	<p><input checked="" type="checkbox"/> Yes <input type="checkbox"/> No Measurement: 34"</p>		<p>Photo #:</p>	<ul style="list-style-type: none"> • Widen door width • •
<p>3.42 If there is a front approach to the pull side of the door, is there at least 18 inches of maneuvering clearance beyond the latch side plus 60 inches clear depth? [604.8.1.2]</p> <p>Note: See 2010 Standards 604.8.1.2 Doors for maneuvering clearance requirements on the push side of the door and side approaches to the pull side of the door</p>	<p><input type="checkbox"/> Yes <input type="checkbox"/> No Measurement:</p>		<p>Photo #:</p>	<ul style="list-style-type: none"> • Remove obstructions • •
<p>3.43 Is the door self-closing? [604.8.1.2]</p>	<p><input checked="" type="checkbox"/> Yes <input type="checkbox"/> No</p>		<p>Photo #:</p>	<ul style="list-style-type: none"> • Add closer • Replace door •

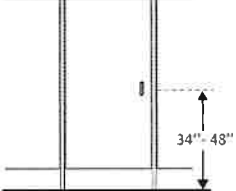
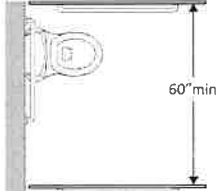
<p>3.44 Are there door pulls on both sides of the door that are operable with one hand and do not require tight grasping pinching or twisting of the wrist?*</p> <p>[604.8.1.2]</p>	<p><input checked="" type="checkbox"/> Yes <input type="checkbox"/> No</p>		<p>Photo #:</p>	<p>* If constructed before 3/15/2012 door pulls do not need to be added; door pulls are not required in the 1991 Standards</p> <ul style="list-style-type: none"> • Replace hardware • •
<p>3.45 Is the lock operable with one hand and without tight grasping, pinching or twisting of the wrist?</p> <p>[309.4]</p>	<p><input checked="" type="checkbox"/> Yes <input type="checkbox"/> No</p>		<p>Photo #:</p>	<ul style="list-style-type: none"> • Replace lock • •
<p>3.46 Are the operable parts of the door hardware mounted no less than 34 inches and no greater than 48 inches above the floor?</p> <p>[404.2.7]</p>	<p><input checked="" type="checkbox"/> Yes <input type="checkbox"/> No</p> <p>Measurement: 36"</p>		<p>Photo #:</p>	<ul style="list-style-type: none"> • Relocate hardware • •
<p>3.47 Is the compartment at least 60 inches wide?</p> <p>[604.8.1.1]</p>	<p><input checked="" type="checkbox"/> Yes <input type="checkbox"/> No</p> <p>Measurement: + 60"</p>		<p>Photo #:</p>	<ul style="list-style-type: none"> • Widen compartment • •

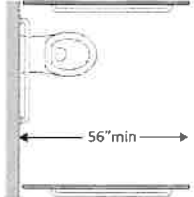
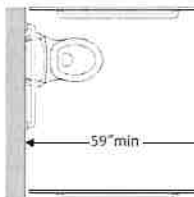
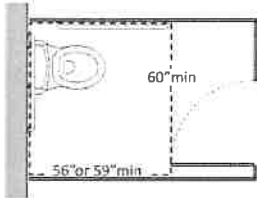
<p>3.48 If the water closet is wall hung, is the compartment at least 56 inches deep? [604.8.1.1]</p>	<p><input type="checkbox"/> Yes <input type="checkbox"/> No Measurement:</p>		<p>Photo #:</p>	<ul style="list-style-type: none"> • Widen compartment • •
<p>3.49 If the water closet is floor mounted, is the compartment at least 59 inches deep? [604.8.1.1]</p>	<p><input checked="" type="checkbox"/> Yes <input type="checkbox"/> No Measurement: 60"</p>		<p>Photo #:</p>	<ul style="list-style-type: none"> • Alter compartment • •
<p>3.50 If the door swings in, is the minimum required compartment area provided beyond the swing of the door (60 inches x 56 inches if water closet is wall hung or 59 inches if water closet is floor mounted)? [604.8.1.1]</p>	<p><input type="checkbox"/> Yes <input type="checkbox"/> No Measurement: N/A</p>		<p>SWINGS OUT</p> <p>Photo #:</p>	<ul style="list-style-type: none"> • Reverse door swing • Alter compartment •

ADA Checklist for Existing Facilities

Priority 4 – Additional Access

Based on the 2010 ADA Standards for Accessible Design

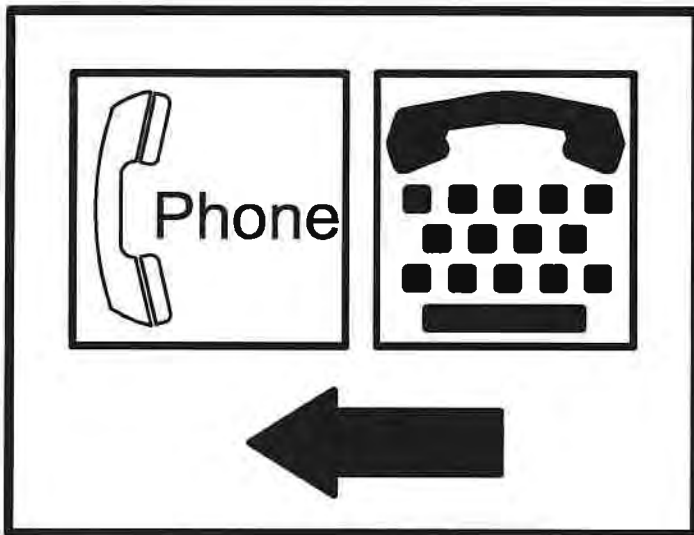

Project _____

Building _____

Location _____

Date _____

Surveyors _____

Contact Information _____

Amenities such as drinking fountains and public telephones should be accessible to people with disabilities.



Institute for Human Centered Design
www.HumanCenteredDesign.org
Copyright © 2016



ADA National Network
Questions on the ADA 800-949-4232 voice/tty
www.ADAchecklist.org



This checklist was produced by the New England ADA Center, a project of the Institute for Human Centered Design and a member of the ADA National Network. This checklist was developed under a grant from the Department of Education, NIDRR grant number H133A060092-09A. However the contents do not necessarily represent the policy of the Department of Education, and you should not assume endorsement by the Federal Government.

Questions or comments on the checklist contact the New England ADA Center at 617-695-0085 voice/tty or ADAinfo@NewEnglandADA.org

For the full set of checklists, including the checklists for recreation facilities visit www.ADAchecklist.org.

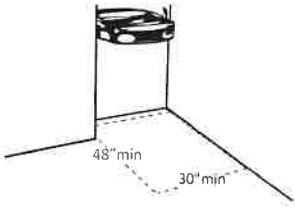
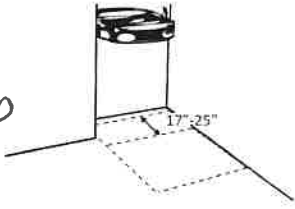
Copyright © 2016 ADA Checklist for Existing Materials. You can freely reproduce and distribute this content. Include proper attribution. But you must get permission before using this content as a fee-based product.

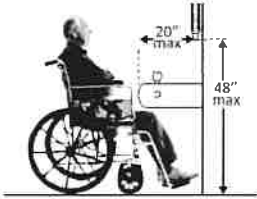
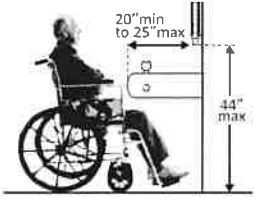
Priority 4 – Additional Access		Comments	Possible Solutions
Drinking Fountains			
<p>4.1 Does at least one drinking fountain have a clear floor space at least 30 inches wide x at least 48 inches long centered in front of it for a forward approach?*</p> <p>[See 2010 ADA Standards for Accessible Design – 602.2]</p>	<p><input checked="" type="checkbox"/> Yes <input type="checkbox"/> No</p> <p>Measurement:</p> <p>+48"^l +30"^w</p>		<p>Photo #:</p> <p>*If installed before 3/15/2012, a parallel approach is permitted and the clear floor space is not required to be centered</p> <ul style="list-style-type: none"> • Alter space • Relocate drinking fountain • Install a drinking fountain in another location
<p>4.2 If there is a forward approach, do no less than 17 inches and no greater than 25 inches of the clear floor space extend under the drinking fountain?</p> <p>[306.2.2, 306.2.3]</p> <p>Note: If the drinking fountain is primarily for children's use and the spout is no more than 30 inches above the floor and no more than 3 ½ inches from the edge of the unit, a parallel approach is permitted.</p>	<p><input type="checkbox"/> Yes <input type="checkbox"/> No</p> <p>Measurement:</p> <p>RECESSED FLUSH</p>		<p>Photo #:</p> <ul style="list-style-type: none"> • Alter space • Replace drinking fountain •

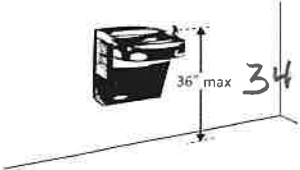

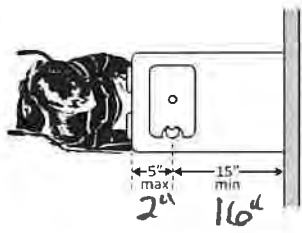
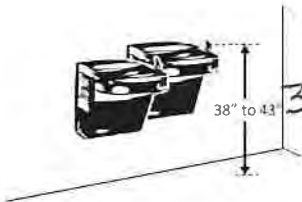
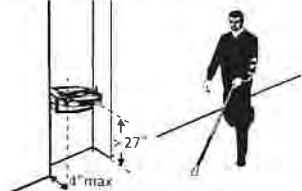

<p>4.3 If the drinking fountain is no deeper than 20 inches, are the operable parts no higher than 48 inches above the floor? [308.2.2]</p>	<p><input type="checkbox"/> Yes <input type="checkbox"/> No Measurement:</p>		<p>Photo #:</p>	<ul style="list-style-type: none"> • Adjust drinking fountain • Replace drinking fountain •
<p>4.4 If the drinking fountain is no less than 20 inches and no greater than 25 inches deep, are the operable parts no higher than 44 inches above the floor? [308.2.2]</p>	<p><input type="checkbox"/> Yes <input type="checkbox"/> No Measurement:</p>		<p>Photo #:</p>	<ul style="list-style-type: none"> • Adjust drinking fountain • Replace drinking fountain •
<p>4.5 Can the control be operated with one hand and without tight grasping, pinching or twisting of the wrist? Is the force required to activate the control no more than 5 pounds? [309.4]</p>	<p><input type="checkbox"/> Yes <input type="checkbox"/> No <input type="checkbox"/> Yes <input type="checkbox"/> No Measurement:</p>		<p>Photo #:</p>	<ul style="list-style-type: none"> • Change control • Adjust control •
<p>4.6 Is the spout outlet no higher than 36 inches above the floor? [602.4]</p>	<p><input type="checkbox"/> Yes <input type="checkbox"/> No Measurement:</p>		<p>Photo #:</p>	<ul style="list-style-type: none"> • Adjust drinking fountain • Replace drinking fountain •



<p>4.7 Is the spout:</p> <p>At least 15 inches from the rear of the drinking fountain?</p> <p><input checked="" type="checkbox"/> Yes <input type="checkbox"/> No</p> <p>Measurement: 16"</p> <p>No more than 5 inches from the front of the drinking fountain? [602.5]</p> <p><input checked="" type="checkbox"/> Yes <input type="checkbox"/> No</p> <p>Measurement: 2"</p>	<p><input checked="" type="checkbox"/> Yes <input type="checkbox"/> No</p> <p>Measurement: 16"</p> <p><input checked="" type="checkbox"/> Yes <input type="checkbox"/> No</p> <p>Measurement: 2"</p>		<p>Photo #:</p>	<ul style="list-style-type: none"> • Adjust spout • Replace drinking fountain •
<p>4.8 If there is more than one drinking fountain, is there at least one for standing persons? [211.2]</p> <p>Is the spout outlet no lower than 38 inches and no higher than 43 inches above the floor? [602.7]</p>	<p><input checked="" type="checkbox"/> Yes <input type="checkbox"/> No</p> <p><input checked="" type="checkbox"/> Yes <input type="checkbox"/> No</p> <p>Measurement: 39"</p>		<p>Photo #:</p>	<ul style="list-style-type: none"> • Adjust drinking fountain • Install new drinking fountain for standing height •
<p>4.9 If the leading (bottom) edge of the fountain is higher than 27 inches above the floor, does the front of the fountain protrude no more than 4 inches into the circulation path? [307.2]</p>	<p><input checked="" type="checkbox"/> Yes <input type="checkbox"/> No</p> <p>Measurement: 27"</p>		<p>Photo #:</p>	<ul style="list-style-type: none"> • Adjust drinking fountain • Replace drinking fountain • Add tactile warning such as permanent planter or partial walls

NA

Public Telephones					
<p>4.10 Does at least one telephone have a clear floor space at least 30 inches wide x at least 48 inches long for a parallel or forward approach? [704.2.1]</p>	<p><input type="checkbox"/> Yes <input type="checkbox"/> No</p>	<p>NA</p>		<p>Photo #:</p>	<ul style="list-style-type: none"> • Move telephone • Install new telephone for clear floor space •
<p>4.11 Is the highest operable part of the telephone no higher than 48 inches above the floor? [704.2.2]</p>	<p><input type="checkbox"/> Yes <input type="checkbox"/> No</p>	<p>Measurement: NA</p>		<p>Photo #:</p>	<ul style="list-style-type: none"> • Adjust telephone • •
<p>4.12 If the leading (bottom) edge of the telephone is higher than 27 inches above the floor, does the front of the telephone protrude no more than 4 inches into the circulation path? [307.2]</p>	<p><input type="checkbox"/> Yes <input type="checkbox"/> No</p>	<p>Measurement: NA</p>		<p>Photo #:</p>	<ul style="list-style-type: none"> • Adjust telephone • •

NA

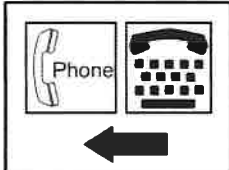
<p>4.13 Does at least one telephone have a volume control? [704.3]</p>	<p><input type="checkbox"/> Yes <input type="checkbox"/> No</p> <p>NA</p>		<p>Photo #:</p>	<ul style="list-style-type: none"> • Install volume control • Replace telephone with one that has volume control
<p>4.14 Is the volume control identified by a pictogram of a telephone handset with radiating sound waves? [703.7.2.3]</p>	<p><input type="checkbox"/> Yes <input type="checkbox"/> No</p> <p>NA</p>		<p>Photo #:</p>	<ul style="list-style-type: none"> • Add pictogram
<p>4.15 Does at least one telephone have a TTY? [217.4.1]</p> <p>Note: TTY's are devices that employ interactive text-based communication through the transmission of coded signals across the telephone network. They are mainly used by people who are deaf and/or cannot speak.</p>	<p><input type="checkbox"/> Yes <input type="checkbox"/> No</p> <p>NA</p>		<p>Photo #:</p>	<ul style="list-style-type: none"> • Install TTY
<p>4.16 Is the touch surface of the TTY keypad at least 34 inches above the floor? [704.4.1]</p> <p>Note: If a seat is provided, the TTY is not required to be 34 inches minimum above the floor.</p>	<p><input type="checkbox"/> Yes <input type="checkbox"/> No</p> <p>Measurement:</p> <p>NA</p>		<p>Photo #:</p>	<ul style="list-style-type: none"> • Adjust height of TTY

<p>4.17 Is the TTY identified by the International Symbol of TTY? [703.7.2.2]</p> <p>NA</p>	<p><input type="checkbox"/> Yes <input type="checkbox"/> No</p> <p>NA</p>		<p>Photo #:</p>	<ul style="list-style-type: none"> • Add symbol • •
<p>4.18 Do signs that provide direction to public telephones also provide direction to the TTY? [216.9.2]</p> <p>NA</p>	<p><input type="checkbox"/> Yes <input type="checkbox"/> No</p> <p>NA</p>		<p>Photo #:</p>	<ul style="list-style-type: none"> • Add signs • •
<p>4.19 Do telephones that do not have a TTY provide direction to the TTY? [216.9.2]</p> <p>NA</p>	<p><input type="checkbox"/> Yes <input type="checkbox"/> No</p> <p>NA</p>		<p>Photo #:</p>	<ul style="list-style-type: none"> • Add signs • •
<p>Fire Alarm Systems</p>				
<p>4.20 If there are fire alarm systems, do they have both flashing lights and audible signals? [702.1]</p>	<p><input checked="" type="checkbox"/> Yes <input type="checkbox"/> No</p>		<p>Photo #:</p>	<ul style="list-style-type: none"> • Install audible and visual alarms • •



TOWN OF WEAVERVILLE

APPENDIX C.2:

Fire Department

ADA TRANSITION PLAN

ADA Checklist for Existing Facilities

Priority 1 – Approach & Entrance

Based on the 2010 ADA Standards for Accessible Design

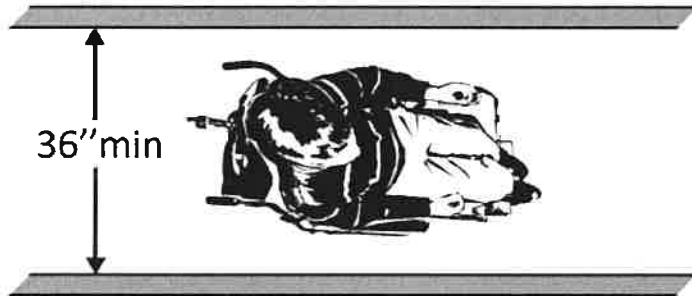

Project ADA TRANSITION PLAN

Building FIRE DEPARTMENT

Location WEAVERVILLE H.C.

Date 4-20-2020

Surveyors ANN F. MACKAY

Contact Information KYLE DAVIS

An accessible route from site arrival points and an accessible entrance should be provided for everyone.



Institute for Human Centered Design
www.HumanCenteredDesign.org
Copyright © 2016



ADA National Network
Questions on the ADA 800-949-4232 voice/tty
www.ADAchecklist.org

This checklist was produced by the New England ADA Center, a project of the Institute for Human Centered Design and a member of the ADA National Network. This checklist was developed under a grant from the Department of Education, NIDRR grant number H133A060092-09A. However the contents do not necessarily represent the policy of the Department of Education, and you should not assume endorsement by the Federal Government.

Questions or comments on the checklist contact the New England ADA Center at 617-695-0085 voice/tty or ADAinfo@NewEnglandADA.org



For the full set of checklists, including the checklists for recreation facilities visit www.ADAchecklist.org.

Copyright © 2016 ADA Checklist for Existing Materials. You can freely reproduce and distribute this content. Include proper attribution. But you must get permission before using this content as a fee-based product.

Priority 1 – Approach & Entrance		Comments	Possible Solutions												
<p>1.1 Is there at least one route from site arrival points (parking, passenger loading zones, public sidewalks and public transportation stops) that does not require the use of stairs? [See 2010 ADA Standards for Accessible Design – 206.2.1]</p>	<p><input checked="" type="checkbox"/> Yes <input type="checkbox"/> No</p> <p>If yes, location of route:</p>	<p>Photo #:</p>	<ul style="list-style-type: none"> • Add a ramp • Regrade to 1:20 maximum slope • Add a lift if site constraints prevent other solutions 												
<p>Parking Accessible parking spaces should be identified by size, access aisle and signage.</p>															
<p>1.2 If parking is provided for the public, are an adequate number of accessible spaces provided? [208.2]</p>	<p><input checked="" type="checkbox"/> Yes <input type="checkbox"/> No</p> <p>Total #: 3</p> <p>Accessible #: 2</p>	<table border="1"> <thead> <tr> <th>Total Spaces</th> <th>Accessible Spaces</th> </tr> </thead> <tbody> <tr> <td>1 - 25</td> <td>1</td> </tr> <tr> <td>26 - 50</td> <td>2</td> </tr> <tr> <td>51 - 75</td> <td>3</td> </tr> <tr> <td>76 - 100</td> <td>4</td> </tr> <tr> <td colspan="2">100+ see 2010 Standards 208.2</td> </tr> </tbody> </table> <p>Photo #:</p>	Total Spaces	Accessible Spaces	1 - 25	1	26 - 50	2	51 - 75	3	76 - 100	4	100+ see 2010 Standards 208.2		<ul style="list-style-type: none"> • Reconfigure by repainting lines • •
Total Spaces	Accessible Spaces														
1 - 25	1														
26 - 50	2														
51 - 75	3														
76 - 100	4														
100+ see 2010 Standards 208.2															
<p>1.3 Of the accessible spaces, is at least one a van accessible space?*[208.2.4]</p>	<p><input checked="" type="checkbox"/> Yes <input type="checkbox"/> No</p>	<p>*For every 6 or fraction of 6 parking spaces required by the table above, at least 1 should be a van accessible space.</p> <p>Photo #:</p>	<ul style="list-style-type: none"> • If constructed before 3/15/2012, parking is compliant if at least 1 in every 8 accessible spaces is van accessible • Reconfigure by repainting lines 												

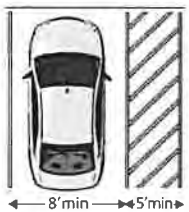
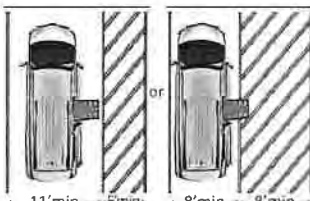

ADA Checklist for Existing Facilities

Priority 1 – Approach & Entrance

<p>1.4 Are accessible spaces at least 8 feet wide with an access aisle at least 5 feet wide? [502.2, 502.3]</p> <p>Note: Two spaces may share an access aisle. Check state/local requirements; some specify that each space have its own aisle.</p>	<p><input checked="" type="checkbox"/> Yes <input type="checkbox"/> No</p> <p>Measurement: 8' 8' 3"</p>	 <p>← 8' min → ← 5' min →</p>	<p>Photo #:</p> <ul style="list-style-type: none"> • Reconfigure by repainting lines • •
<p>1.5 Is the van accessible space: At least 11 feet wide with an access aisle at least 5 feet wide? Or At least 8 feet wide with an access aisle at least 8 feet wide? [502.2]</p>	<p><input type="checkbox"/> Yes <input type="checkbox"/> No</p> <p>Measurement: NA</p> <p><input type="checkbox"/> Yes <input type="checkbox"/> No</p> <p>Measurement: 8' x 8'</p>	 <p>← 11' min → ← 5' min → or ← 8' min → ← 8' min →</p>	<p>Photo #:</p> <ul style="list-style-type: none"> • Reconfigure to provide van-accessible space(s) • •
<p>1.6 Is at least 98 inches of vertical clearance provided for the van accessible space? [502.5]</p>	<p><input type="checkbox"/> Yes <input type="checkbox"/> No</p> <p>Measurement: NA</p>	 <p>98" min</p>	<p>Photo #:</p> <ul style="list-style-type: none"> • Reconfigure to provide van-accessible space(s) • •

ADA Checklist for Existing Facilities

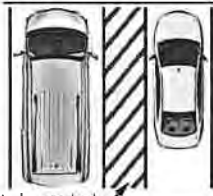
Priority 1 – Approach & Entrance

<p>1.7 Are the access aisles marked so as to discourage parking in them? [502.3.3]</p> <p>Note: The marking method and color may be addressed by state/local requirements.</p>	<p><input checked="" type="checkbox"/> Yes <input type="checkbox"/> No</p>		<p>Photo #:</p>	<ul style="list-style-type: none"> • Mark access aisles • •
<p>1.8 Is the slope of the accessible parking spaces and access aisles no steeper than 1:48 in all directions? [502.4]</p>	<p><input checked="" type="checkbox"/> Yes <input type="checkbox"/> No</p> <p>Measurement: 1" = 48"</p>		<p>Photo #:</p>	<ul style="list-style-type: none"> • Regrade surface • •
<p>1.9 Do the access aisles adjoin an accessible route? [502.3]</p>	<p><input checked="" type="checkbox"/> Yes <input type="checkbox"/> No</p>		<p>Photo #:</p>	<ul style="list-style-type: none"> • Create accessible route • Relocate accessible space •
<p>1.10 Are accessible spaces identified with a sign that includes the International Symbol of Accessibility? Is the bottom of the sign at least 60 inches above the ground? [502.6]</p> <p>Note: The International Symbol of Accessibility is not required on the ground.</p>	<p><input checked="" type="checkbox"/> Yes <input type="checkbox"/> No</p> <p><input checked="" type="checkbox"/> Yes <input type="checkbox"/> No</p> <p>Measurement: 51"</p>		<p>Photo #:</p>	<ul style="list-style-type: none"> • Install signs • •

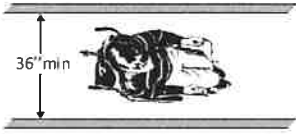
<p>1.11 Are there signs reading “van accessible” at van accessible spaces? [502.6]</p>	<p><input checked="" type="checkbox"/> Yes <input type="checkbox"/> No</p>		<p>Photo #:</p>	<ul style="list-style-type: none"> • Install signs • •
<p>1.12 Of the total parking spaces, are the accessible spaces located on the closest accessible route to the accessible entrance(s)? [208.3.1]</p> <p>Note: If parking serves multiple entrances, accessible parking should be dispersed.</p>	<p><input checked="" type="checkbox"/> Yes <input type="checkbox"/> No</p>	<p>Photo #:</p>	<p>Photo #:</p>	<ul style="list-style-type: none"> • Reconfigure spaces • •
<p>Exterior Accessible Route</p>				
<p>1.13 Is the route stable, firm and slip-resistant? [302.1]</p>	<p><input checked="" type="checkbox"/> Yes <input type="checkbox"/> No</p>	<p>Photo #:</p>	<p>Photo #:</p>	<ul style="list-style-type: none"> • Repair uneven paving • Fill small bumps and breaks with patches • Replace gravel with asphalt or other surface
<p>1.14 Is the route at least 36 inches wide? [403.5.1]</p>	<p><input checked="" type="checkbox"/> Yes <input type="checkbox"/> No</p> <p>Measurement: 72"</p>		<p>Photo #:</p>	<ul style="list-style-type: none"> • Change or move landscaping, furnishings or other items • Widen route •

<p>Note: The accessible route can narrow to 32 inches min. for a max. of 24 inches. These narrower portions of the route must be at least 48 inches from each other.</p>	<p>NA</p>		<p>Photo #:</p>	
<p>1.15 If the route is greater than 200 feet in length and less than 60 inches wide, is there a passing space no less than 60 x 60 inches? [403.5.3]</p>	<p><input type="checkbox"/> Yes <input type="checkbox"/> No Measurement: NA</p>		<p>Photo #:</p>	<ul style="list-style-type: none"> • Widen route for passing space • •
<p>1.16 If there are grates or openings on the route, are the openings no larger than 1/2 inches? Is the long dimension perpendicular to the dominant direction of travel? [302.3]</p>	<p><input type="checkbox"/> Yes <input type="checkbox"/> No Measurement: NA <input type="checkbox"/> Yes <input type="checkbox"/> No NA</p>		<p>Photo #:</p>	<ul style="list-style-type: none"> • Replace or move grate • •
<p>1.17 Is the running slope no steeper than 1:20, i.e. for every inch of height change there are at least 20 inches of route run? [403.3] Note: If the running slope is steeper than 1:20, treat as a ramp and add features such as edge protection and handrails.</p>	<p><input checked="" type="checkbox"/> Yes <input type="checkbox"/> No Measurement: 1" : 12"</p>		<p>Photo #:</p>	<ul style="list-style-type: none"> • Regrade to 1:20 max. • •

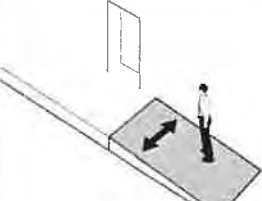
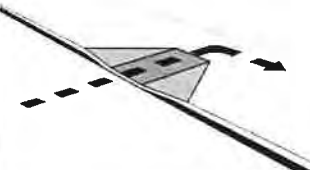
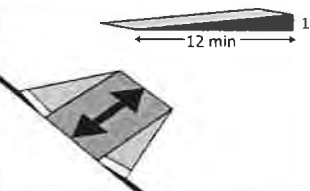
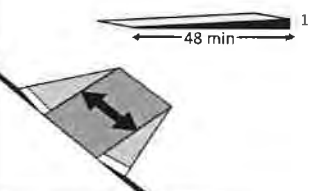
<p>1.18 Is the cross slope no steeper than 1:48? [403.3]</p>	<p><input type="checkbox"/> Yes <input type="checkbox"/> No</p> <p>Measurement: 1" : 12"</p>		<p>Photo #:</p>	<ul style="list-style-type: none"> • Regrade to 1:48 max. • •
<p>Curb Ramps</p>				
<p>1.19 If the accessible route crosses a curb, is there a curb ramp? [402.2]</p>	<p><input checked="" type="checkbox"/> Yes <input type="checkbox"/> No</p>		<p>Photo #:</p>	<ul style="list-style-type: none"> • Install curb ramp • •
<p>1.20 Is the running slope of the curb ramp no steeper than 1:12, i.e. for every inch of height change there are at least 12 inches of curb ramp run? [406.1, 405.2]</p>	<p><input type="checkbox"/> Yes <input type="checkbox"/> No</p> <p>Measurement: 1" : 12"</p>		<p>Photo #:</p>	<ul style="list-style-type: none"> • Regrade curb ramp • •
<p>1.21 Is the cross slope of the curb ramp, excluding flares, no steeper than 1:48? [406.1, 405.3]</p>	<p><input type="checkbox"/> Yes <input type="checkbox"/> No</p> <p>Measurement: 2" : 12"</p>		<p>Photo #:</p>	<ul style="list-style-type: none"> • Regrade curb ramp • •

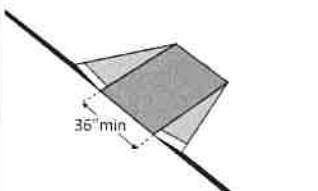
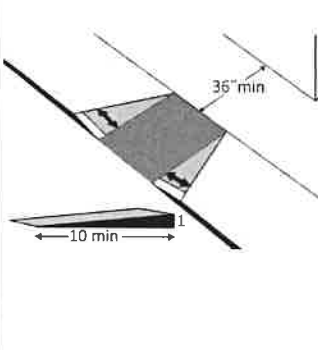
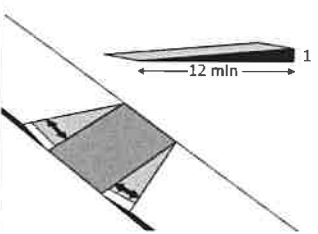

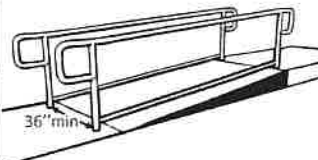
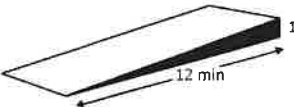
<p>1.22 Is the curb ramp, excluding flares, at least 36 inches wide? [406.1, 405.5]</p>	<p><input checked="" type="checkbox"/> Yes <input type="checkbox"/> No Measurement: 72"</p>	 <p>A diagram showing a curb ramp with a flare. A dimension line indicates the flare is at least 36 inches wide.</p>	<p>Photo #:</p>	<ul style="list-style-type: none"> • Widen curb ramp • •
<p>1.23 At the top of the curb ramp is there a level landing (slope no steeper than 1:48 in all directions) that is at least 36 inches long and at least as wide as the curb ramp? [406.4]</p> <p>If there are curb ramp flares, are the slopes of the flares no steeper than 1:10, i.e. for every inch of height change there are at least 10 inches of flare run? [406.3]</p>	<p><input checked="" type="checkbox"/> Yes <input type="checkbox"/> No Measurement: 72" x 72"</p> <p><input type="checkbox"/> Yes <input type="checkbox"/> No Measurement:</p>	 <p>A diagram showing a curb ramp with a level landing at the top. The landing is 36 inches long. A flare is shown with a 1:10 slope, where 10 inches of flare run corresponds to 1 inch of height change.</p>	<p>Photo #:</p>	<ul style="list-style-type: none"> • Reconfigure • Add ramp flares •
<p>1.24 If the landing at the top is less than 36 inches long, are there curb ramp flares? Are the slopes of the flares no greater than 1:12, i.e. for every inch of height change there are at least 12 inches of flare run? [406.4]</p>	<p><input type="checkbox"/> Yes <input type="checkbox"/> No NA</p> <p><input type="checkbox"/> Yes <input type="checkbox"/> No Measurement: NA</p>	 <p>A diagram showing a curb ramp with a flare. A dimension line indicates the flare has a 1:12 slope, where 12 inches of flare run corresponds to 1 inch of height change.</p>	<p>Photo #:</p>	<ul style="list-style-type: none"> • Add ramp flares • Regrade flares •

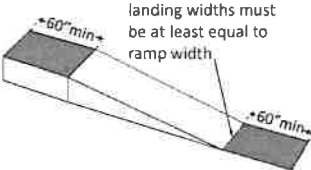
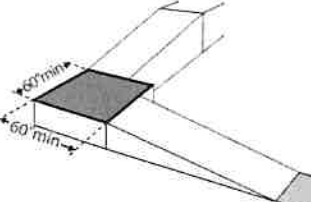
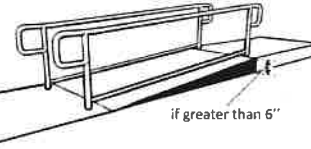
Ramps If any portion of the accessible route is steeper than 1:20, it should be treated as a ramp.				
<p>1.25 If there is a ramp is it at least 36 inches wide? [405.5]</p> <p>Note: If there are handrails, measure between the handrails.</p>	<p><input type="checkbox"/> Yes <input type="checkbox"/> No</p> <p>Measurement:</p> <p>NA</p>		<p>Photo #:</p>	<ul style="list-style-type: none"> • Alter ramp •
<p>1.26 Is the surface stable, firm and slip resistant? [405.4]</p>	<p><input checked="" type="checkbox"/> Yes <input type="checkbox"/> No</p> <p>NA</p>		<p>Photo #:</p>	<ul style="list-style-type: none"> • Resurface ramp • •
<p>1.27 For each section of the ramp, is the running slope no greater than 1:12, i.e. for every inch of height change there are at least 12 inches of ramp run? [405.2]</p> <p>Note: Rises no greater than 3 inches with a slope no steeper than 1:8 and rises no greater than 6 inches with a slope no steeper than 1:10 are permitted when such slopes are necessary due to space limitations.</p>	<p><input checked="" type="checkbox"/> Yes <input type="checkbox"/> No</p> <p>Measurement:</p> <p>1" : 12"</p>		<p>Photo #:</p>	<ul style="list-style-type: none"> • Relocate ramp • Lengthen ramp to decrease slope •

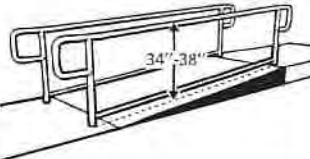
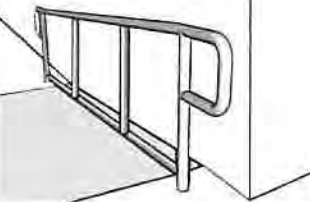
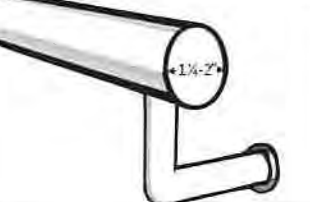
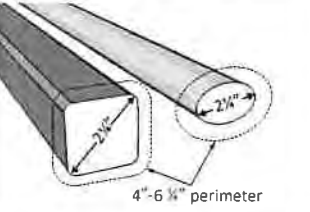

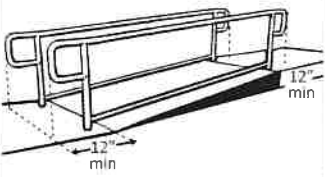
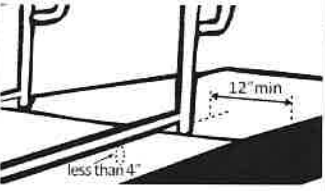
<p>1.28 Is there a level landing that is at least 60 inches long and at least as wide as the ramp:</p> <p>At the top of the ramp? <input checked="" type="checkbox"/> Yes <input type="checkbox"/> No</p> <p>Measurement: 72"</p> <p>At the bottom of the ramp? <input checked="" type="checkbox"/> Yes <input type="checkbox"/> No</p> <p>[405.7.2, 405.7.3]</p> <p>Measurement: 72"</p>	<p><input checked="" type="checkbox"/> Yes <input type="checkbox"/> No</p> <p>Measurement: 72"</p> <p><input checked="" type="checkbox"/> Yes <input type="checkbox"/> No</p> <p>Measurement: 72"</p>	 <p>landing widths must be at least equal to ramp width</p>	<p>Photo #:</p>	<ul style="list-style-type: none"> • Alter ramp • Relocate ramp •
<p>1.29 Is there a level landing where the ramp changes direction that is at least 60 x 60 inches? [405.7.4]</p>	<p><input checked="" type="checkbox"/> Yes <input type="checkbox"/> No</p> <p>Measurement: 60" x 60"</p>		<p>Photo #:</p>	<ul style="list-style-type: none"> • Alter ramp • Increase landing size •
<p>1.30 If the ramp has a rise higher than 6 inches, are there handrails on both sides? [405.8]</p> <p>Note: Curb ramps are not required to have handrails.</p>	<p><input type="checkbox"/> Yes <input type="checkbox"/> No</p> <p>Measurement: N/A</p>		<p>Photo #:</p>	<ul style="list-style-type: none"> • Add handrails • •

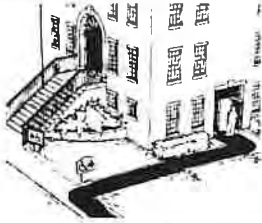
<p>1.31 Is the top of the handrail gripping surface no less than 34 inches and no greater than 38 inches above the ramp surface? [505.4]</p>	<p><input type="checkbox"/> Yes <input type="checkbox"/> No Measurement: <i>N/A</i></p>		<p>Photo #:</p>	<ul style="list-style-type: none"> • Reconfigure or replace handrails • Adjust handrail height
<p>1.32 Is the handrail gripping surface continuous and not obstructed along the top or sides? [505.3]</p> <p>If there are obstructions, is the bottom of the gripping surface obstructed no greater than 20%? [505.6]</p>	<p><input type="checkbox"/> Yes <input type="checkbox"/> No <i>N/A</i> <input type="checkbox"/> Yes <input type="checkbox"/> No Measurement: <i>N/A</i></p>		<p>Photo #:</p>	<ul style="list-style-type: none"> • Reconfigure or replace handrails
<p>1.33 If the handrail gripping surface is circular, is it no less than 1 1/4 inches and no greater than 2 inches in diameter? [505.7.1]</p>	<p><input type="checkbox"/> Yes <input type="checkbox"/> No Measurement: <i>N/A</i></p>		<p>Photo #:</p>	<ul style="list-style-type: none"> • Replace handrails
<p>1.34 If the handrail gripping surface is non-circular:</p> <p>Is the perimeter no less than 4 inches and no greater than 6 1/4 inches?</p>	<p><input type="checkbox"/> Yes <input type="checkbox"/> No Measurement: <i>N/A</i> <input type="checkbox"/> Yes <input type="checkbox"/> No Measurement: <i>N/A</i></p>		<p>Photo #:</p>	<ul style="list-style-type: none"> • Replace handrails

<p>Is the cross section no greater than 2¼ inches? [505.7.2]</p>	<p><input type="checkbox"/> Yes <input type="checkbox"/> No Measurement: <i>N/A</i></p>		<p>Photo #:</p>	
<p>1.35 Does the handrail:</p> <p>Extend at least 12 inches horizontally beyond the top and bottom of the ramp?</p> <p>Return to a wall, guard, or landing surface? [505.10.1]</p> <p>Note: If a 12 inch extension would be a hazard (in circulation path) it is not required.</p>	<p><input type="checkbox"/> Yes <input type="checkbox"/> No Measurement: <i>N/A</i></p> <p><input type="checkbox"/> Yes <input type="checkbox"/> No <i>N/A</i></p>		<p>Photo #:</p>	<ul style="list-style-type: none"> • Alter handrails • •
<p>1.36 To prevent wheelchair casters and crutch tips from falling off:</p> <p>Does the surface of the ramp extend at least 12 inches beyond the inside face of the handrail? Or Is there a curb or barrier that prevents the passage of a 4-inch diameter sphere? [405.9.1, 405.9.2]</p>	<p><input type="checkbox"/> Yes <input type="checkbox"/> No Measurement: <i>N/A</i></p> <p><input type="checkbox"/> Yes <input type="checkbox"/> No Measurement: <i>N/A</i></p>		<p>Photo #:</p>	<ul style="list-style-type: none"> • Add curb • Add barrier • Extend ramp width •

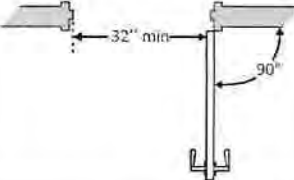
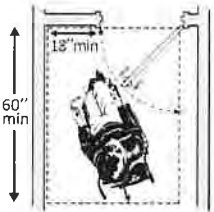
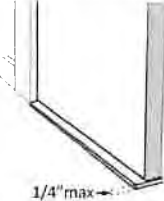
Entrance				
<p>1.37 Is the main entrance accessible?</p>	<p><input checked="" type="checkbox"/> Yes <input type="checkbox"/> No</p>		<p>Photo #:</p>	<ul style="list-style-type: none"> • Redesign to make it accessible • •
<p>1.38 If the main entrance is not accessible, is there an alternative accessible entrance? Can the alternative accessible entrance be used independently and during the same hours as the main entrance?</p>	<p><input type="checkbox"/> Yes <input type="checkbox"/> No N/A <input type="checkbox"/> Yes <input type="checkbox"/> No N/A</p>		<p>Photo #:</p>	<ul style="list-style-type: none"> • Designate an entrance and make it accessible • Ensure that accessible entrance can be used independently and during the same hours as the main entrance •
<p>1.39 Do all inaccessible entrances have signs indicating the location of the nearest accessible entrance? [216.6]</p>	<p><input type="checkbox"/> Yes <input checked="" type="checkbox"/> No</p>		<p>Photo #:</p>	<ul style="list-style-type: none"> • Install signs • Install signs on route before people get to inaccessible entrances so that people do not have to turn around and retrace route •
<p>1.40 If not all entrances are accessible, is there a sign at the accessible entrance with the International Symbol of Accessibility? [216.6]</p>	<p><input checked="" type="checkbox"/> Yes <input type="checkbox"/> No</p>		<p>Photo #:</p>	<ul style="list-style-type: none"> • Install sign • •

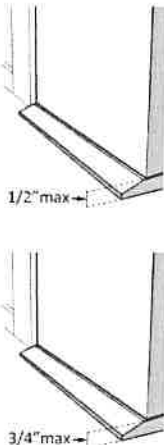
<p>1.41 Is the clear opening width of the accessible entrance door at least 32 inches, between the face of the door and the stop, when the door is open 90 degrees? [404.2.3]</p>	<p><input checked="" type="checkbox"/> Yes <input type="checkbox"/> No Measurement: 33"</p>		<p>Photo #:</p>	<ul style="list-style-type: none"> • Alter door • Install offset hinges •
<p>1.42 If there is a front approach to the pull side of the door, is there at least 18 inches of maneuvering clearance beyond the latch side plus at least 60 inches clear depth? Note: See 2010 Standards 404.2.4 for maneuvering clearance requirements on the push side of the door and side approaches to the pull side of the door On both sides of the door, is the ground or floor surface of the maneuvering clearance level (no steeper than 1:48)? [404.2.4]</p>	<p><input type="checkbox"/> Yes <input type="checkbox"/> No Measurement: NA</p> <p><input checked="" type="checkbox"/> Yes <input type="checkbox"/> No Measurement: LEVEL</p>		<p>Photo #:</p>	<ul style="list-style-type: none"> • Remove obstructions • Reconfigure walls • Add automatic door opener
<p>1.43 If the threshold is vertical is it no more than 1/4 inch high? Or No more than 1/2 inch high with the top 1/4 inch beveled no steeper than 1:2, if the threshold was installed on or</p>	<p><input type="checkbox"/> Yes <input type="checkbox"/> No Measurement: NA</p> <p><input type="checkbox"/> Yes <input type="checkbox"/> No Measurement: NA</p>		<p>Photo #:</p>	<ul style="list-style-type: none"> • Remove or replace threshold • •

<p>after the 1991 ADA Standards went into effect (1/26/93)?</p> <p>Or</p> <p>No more than 3/4 inch high with the top 1/2 inch beveled no steeper than 1:2, if the threshold was installed before the 1991 ADA Standards went into effect (1/26/93)? [404.2.5, 303.2]</p> <p>Note: The first 1/4 inch of the 1/2 or 3/4 inch threshold may be vertical; the rest must be beveled.</p>	<p><input checked="" type="checkbox"/> Yes <input type="checkbox"/> No</p> <p>Measurement: <i>1/2" TOP</i> <i>1/4" BOTTOM</i></p>		<p>Photo #:</p>	
<p>1.44 Is the door equipped with hardware that is operable with one hand and does not require tight grasping, pinching or twisting of the wrist?</p> <p>Door handle?</p> <p>Lock (if provided)? [404.2.7]</p>	<p><input checked="" type="checkbox"/> Yes <input type="checkbox"/> No <i>Door Pull</i></p> <p><input type="checkbox"/> Yes <input checked="" type="checkbox"/> No</p> <p><input checked="" type="checkbox"/> Yes <input type="checkbox"/> No</p>		<p>Photo #:</p>	<ul style="list-style-type: none"> • Replace inaccessible knob with lever, loop or push hardware • Add automatic door opener

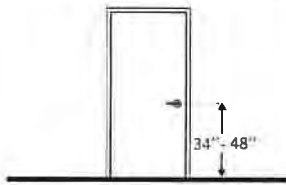
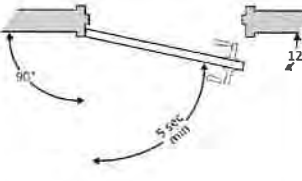
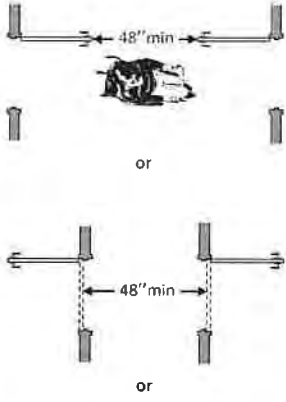
<p>1.45 Are the operable parts of the door hardware no less than 34 inches and no greater than 48 inches above the floor or ground surface? [404.2.7]</p>	<p><input checked="" type="checkbox"/> Yes <input type="checkbox"/> No Measurement: 36"</p>		<p>Photo #:</p>	<ul style="list-style-type: none"> • Change hardware height
<p>1.46 If the door has a closer, does it take at least 5 seconds to close from an open position of 90 degrees to a position of 12 degrees from the latch? [404.2.8]</p>	<p><input checked="" type="checkbox"/> Yes <input type="checkbox"/> No Measurement: 5 SEC.</p>		<p>Photo #:</p>	<ul style="list-style-type: none"> • Adjust closer
<p>1.47 If there are two doors in a series, e.g. vestibule, is the distance between the doors at least 48 inches plus the width of the doors when swinging into the space? [404.2.6]</p>	<p><input type="checkbox"/> Yes <input type="checkbox"/> No Measurement: N/A</p>		<p>Photo #:</p>	<ul style="list-style-type: none"> • Remove inner door • Change door swing

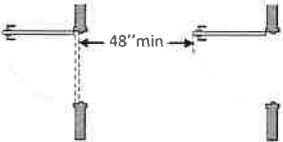
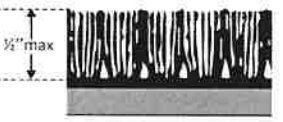
			Photo #:	
<p>1.48 If provided at the building entrance, are carpets or mats no higher than ½ inch thick? [302.2]</p>	<p><input type="checkbox"/> Yes <input type="checkbox"/> No Measurement: N/A</p>		Photo #:	<ul style="list-style-type: none"> • Replace or remove mats • •
<p>1.49 Are edges of carpets or mats securely attached to minimize tripping hazards? [302.2]</p>	<p><input type="checkbox"/> Yes <input type="checkbox"/> No N/A</p>		Photo #:	<ul style="list-style-type: none"> • Secure carpeting or mats at edges • •
	<p><input type="checkbox"/> Yes <input type="checkbox"/> No N/A</p>		Photo #:	<ul style="list-style-type: none"> • • •
	<p><input type="checkbox"/> Yes <input type="checkbox"/> No N/A</p>		Photo #:	<ul style="list-style-type: none"> • • •

ADA Checklist for Existing Facilities

Priority 2 – Access to Goods & Services

Based on the 2010 ADA Standards for Accessible Design

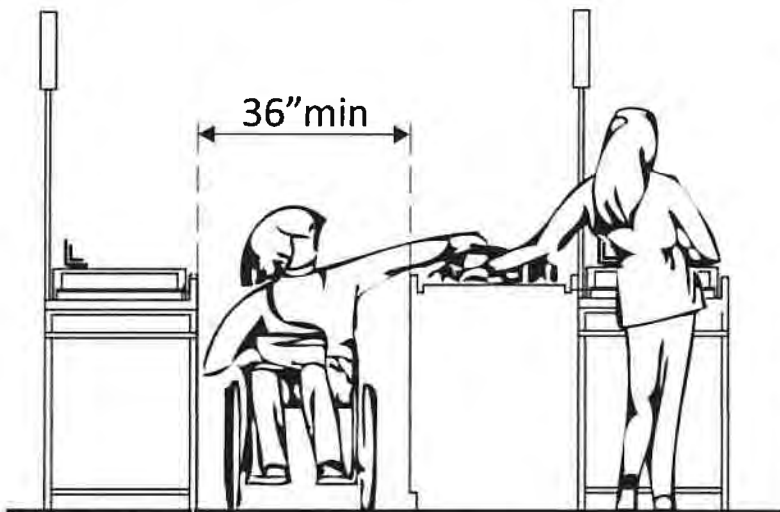

Project ADA TRANSITION PLAN

Building FIRE DEPARTMENT

Location WEAVERVILLE N.C.

Date 4-20-2020

Surveyors ALAN F. MACKAY

Contact Information KYLE DAVIS

The layout of the building should allow people with disabilities to obtain goods and services and to participate in activities without assistance.



Institute for Human Centered Design
www.HumanCenteredDesign.org
Copyright © 2016



ADA National Network
Questions on the ADA 800-949-4232 voice/tty
www.ADAchecklist.org

This checklist was produced by the New England ADA Center, a project of the Institute for Human Centered Design and a member of the ADA National Network. This checklist was developed under a grant from the Department of Education, NIDRR grant number H133A060092-09A. However the contents do not necessarily represent the policy of the Department of Education, and you should not assume endorsement by the Federal Government.

Questions or comments on the checklist contact the New England ADA Center at 617-695-0085 voice/tty or ADAinfo@NewEnglandADA.org

For the full set of checklists, including the checklists for recreation facilities visit www.ADAchecklist.org.

Copyright © 2016 ADA Checklist for Existing Materials. You can freely reproduce and distribute this content. Include proper attribution. But you must get permission before using this content as a fee-based product.

Priority 2 – Access to Goods & Services		Comments	Possible Solutions
<p>2.1 Does the accessible entrance provide direct access to the main floor, lobby and elevator? [See 2010 ADA Standards for Accessible Design – 206.4]</p>	<input checked="" type="checkbox"/> Yes <input type="checkbox"/> No	<p>Photo #:</p>	<ul style="list-style-type: none"> • Create accessible route • •
Interior Accessible Route			
<p>2.2 Are all public spaces on at least one accessible route? [206.2.4]</p>	<input checked="" type="checkbox"/> Yes <input type="checkbox"/> No	<p>Photo #:</p>	<ul style="list-style-type: none"> • Create accessible route • •
<p>2.3 Is the route stable, firm and slip-resistant? [40.2, 302.1]</p>	<input checked="" type="checkbox"/> Yes <input type="checkbox"/> No	<p>Photo #:</p>	<ul style="list-style-type: none"> • Repair uneven surfaces • •
<p>2.4 Is the route at least 36 inches wide? [403.5.1]</p> <p>Note: The accessible route can narrow to 32 inches min. for a max. of 24 inches. These narrower portions of the route must be at least 48 inches from each other.</p>	<p>Measurement:</p> <p>+ 36"^u</p>	 <p>A diagram showing a wheelchair on a path between two parallel lines. A vertical double-headed arrow indicates a width of 36 inches, labeled '36" min'. The wheelchair is positioned within this width.</p>	<ul style="list-style-type: none"> • Widen route • •

			<p>Photo #:</p>	
<p>2.5 If the route is greater than 200 feet in length and less than 60 inches wide, is there a passing space no less than 60 x 60 inches? [403.5.3]</p>	<p><input type="checkbox"/> Yes <input type="checkbox"/> No</p> <p>Measurement: NA</p>		<p>Photo #:</p>	<ul style="list-style-type: none"> • Widen route for passing space • •
<p>2.6 Is the running slope no steeper than 1:20, i.e. for every inch of height change there are at least 20 inches of route run? [403.3]</p> <p>Note: If the running slope is steeper than 1:20, treat as a ramp and add features such as edge protection and handrails.</p>	<p><input type="checkbox"/> Yes <input type="checkbox"/> No</p> <p>Measurement: NA</p>		<p>Photo #:</p>	<ul style="list-style-type: none"> • Regrade • •
<p>2.7 Is the cross slope no steeper than 1:48? [403.3]</p>	<p><input type="checkbox"/> Yes <input type="checkbox"/> No</p> <p>Measurement: NA</p>		<p>Photo #:</p>	<ul style="list-style-type: none"> • Regrade • •

2.8 Do all objects on circulation paths through public areas, e.g. fire extinguishers, drinking fountains, signs, etc., protrude no more than 4 inches into the path?

Yes No

Measurement:

NA

Or

If an object protrudes more than 4 inches, is the bottom leading edge at 27 inches or lower above the floor? [307.2]

Yes No

Measurement:

NA

Or

Is the bottom leading edge at 80 inches or higher above the floor? [307.4]

Yes No

Measurement:

NA



Or

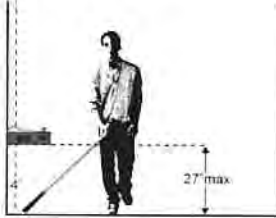

Or

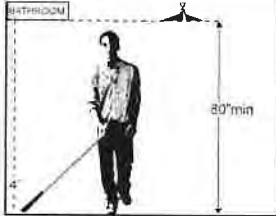

Photo #:

- Remove object
- Add tactile warning such as permanent planter or partial walls
-

2.9 Are there elevators or platform lifts to all public stories?

Yes No

Note: Vertical access is not required in new construction or alterations if a facility is less than three stories or has less than 3,000 square feet per story, unless the facility is a shopping center, shopping mall,

NA

- Install if necessary
- Offer goods and services on an accessible story
-

professional office of a health care provider, transportation terminal, state facility or local government facility

Photo #:

Ramps

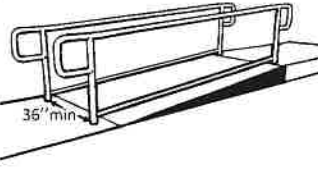
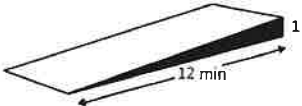
<p>2.10 If there is a ramp, is it at least 36 inches wide? [405.5]</p> <p>Note: If there are handrails, measure between the handrails.</p>	<p><input type="checkbox"/> Yes <input type="checkbox"/> No</p> <p>Measurement: NA</p>		<p>Photo #:</p> <ul style="list-style-type: none"> • Alter ramp • •
<p>2.11 Is the surface stable, firm and slip resistant? [405.4]</p>	<p><input type="checkbox"/> Yes <input type="checkbox"/> No</p> <p>NA</p>		<p>Photo #:</p> <ul style="list-style-type: none"> • Resurface ramp • •
<p>2.12 For each section of the ramp, is the running slope no greater than 1:12, i.e. for every inch of height change there are at least 12 inches of ramp run? [405.2]</p> <p>Note: Rises no greater than 3 inches with a slope no steeper than 1:8 and rises no greater</p>	<p><input type="checkbox"/> Yes <input type="checkbox"/> No</p> <p>Measurement: NA</p>		<ul style="list-style-type: none"> • Lengthen ramp to decrease slope • Relocate ramp •

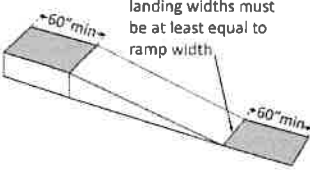
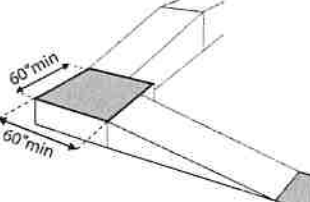
<p>than 6 inches with a slope no steeper than 1:10 are permitted when due to space limitations.</p>			<p>Photo #:</p>	
<p>2.13 Is there a level landing that is at least 60 inches long and at least as wide as the ramp:</p> <p>At the top of the ramp?</p> <p>At the bottom of the ramp? [405.7.2, 405.7.3]</p>	<p><input type="checkbox"/> Yes <input type="checkbox"/> No <i>NA</i> Measurement: <i>NA</i></p> <p><input type="checkbox"/> Yes <input type="checkbox"/> No Measurement: <i>NA</i></p>		<p>Photo #:</p>	<ul style="list-style-type: none"> • Alter ramp • Relocate ramp •
<p>2.14 Is there a level landing where the ramp changes direction that is at least 60 x 60 inches? [405.7.4]</p>	<p><input type="checkbox"/> Yes <input type="checkbox"/> No Measurement: <i>NA</i></p>		<p>Photo #:</p>	<ul style="list-style-type: none"> • Increase landing size • •

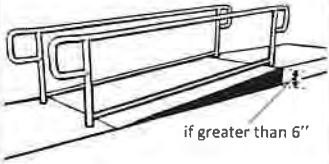
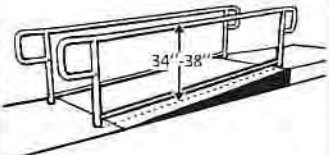
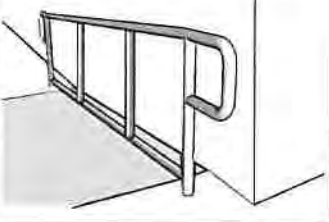
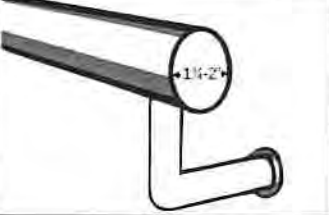
<p>2.15 If the ramp has a rise higher than 6 inches are there handrails on both sides? [405.8]</p>	<p><input type="checkbox"/> Yes <input type="checkbox"/> No Measurement: NA</p>		<p>Photo #:</p>	<ul style="list-style-type: none"> • Add handrails • •
<p>2.16 Is the top of the handrail gripping surface no less than 34 inches and no greater than 38 inches above the ramp surface? [505.4]</p>	<p><input type="checkbox"/> Yes <input type="checkbox"/> No Measurement: NA</p>		<p>Photo #:</p>	<ul style="list-style-type: none"> • Adjust handrail height • •
<p>2.17 Is the handrail gripping surface continuous and not obstructed along the top or sides? [505.3]</p> <p>If there are obstructions, is the bottom of the gripping surface obstructed no more than 20%? [505.6]</p>	<p><input type="checkbox"/> Yes <input type="checkbox"/> No NA <input type="checkbox"/> Yes <input type="checkbox"/> No Measurement: NA</p>		<p>Photo #:</p>	<ul style="list-style-type: none"> • Reconfigure or replace handrails • •
<p>2.18 If the handrail gripping surface is circular, is it no less than 1 1/4 inches and no greater than 2 inches in diameter? [505.7.1]</p>	<p><input type="checkbox"/> Yes <input type="checkbox"/> No Measurement: NA</p>		<p>Photo #:</p>	<ul style="list-style-type: none"> • Replace handrails • •

2.19 If the handrail gripping surface is non-circular:

Is the perimeter no less than 4 inches and no greater than 6 1/4 inches?

Yes No

Measurement:

NA

Is the cross section no greater than 2 1/4 inches in diameter? [505.7.2]

Yes No

Measurement:

NA

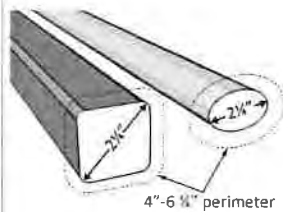

Photo #:

- Replace handrails
-
-

2.20 Does the handrail:

Extend at least 12 inches horizontally beyond the top and bottom of the ramp?

Yes No

Measurement:

NA

Return to a wall, guard, or landing surface? [505.10.1]

Yes No

Note: If a 12" extension would be hazardous (in circulation path), it is not required

NA

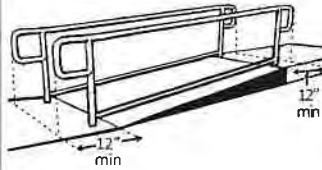

Photo #:

- Alter handrails
-
-

2.21 To prevent wheelchair casters and crutch tips from falling off:

Does the surface of the ramp extend at least 12 inches beyond the inside face of the handrail?

Yes No

Measurement:

NA

Or

Yes No

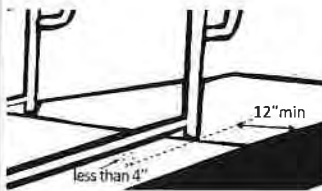
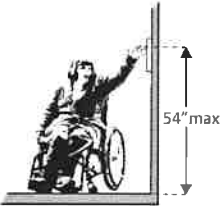
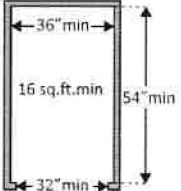
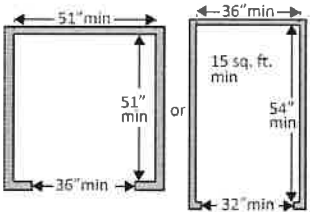

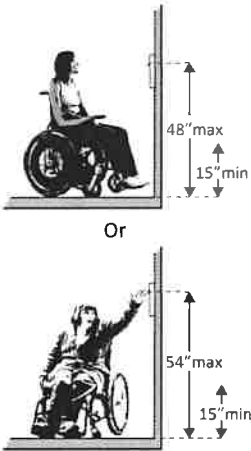

Photo #:

- Add curb
- Add barrier
- Extend ramp width
-
-

<p>Is there a curb or barrier that prevents the passage of a 4-inch diameter sphere? [405.9.1, 405.9.2]</p>	<p>Measurement: NA</p>		<p>Photo #:</p>	
-----------------------------------------------------------------------------------------------------------------	----------------------------	--	-----------------	--

<p>Elevators – Full Size & LULA (limited use, limited application) LULA elevators are often used in alterations.</p>				
<p>2.22 If there is a full size or LULA elevator, are the call buttons no higher than 54 inches above the floor? [407.2.1.1]</p>	<p><input type="checkbox"/> Yes <input type="checkbox"/> No Measurement: NA</p>		<p>Photo #:</p>	<ul style="list-style-type: none"> • Change call button height • •
<p>2.23 If there is a full size or LULA elevator, does the sliding door reopen automatically when obstructed by an object or person?*</p>	<p><input type="checkbox"/> Yes <input type="checkbox"/> No NA</p>		<p>Photo #:</p>	<p>* If constructed before 3/15/2012 and manually operated, the door is not required to reopen automatically</p> <ul style="list-style-type: none"> • Install opener •

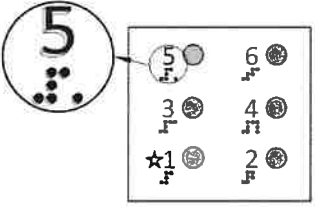

<p>2.24 If there is a LULA elevator with a swinging door:</p> <p>Is the door power- operated?</p> <p>Does the door remain open for at least 20 seconds when activated? [403.3.2]</p>	<p><i>NA</i></p> <p><input type="checkbox"/> Yes <input type="checkbox"/> No</p> <p><input type="checkbox"/> Yes <input type="checkbox"/> No</p> <p>Time: <i>NA</i></p>		<p>Photo #:</p>	<ul style="list-style-type: none"> • Add power operated door • Adjust opening time •
<p>2.25 If there is a full size elevator:</p> <p>Is the interior at least 54 inches deep by at least 36 inches wide with at least 16 sq. ft. of clear floor area?</p> <p>Is the door opening width at least 32 inches? [407.4.1 Exception]</p>	<p><input type="checkbox"/> Yes <input type="checkbox"/> No</p> <p>Measurement: <i>NA</i></p> <p><input type="checkbox"/> Yes <input type="checkbox"/> No</p> <p>Measurement: <i>NA</i></p>		<p>Photo #:</p>	<ul style="list-style-type: none"> • Replace elevator • •
<p>2.26 If there is a LULA elevator, is the interior:</p> <p>At least 51 inches deep by 51 inches wide with a door opening width of at least 36 inches?</p> <p>Or</p> <p>At least 54 inches deep by at least 36 inches wide with at least 15 sq. ft. of clear floor area and a door opening width of at least 32 inches? [408.4.1 Exceptions 1 and 2]</p>	<p><input type="checkbox"/> Yes <input type="checkbox"/> No</p> <p>Measurement: <i>NA</i></p> <p><input type="checkbox"/> Yes <input type="checkbox"/> No</p> <p>Measurement: <i>NA</i></p>		<p>Photo #:</p>	<ul style="list-style-type: none"> • Replace elevator • •

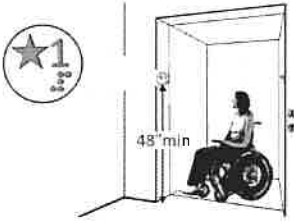
<p>2.27 If there is a full size or LULA elevator, are the in-car controls:</p> <p>No less than 15 inches and no greater 48 inches above the floor?</p> <p>Or</p> <p>Up to 54 inches above the floor for a parallel approach? [408.4.6, 407.4.6.1]</p>	<p><input type="checkbox"/> Yes <input type="checkbox"/> No</p> <p>Measurement: NA</p> <p><input type="checkbox"/> Yes <input type="checkbox"/> No</p> <p>Measurement: NA</p>		<p>Photo #:</p>	<ul style="list-style-type: none"> • Change control height •
<p>2.28 If there is a LULA elevator, are the in-car controls centered on a side wall? [408.4.6]</p>	<p><input type="checkbox"/> Yes <input type="checkbox"/> No</p> <p>Measurement: NA</p>		<p>Photo #:</p>	<ul style="list-style-type: none"> • Reconfigure controls • •
<p>2.29 If there is a full size or LULA elevator:</p> <p>Are the car control buttons designated with raised characters?</p> <p>Are the car control buttons designated with Braille?</p>	<p><input type="checkbox"/> Yes <input type="checkbox"/> No</p> <p>NA</p> <p><input type="checkbox"/> Yes <input type="checkbox"/> No</p> <p>NA</p>		<p>Photo #:</p>	<ul style="list-style-type: none"> • Add raised characters • Add Braille •

[407.4.7.1, 703.2]			Photo #:	
<p>2.30 If there is a full size or LULA elevator, are there audible signals which sound as the car passes or is about to stop at a floor? [407.4.8]</p>	<p><input type="checkbox"/> Yes <input type="checkbox"/> No</p> <p>NA</p>		Photo #:	<ul style="list-style-type: none"> • Install audible signals • •
<p>2.31 If there is a full size or LULA elevator:</p> <p>Is there a sign on both door jambs at every floor identifying the floor?</p> <p>Is there a tactile star on both jambs at the main entry level?</p> <p>Do text characters contrast with their backgrounds?</p> <p>Are text characters raised?</p> <p>Is there Braille?</p> <p>Is the sign mounted between 48 inches to the baseline of the lowest character and 60 inches to the baseline of the highest character above the floor?*</p> <p>[407.2.3, 408.2.3]</p>	<p><input type="checkbox"/> Yes <input type="checkbox"/> No</p> <p><input type="checkbox"/> Yes <input type="checkbox"/> No</p> <p><input type="checkbox"/> Yes <input type="checkbox"/> No</p> <p><input type="checkbox"/> Yes <input type="checkbox"/> No</p> <p><input type="checkbox"/> Yes <input type="checkbox"/> No</p> <p><input type="checkbox"/> Yes <input type="checkbox"/> No</p> <p>Measurement: NA</p>		Photo #:	<ul style="list-style-type: none"> • Install signs • Change sign height • • <p>* If constructed before 3/15/2012 and mounted no higher than 60 inches to the centerline of the sign, relocation is not required</p>

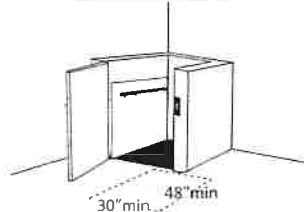
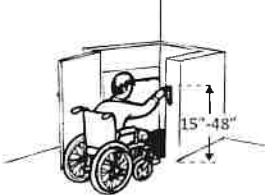
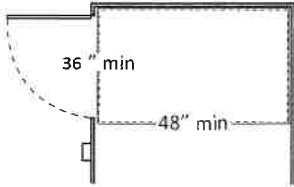
Platform Lifts

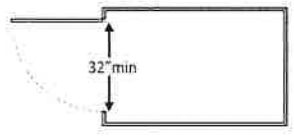
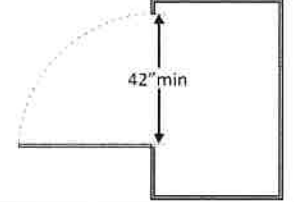
<p>2.32 If a lift is provided, can it be used without assistance from others? [410.1]</p>	<p><input type="checkbox"/> Yes <input type="checkbox"/> No</p> <p>NA</p>		<p>Photo #:</p>	<ul style="list-style-type: none"> • Reconfigure so independently operable • •
<p>2.33 Is there a clear floor space at least 30 inches wide by at least 48 inches long for a person using a wheelchair to approach and reach the controls to use the lift? [410.5]</p>	<p><input type="checkbox"/> Yes <input type="checkbox"/> No</p> <p>Measurement:</p> <p>NA</p>		<p>Photo #:</p>	<ul style="list-style-type: none"> • Remove obstructions • •
<p>2.34 Are the lift controls no less than 15 inches and no greater than 48 inches above the floor? [410.5]</p>	<p><input type="checkbox"/> Yes <input type="checkbox"/> No</p> <p>Measurement:</p> <p>NA</p>		<p>Photo #:</p>	<ul style="list-style-type: none"> • Change control height • •
<p>2.35 Is there a clear floor space at least 36 inches wide by at least 48 inches long inside the lift? [410.3]</p>	<p><input type="checkbox"/> Yes <input type="checkbox"/> No</p> <p>Measurement:</p> <p>NA</p>		<p>Photo #:</p>	<ul style="list-style-type: none"> • Replace lift • •

<p>2.36 If there is an end door, is the clear opening width at least 32 inches? [410.6]</p>	<p><input type="checkbox"/> Yes <input type="checkbox"/> No</p> <p>Measurement: NA</p>		<p>Photo #:</p>	<ul style="list-style-type: none"> • Alter door width • •
<p>2.37 If there is a side door, is the clear opening width at least 42 inches? [410.6]</p>	<p><input type="checkbox"/> Yes <input type="checkbox"/> No</p> <p>Measurement: NA</p>		<p>Photo #:</p>	<ul style="list-style-type: none"> • Alter door width • •
<p>Signs "Tactile characters" are read using touch, i.e. raised characters and Braille.</p>				
<p>2.38 If there are signs designating permanent rooms and spaces not likely to change over time, e.g. room numbers and letters, room names, and exit signs: [216.2]</p> <p>Do text characters contrast with their backgrounds? [703.5]</p> <p>Are text characters raised? [703.2]</p> <p>Is there Braille? [703.3]</p> <p>Is the sign mounted:</p>	<p><input type="checkbox"/> Yes <input type="checkbox"/> No</p> <p>NA</p> <p><input type="checkbox"/> Yes <input type="checkbox"/> No</p> <p>NA</p> <p><input type="checkbox"/> Yes <input type="checkbox"/> No</p> <p>NA</p>		<p>Photo #:</p>	<ul style="list-style-type: none"> • Install tactile sign • Relocate sign •

On the wall on the latch side of the door?
[703.4.2]

Yes No

Note: Signs are permitted on the push side of doors with closers and without hold-open devices.

N/A

With clear floor space beyond the arc of the door swing and 45-degree open position, at least 18 x 18 inches centered on the tactile characters?*

Yes No

Measurement:

N/A

So the baseline of the lowest character is at least 48 inches above the floor and the baseline of the highest character is no more than 60 inches above the floor? *

Yes No

Measurement:

N/A

Note: If the sign is at double doors with one active leaf, the sign should be on the inactive leaf; if both leaves are active, the sign should be on the wall to the right of the right leaf.

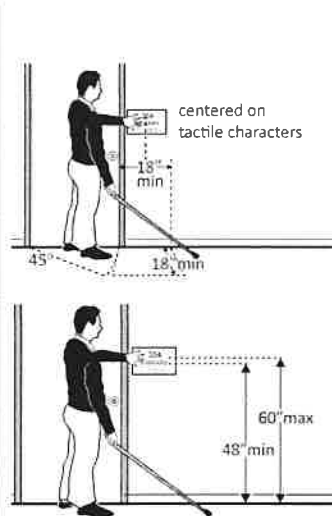



*If constructed before 3/15/2012 and a person may approach within 3 inches of the sign without encountering protruding objects or standing within the door swing, relocation not required

*If constructed before 3/15/2012 and mounted no higher than 60 inches to the centerline of the sign, relocation not required

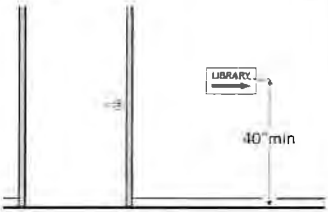
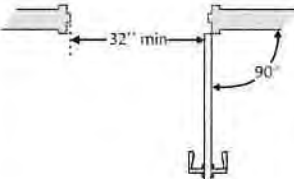
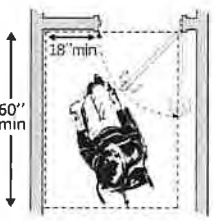
Photo #:

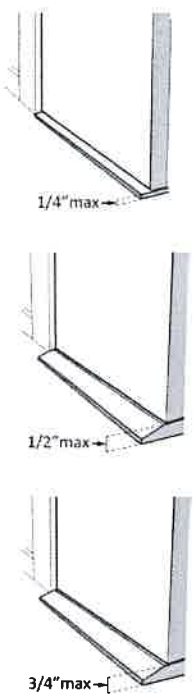
<p>2.39 If there are signs that provide direction to or information about interior spaces: Do text characters contrast with their backgrounds? [703.5.1] Is the sign mounted so that characters are at least 40 inches above the floor? [703.5.6] Note: Raised characters and Braille are not required.</p>	<p><input type="checkbox"/> Yes <input type="checkbox"/> No <input type="checkbox"/> Yes <input type="checkbox"/> No Measurement: NA</p>		<p>Photo #:</p>	<ul style="list-style-type: none"> • Install signs with contrasting characters • Change sign height •
Interior Doors – to classrooms, medical exam rooms, conference rooms, etc.				
<p>2.40 Is the door opening width at least 32 inches clear, between the face of the door and the stop, when the door is open 90 degrees? [404.2.3]</p>	<p><input type="checkbox"/> Yes <input type="checkbox"/> No Measurement: NA</p>		<p>Photo #:</p>	<ul style="list-style-type: none"> • Install offset hinges • Alter the doorway •
<p>2.41 If there is a front approach to the pull side of the door, is there at least 18 inches of maneuvering clearance beyond the latch side plus at least 60 inches clear depth? Note: See 2010 Standards 404.2.4 for maneuvering clearance requirements on the push side of the door and side approaches to the pull side of the door.</p>	<p><input type="checkbox"/> Yes <input type="checkbox"/> No Measurement: NA</p>		<p>Photo #:</p>	<ul style="list-style-type: none"> • Remove obstructions • Reconfigure walls • Add automatic door opener

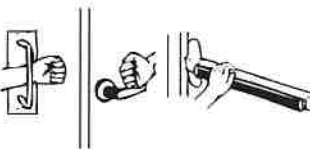
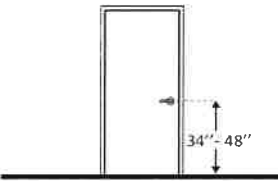
<p>On both sides of the door, is the floor surface of the maneuvering clearance level (no steeper than 1:48)? [404.2.4]</p>	<p><input type="checkbox"/> Yes <input type="checkbox"/> No Measurement: NA</p>		<p>Photo #:</p>	
<p>2.42 If the threshold is vertical is it no more than ¼ inch high? Or No more than ½ inch high with the top ¼ inch beveled no steeper than 1:2, if the threshold was installed on or after the 1991 ADA Standards went into effect (1/26/93)? Or No more than ¾ inch high with the top ½ inch beveled no steeper than 1:2, if the threshold was installed before the 1991 ADA Standards went into effect (1/26/93)? [404.2.5, 303.2] Note: The first ¼ inch of the ½ or ¾ inch threshold may be vertical; the rest must be beveled.</p>	<p><input type="checkbox"/> Yes <input type="checkbox"/> No Measurement: NA <input type="checkbox"/> Yes <input type="checkbox"/> No Measurement: NA <input type="checkbox"/> Yes <input type="checkbox"/> No Measurement: NA</p>		<p>Photo #:</p>	<ul style="list-style-type: none"> • Remove or replace threshold • •

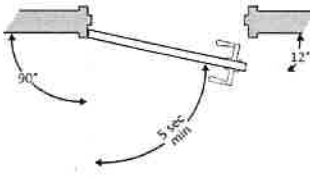
<p>2.43 Is the door equipped with hardware that is operable with one hand and does not require tight grasping, pinching or twisting of the wrist?</p> <p>Door handle?</p> <p>Lock (if provided)? [404.2.7]</p>	<p><input checked="" type="checkbox"/> Yes <input type="checkbox"/> No</p> <p><input type="checkbox"/> Yes <input type="checkbox"/> No</p> <p><input checked="" type="checkbox"/> Yes <input type="checkbox"/> No</p>		<p>Photo #:</p>	<ul style="list-style-type: none"> • Replace inaccessible knob with lever, loop or push hardware • Add automatic door opener •
<p>2.44 Are the operable parts of the hardware no less than 34 inches and no greater than 48 inches above the floor? [404.2.7]</p>	<p><input checked="" type="checkbox"/> Yes <input type="checkbox"/> No</p> <p>Measurement: 36"</p>		<p>Photo #:</p>	<ul style="list-style-type: none"> • Change hardware height • •
<p>2.45 Can the door be opened easily (5 pounds maximum force)? [404.2.9]</p> <p>Note: You can use a pressure gauge or fish scale to measure force. If you do not have one you will need to judge whether the door is easy to open.</p>	<p><input type="checkbox"/> Yes <input checked="" type="checkbox"/> No</p> <p>Measurement: 8 LBS</p>		<p>Photo #:</p>	<ul style="list-style-type: none"> • Adjust or replace closers • Install lighter doors • Install power-assisted or automatic door openers
<p>2.46 If the door has a closer, does it take at least 5 seconds to close from an open position of 90 degrees to a position of 12 degrees from the latch? [404.2.8.1]</p>	<p><input checked="" type="checkbox"/> Yes <input type="checkbox"/> No</p> <p>Measurement: 5 SECS.</p>		<p>Photo #:</p>	<ul style="list-style-type: none"> • Adjust closer • •

Rooms and Spaces – stores, supermarkets, libraries, etc.

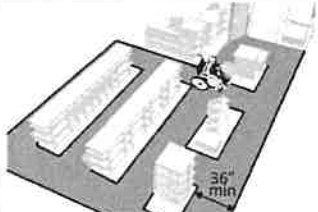
<p>2.47 Are aisles and pathways to goods and services, and to one of each type of sales and service counters, at least 36 inches wide? [403.5.1]</p>	<p><input type="checkbox"/> Yes <input type="checkbox"/> No</p> <p>Measurement:</p>		<p>Photo #:</p>	<ul style="list-style-type: none"> • Rearrange goods, equipment and furniture • •
-------------------------------------------------------------------------------------------------------------------------------------------------------------	-------------------------------------------------------------------------------------	-----------------------------------------------------------------------------------	-----------------	--------------------------------------------------------------------------------------------------------------------

<p>2.48 Are floor surfaces stable, firm and slip resistant? [302.1]</p>	<p><input type="checkbox"/> Yes <input type="checkbox"/> No</p>		<p>Photo #:</p>	<ul style="list-style-type: none"> • Change floor surface • •
--------------------------------------------------------------------------------	-----------------------------------------------------------------	--	-----------------	------------------------------------------------------------------------------------------------

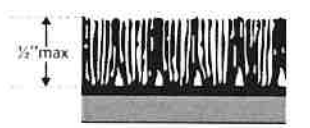
<p>2.49 If there is carpet:</p> <p>Is it no higher than 1/2 inch?</p> <p>Is it securely attached along the edges?</p> <p>[302.2]</p>	<p><input type="checkbox"/> Yes <input type="checkbox"/> No</p> <p>Measurement:</p> <p><input type="checkbox"/> Yes <input type="checkbox"/> No</p>		<p>Photo #:</p>	<ul style="list-style-type: none"> • Replace carpet • •
---------------------------------------------------------------------------------------------------------------------------------------------	-----------------------------------------------------------------------------------------------------------------------------------------------------	-------------------------------------------------------------------------------------	-----------------	------------------------------------------------------------------------------------------

Controls – light switches, security and intercom systems, emergency/alarm boxes, etc.

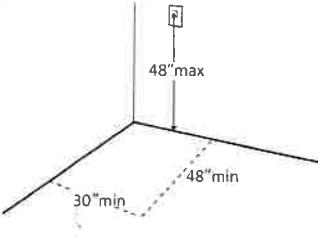
<p>2.50 Is there a clear floor space at least 30 inches wide by at least 48 inches long for a forward or parallel approach? [305.3]</p> <p>Are the operable parts no higher than 48 inches above the floor?*</p> <p>[309.3, 308]</p>	<p><input checked="" type="checkbox"/> Yes <input type="checkbox"/> No</p> <p>Measurement:</p> <p>48" 30"</p> <p><input checked="" type="checkbox"/> Yes <input type="checkbox"/> No</p> <p>Measurement:</p> <p>48"</p>		<p>Photo #:</p>	<ul style="list-style-type: none"> • Change height of control • • <p>*If constructed before 3/15/2012 and a parallel approach is provided, controls can be 54 inches above the floor</p>
---------------------------------------------------------------------------------------------------------------------------------------------------------------------------------------------------------------------------------------------	-----------------------------------------------------------------------------------------------------------------------------------------------------------------------------------------------------------------------------	-------------------------------------------------------------------------------------	-----------------	---------------------------------------------------------------------------------------------------------------------------------------------------------------------------------------------------------------------------

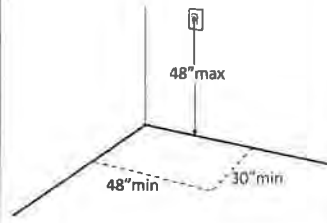

Photo #:

2.51 Can the control be operated with one hand and without tight grasping, pinching, or twisting of the wrist? [309.4]

Yes No



Photo #:

- Replace control
-
-

Seating: Assembly Areas – theaters, auditoriums, stadiums, theater style classrooms, etc.

2.52 Are an adequate number of wheelchair spaces provided? [221.2.1]

Yes No

Total #:

Wheelchair #:
NA

# of Seats	Wheelchair Spaces
4 - 25	1
26 - 50	2
51 - 150	4
151 - 300	5
300+ see 2010 Standards 221.2.1.	

Photo #:

- Reconfigure to add wheelchair spaces
-
-



2.53 Are wheelchair spaces dispersed to allow location choices and viewing angles equivalent to other seating, including specialty seating areas that provide distinct services and amenities? [221.2.3]

Yes No

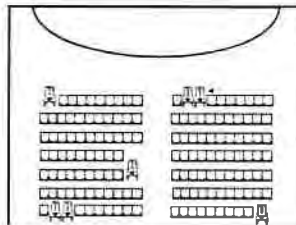

NA

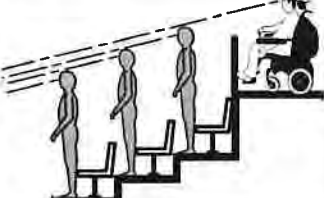

- Reconfigure to disperse wheelchair spaces
-
-

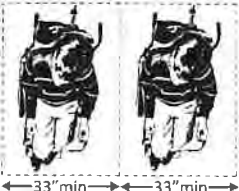
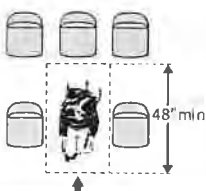
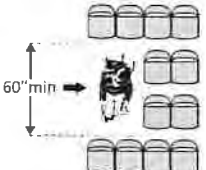
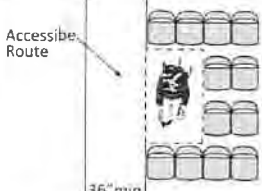
			Photo #:	
<p>2.54 Where people are expected to remain seated, do people in wheelchair spaces have a clear line of sight over and between the heads of others in front of them? [802.2.1.1, 802.1.1.2]</p>	<p><input type="checkbox"/> Yes <input type="checkbox"/> No</p> <p>NA</p>		Photo #:	<ul style="list-style-type: none"> • Alter for line of sight • •
<p>2.55 Where people are expected to stand, do people in wheelchair spaces have a clear line of sight over and between the heads of others in front of them? [802.2.2.1, 802.1.2.2]</p>	<p><input type="checkbox"/> Yes <input type="checkbox"/> No</p> <p>NA</p>		Photo #:	<ul style="list-style-type: none"> • Alter for line of sight • •
<p>2.56 If there is a single wheelchair space, is it at least 36 inches wide? [802.1.2]</p>	<p><input type="checkbox"/> Yes <input type="checkbox"/> No</p> <p>Measurement:</p> <p>NA</p>		Photo #:	<ul style="list-style-type: none"> • Alter space • •

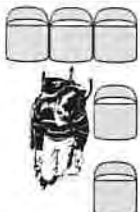
<p>2.57 If there are two adjacent wheelchair spaces, are they each at least 33 inches wide? [802.1.2]</p>	<p><input type="checkbox"/> Yes <input type="checkbox"/> No Measurement: NA</p>		<p>Photo #:</p>	<ul style="list-style-type: none"> • Alter spaces • •
<p>2.58 If the wheelchair space can be entered from the front or rear, is it at least 48 inches deep? [802.1.3]</p>	<p><input type="checkbox"/> Yes <input type="checkbox"/> No Measurement: NA</p>		<p>Photo #:</p>	<ul style="list-style-type: none"> • Alter space • •
<p>2.59 If the wheelchair space can only be entered from the side, is it at least 60 inches deep? [802.1.3]</p>	<p><input type="checkbox"/> Yes <input type="checkbox"/> No Measurement: NA</p>		<p>Photo #:</p>	<ul style="list-style-type: none"> • Alter space • •
<p>2.60 Do wheelchair spaces adjoin, but not overlap, accessible routes? [802.1.4]</p>	<p><input type="checkbox"/> Yes <input type="checkbox"/> No Measurement: NA</p>		<p>Photo #:</p>	<ul style="list-style-type: none"> • Alter spaces • •

<p>2.61 Is there at least one companion seat for each wheelchair space? [221.3]</p>	<p><input type="checkbox"/> Yes <input type="checkbox"/> No <i>NA</i></p>		<p>Photo #:</p>	<ul style="list-style-type: none"> • Add companion seats •
<p>2.62 Is the companion seat located so the companion is shoulder-to-shoulder with the person in a wheelchair? [802.3.1]</p>	<p><input type="checkbox"/> Yes <input type="checkbox"/> No <i>NA</i></p>		<p>Photo #:</p>	<ul style="list-style-type: none"> • Alter seating •
<p>2.63 Is the companion seat equivalent in size, quality, comfort and amenities to seating in the immediate area? [802.3.2]</p>	<p><input type="checkbox"/> Yes <input type="checkbox"/> No <i>NA</i></p>		<p>Photo #:</p>	<ul style="list-style-type: none"> • Add equivalent seating •
<p>Seating: At dining surfaces (restaurants, cafeterias, bars, etc.) and non-employee work surfaces (libraries, conference rooms, etc.)</p>				
<p>2.64 Are at least 5%, but no fewer than one, of seating and standing spaces accessible for people who use wheelchairs? [226.1]</p>	<p><input type="checkbox"/> Yes <input type="checkbox"/> No Total #: <i>NA</i> Wheelchair #:</p>		<p>Photo #:</p>	<ul style="list-style-type: none"> • Alter to provide accessible spaces •
<p>2.65 Is there a route at least 36 inches wide to accessible seating? [403.5.1]</p>	<p><input type="checkbox"/> Yes <input type="checkbox"/> No Measurement: <i>NA</i></p>		<p>Photo #:</p>	<ul style="list-style-type: none"> • Widen route •

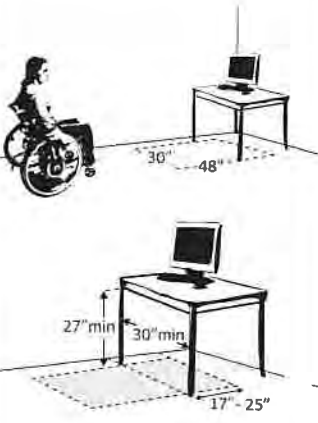
<p>2.66 At the accessible space(s), is the top of the accessible surface no less than 28 inches and no greater than 34 inches above the floor? [902.3]</p> <p>Note: If for children, the top should be no less than 26 inches and no greater than 30 inches above the floor.</p>	<p><input type="checkbox"/> Yes <input type="checkbox"/> No</p> <p>Measurement:</p> <p>NA</p>		<p>Photo #:</p>	<ul style="list-style-type: none"> • Alter surface height • •
<p>2.67 Is there a clear floor space at least 30 inches wide by at least 48 inches long for a forward approach? [305.3]</p> <p>Does it extend no less than 17 inches and no greater than 25 inches under the surface?</p> <p>Is there knee space at least 27 inches high and at least 30 inches wide? [306.2, 306.3]</p> <p>Note: If for children, the knee space may be 24 inches high.</p>	<p><input type="checkbox"/> Yes <input type="checkbox"/> No</p> <p>Measurement:</p> <p>NA</p> <p><input type="checkbox"/> Yes <input type="checkbox"/> No</p> <p>Measurement:</p> <p>NA</p> <p><input type="checkbox"/> Yes <input type="checkbox"/> No</p> <p>Measurement:</p> <p>NA</p>		<p>Photo #:</p>	<ul style="list-style-type: none"> • Alter table or work surface • Add accessible table or work surface •

Seating: General – reception areas, waiting rooms, etc.

2.68 Is there at least one space at least 36 inches wide by at least 48 inches long for a person in a wheelchair?
[802.1.2, 802.1.3]

Yes No

Measurement:

NA

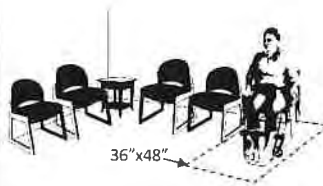

Photo #:

- Move furniture and equipment to provide space
-
-

Benches – In locker rooms, dressing rooms, fitting rooms This section does not apply to any other benches.

2.69 In locker rooms, dressing rooms and fitting rooms, is there at least one room with a bench?
[222.1, 803.4]

Yes No

NA

Photo #:

- Add bench
-
-

2.70 Is there a clear floor space at least 30 inches wide by at least 48 inches long at the end of the bench and parallel to the short axis of the bench?

Yes No

Measurement:

NA

Is the bench seat at least 42 inches long and no less than 20 inches and no greater than 24 inches deep?

Yes No

Measurement:

NA

Does the bench have back support or is it affixed to a wall?

Yes No

NA

Is the top of the bench seat no less than 17 inches and no greater than 19 inches above the floor?
[903]

Yes No

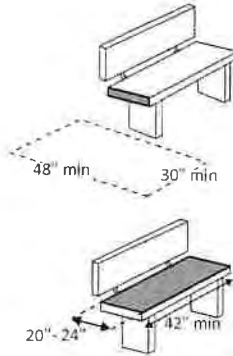

Measurement:

NA

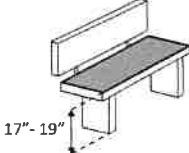
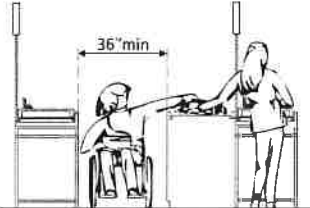
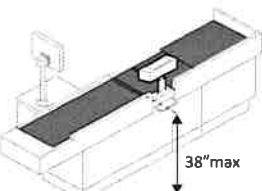
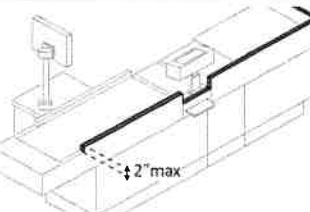

- Move bench
- Replace bench
- Affix bench to wall
-
-

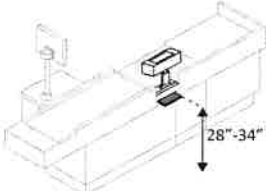
			<p>Photo #:</p>	
Check-Out Aisles – supermarkets, large retail stores, etc.				
<p>2.71 Is the aisle at least 36 inches wide? [904.3.1]</p>	<p><input type="checkbox"/> Yes <input type="checkbox"/> No</p> <p>Measurement: N/A</p>		<p>Photo #:</p>	<ul style="list-style-type: none"> • Widen aisle • •
<p>2.72 Is the counter surface of at least one aisle no higher than 38 inches above the floor? [904.3.2]</p>	<p><input type="checkbox"/> Yes <input type="checkbox"/> No</p> <p>Measurement: N/A</p>		<p>Photo #:</p>	<ul style="list-style-type: none"> • Lower counter • •
<p>2.73 Is the top of the counter edge protection no higher than 2 inches above the counter surface? [904.3.2]</p>	<p><input type="checkbox"/> Yes <input type="checkbox"/> No</p> <p>Measurement: N/A</p>		<p>Photo #:</p>	<ul style="list-style-type: none"> • Lower edge protection • •

<p>2.74 If there is a check writing surface, is the top no less than 28 inches and no greater than 34 inches above the floor? [904.3.3]</p>	<p><input type="checkbox"/> Yes <input type="checkbox"/> No Measurement: NA</p>		<p>Photo #:</p>	<ul style="list-style-type: none"> • Alter check writing surface • •
<p>2.75 If there is more than one check-out aisle is there a sign with the International Symbol of Accessibility at the accessible aisle? [216.11]</p>	<p><input type="checkbox"/> Yes <input type="checkbox"/> No NA</p>		<p>Photo #:</p>	<ul style="list-style-type: none"> • Add sign • •

Sales & Service Counters – banks, stores, dry cleaners, auto repair shops, fitness clubs, etc.

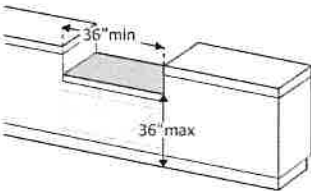
<p>2.76 Is there a portion of at least one of each type of counter that is: No higher than 36 inches above the floor? At least 36 inches long? [904.4.1]</p>	<p>NA <input type="checkbox"/> Yes <input type="checkbox"/> No Measurement: <input type="checkbox"/> Yes <input type="checkbox"/> No Measurement: NA</p>		<p>Photo #:</p>	<ul style="list-style-type: none"> • Lower section of counter • Lengthen section of counter •
-------------------------------------------------------------------------------------------------------------------------------------------------------------------------------------------------------------------------	----------------------------------------------------------------------------------------------------------------------------------------------------------------------------------------------------------------------------------------	-------------------------------------------------------------------------------------	-----------------	--------------------------------------------------------------------------------------------------------------------------------

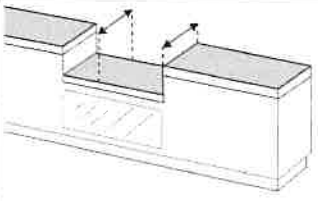
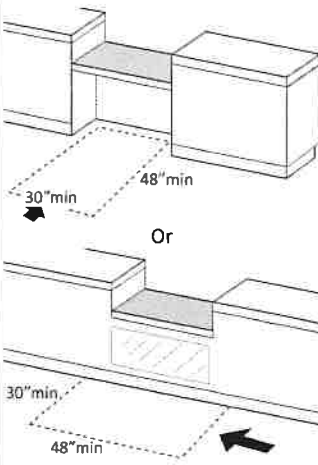
<p>2.77 Does the accessible portion of the counter extend the same depth as the counter top? [904.4]</p>	<p><input type="checkbox"/> Yes <input type="checkbox"/> No</p> <p>Measurement: <i>N/A</i></p>		<p>Photo #:</p> <ul style="list-style-type: none"> • Alter accessible portion • •
<p>2.78 Is there a clear floor space at least 30 inches wide by at least 48 inches long for a forward or parallel approach? [904.4]</p>	<p><input type="checkbox"/> Yes <input type="checkbox"/> No</p> <p><input type="checkbox"/> Parallel Measurement: <i>N/A</i></p> <p><input type="checkbox"/> Forward Measurement: <i>N/A</i></p>		<p>Photo #:</p> <ul style="list-style-type: none"> • Reconfigure to provide a parallel or forward approach • •

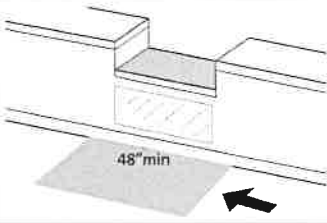
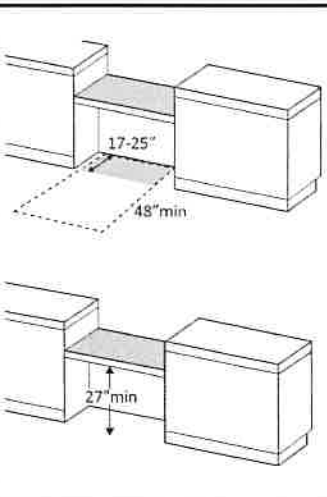
<p>2.79 For a parallel approach, is the clear floor space positioned with the 48 inches adjacent to the accessible length of counter? [904.4.1]</p>	<p><input type="checkbox"/> Yes <input type="checkbox"/> No Measurement: NA</p>		<p>Photo #:</p>	<ul style="list-style-type: none"> • If a parallel approach is not possible, a forward approach is required • •
<p>2.80 For a forward approach: Do no less than 17 and no greater than 25 inches of the clear floor space extend under the accessible length of the counter? [306.2.2, 306.2.3]</p> <p>Is there at least 27 inches clearance from the floor to the bottom of the counter? [306.3.1]</p>	<p><input type="checkbox"/> Yes <input type="checkbox"/> No Measurement: NA</p> <p><input type="checkbox"/> Yes <input type="checkbox"/> No Measurement: NA</p>		<p>Photo #:</p>	<ul style="list-style-type: none"> • Reconfigure to provide knee clearance • •

Food Service Lines – in cafeterias, salad bars, eat-in fast food establishments, etc.

2.81 Does at least one of each type of self-service shelf or dispensing device for tableware, dishware, condiments, food and beverages have a forward or parallel approach? [904.5.1]

Yes No

Forward

Parallel

NA

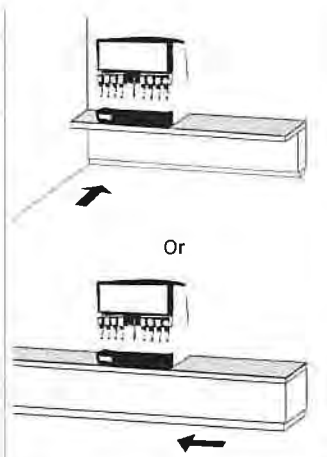

Photo #:

- Reconfigure to provide approach
-
-

2.82 If there is an unobstructed parallel approach, is the shelf or dispensing device no higher than 48 inches above the floor? [308.3.1]

Yes No

Measurement:

NA

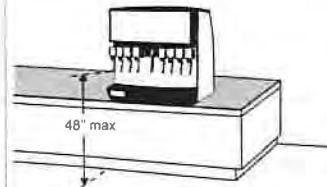

Photo #:

- Lower shelf and/or dispensing device
-
-

2.83 If there is a shallow obstruction no deeper than 10 inches with a parallel approach, is the shelf or dispensing device no higher than 48 inches above the floor? [308.3.1]

Yes No

Measurement:

NA

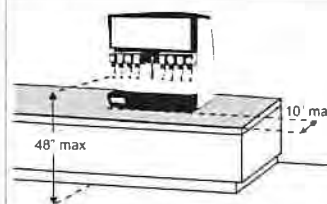
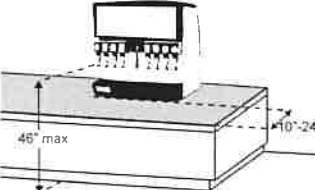
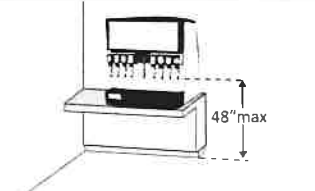
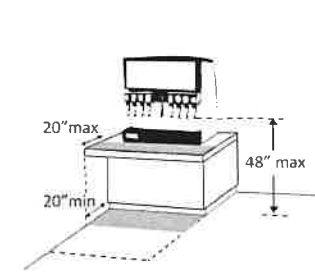
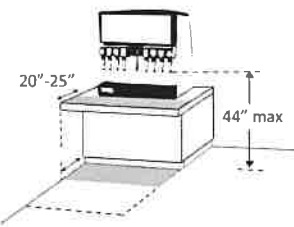
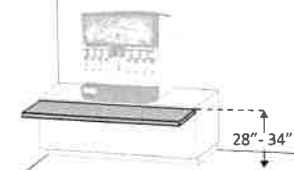

Photo #:

- Lower shelf and/or dispensing device
-
-

<p>2.84 If there is an obstruction no less than 10 inches and no greater than 24 inches deep with a parallel approach, is the shelf or dispensing device no higher than 46 inches above the floor? [308.3.2]</p>	<p><input type="checkbox"/> Yes <input type="checkbox"/> No Measurement: N/A</p>		<p>Photo #:</p>	<ul style="list-style-type: none"> • Lower shelf and/or dispensing device • •
<p>2.85 If there is an unobstructed forward approach, is the shelf or dispensing device no higher than 48 inches above the floor? [308.2.1]</p>	<p><input type="checkbox"/> Yes <input type="checkbox"/> No Measurement: N/A</p>		<p>Photo #:</p>	<ul style="list-style-type: none"> • Lower shelf and/or dispensing device • •
<p>2.86 If there is an obstruction no deeper than 20 inches with a forward approach: Does clear floor space extend under the obstruction that is at least the same depth as the obstruction? Is the shelf or dispensing device no higher than 48 inches above the floor? [904.5.1]</p>	<p><input type="checkbox"/> Yes <input type="checkbox"/> No Measurement: N/A <input type="checkbox"/> Yes <input type="checkbox"/> No Measurement: N/A</p>		<p>Photo #:</p>	<ul style="list-style-type: none"> • Reconfigure to provide knee space • Lower shelf and/or dispensing device •

<p>2.87 If the obstruction is no less than 20 inches and no greater than 25 inches deep with a forward approach:</p> <p>Does clear floor space extend under the obstruction that is at least the same depth as the obstruction?</p> <p>Is the shelf or dispensing device no higher than 44 inches above the floor? [904.5.1]</p>	<p><input type="checkbox"/> Yes <input type="checkbox"/> No Measurement: <i>N/A</i></p> <p><input type="checkbox"/> Yes <input type="checkbox"/> No Measurement: <i>N/A</i></p>		<p>Photo #:</p>	<ul style="list-style-type: none"> • Reconfigure to provide knee space • Lower shelf and/or dispensing device
<p>2.88 If there is a tray slide, is the top no less than 28 inches and no greater than 34 inches above the floor? [904.5.2]</p>	<p><input type="checkbox"/> Yes <input type="checkbox"/> No Measurement: <i>N/A</i></p>		<p>Photo #:</p>	<ul style="list-style-type: none"> • Reconfigure
	<p><input type="checkbox"/> Yes <input type="checkbox"/> No <i>N/A</i></p>		<p>Photo #:</p>	<ul style="list-style-type: none"> • • •
	<p><input type="checkbox"/> Yes <input type="checkbox"/> No <i>N/A</i></p>		<p>Photo #:</p>	<ul style="list-style-type: none"> • • •

The ADA Checklist for Existing Facilities

Priority 3 - Toilet Rooms

Based on the 2010 ADA Standards for Accessible Design

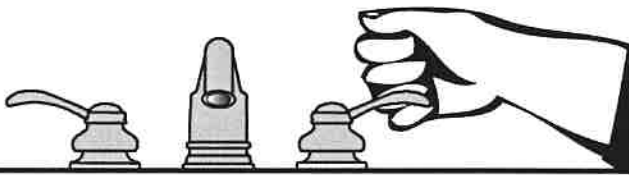

Project ADA TRANSITION PLAN

Building FIRE DEPARTMENT

Location WEAVERVILLE N.C.

Date 4-20-2020

Surveyors AMM F. WACKEY

Contact Information KYLE DAVIS

When toilet rooms are open to the public they should be accessible to people with disabilities.



Institute for Human Centered Design
www.HumanCenteredDesign.org
Copyright © 2016



ADA National Network
Questions on the ADA 800-949-4232 voice/tty
www.ADAchecklist.org

This checklist was produced by the New England ADA Center, a project of the Institute for Human Centered Design and a member of the ADA National Network. This checklist was developed under a grant from the Department of Education, NIDRR grant number H133A060092-09A. However the contents do not necessarily represent the policy of the Department of Education, and you should not assume endorsement by the Federal Government.

Questions or comments on the checklist contact the New England ADA Center at 617-695-0085 voice/tty or ADAinfo@NewEnglandADA.org

For the full set of checklists, including the checklists for recreation facilities visit www.ADAchecklist.org.

Copyright © 2016 ADA Checklist for Existing Materials. You can freely reproduce and distribute this content. Include proper attribution. But you must get permission before using this content as a fee-based product.



Priority 3 – Toilet Rooms		Comments	Possible Solutions
<p>3.1 If toilet rooms are available to the public, is at least one toilet room accessible? (Either one for each sex, or one unisex.)</p> <p>Note: If toilet rooms are chiefly for children, e.g., in elementary schools and day care centers, use the children’s specifications in Toilets - 604.1, 604.8, 604.9, 609.4 and Lavatories and Sinks – 606.2.</p>	<input checked="" type="checkbox"/> Yes <input type="checkbox"/> No		<ul style="list-style-type: none"> • Reconfigure toilet rooms • Combine toilet rooms to create one unisex accessible toilet room •
<p>3.2 Are there signs at inaccessible toilet rooms that give directions to accessible toilet rooms? [See 2010 ADA Standards for Accessible Design – 216.8]</p>	<input checked="" type="checkbox"/> Yes <input type="checkbox"/> No		<ul style="list-style-type: none"> • Install signs • •
<p>3.3 If not all toilet rooms are accessible, is there a sign at the accessible toilet room with the International Symbol of Accessibility? [216.8]</p>	<input checked="" type="checkbox"/> Yes <input type="checkbox"/> No		<ul style="list-style-type: none"> • Install sign • •
Accessible Route			
<p>3.4 Is there an accessible route to the accessible toilet room? [206.2.4]</p>	<input checked="" type="checkbox"/> Yes <input type="checkbox"/> No		<ul style="list-style-type: none"> • Alter route • •

Photo #:

Signs at Toilet Rooms

3.5 Do text characters contrast with their backgrounds? [703.5] Yes No

Are text characters raised? [703.2] Yes No

Is there Braille? [703.3] Yes No

Is the sign mounted: On the wall on the latch side of the door? [703.4.2] Yes No

Note: Signs are permitted on the push side of doors with closers and without hold-open devices.

With clear floor space beyond the arc of the door swing between the closed position and 45-degree open position, at least 18 x 18 inches centered on the tactile characters? * [703.4.2] Yes No
Measurement: +18"

So the baseline of the lowest character is at least 48 inches above the floor and the Yes No
Measurement: 60"

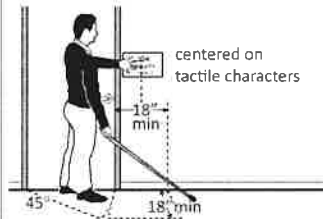
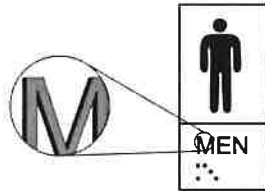

- Install tactile sign
- Relocate sign
-

*If constructed before 3/15/2012 and a person may approach within 3 inches of the sign without encountering protruding objects or standing within the door swing, relocation not required

ADA Checklist for Existing Facilities

Priority 3 – Toilet Rooms

baseline of the highest character is no more than 60 inches above the floor? * [703.4.1]

Note: If the sign is at double doors with one active leaf, the sign should be on the inactive leaf; if both leaves are active, the sign should be on the wall to the right of the right leaf.



Photo #:

*If constructed before 3/15/2012 and mounted no higher than 60 inches to the centerline of the sign, relocation is not required

Entrance

3.6 Is the door opening width at least 32 inches clear, between the face of the door and the stop, when the door is open 90 degrees? [404.2.3]

Yes No

Measurement:
33" ^{vt}

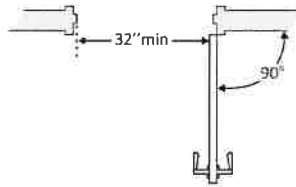

Photo #:

- Install offset hinges
- Alter the doorway
-

3.7 If there is a front approach to the pull side of the door is there at least 18 inches of maneuvering clearance beyond the latch side plus 60 inches clear depth?

Yes No

Measurement:

18"

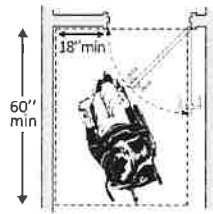

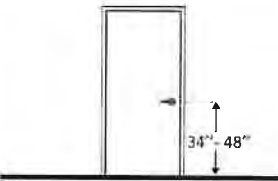

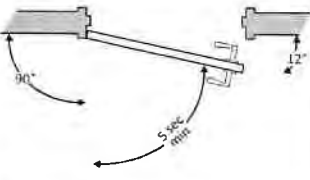

Photo #:

- Remove obstructions
- Reconfigure walls
- Add automatic door opener

<p>floor surface of the maneuvering clearance level (no steeper than 1:48)? [404.2.4]</p>	<p><input checked="" type="checkbox"/> Yes <input type="checkbox"/> No Measurement: LEVEL</p>		<p>Photo #:</p>	
<p>3.8 If the threshold is vertical is it no more than ¼ inch high? Or No more than ½ inch high with the top ¼ inch beveled no steeper than 1:2, if the threshold was installed on or after the 1991 ADA Standards went into effect (1/26/93)? Or No more than ¾ inch high with the top ½ inch beveled no steeper than 1:2, if the threshold was installed before the 1991 ADA Standards went into effect (1/26/93)? [404.2.5, 303.2] Note: The first ¼ inch of the ½ or ¾ inch threshold may be vertical; the rest must be beveled.</p>	<p><input type="checkbox"/> Yes <input type="checkbox"/> No Measurement: NA <input type="checkbox"/> Yes <input type="checkbox"/> No Measurement: NA <input type="checkbox"/> Yes <input type="checkbox"/> No Measurement: NA</p>		<p>Photo #:</p>	<ul style="list-style-type: none"> • Remove or replace threshold • •

<p>3.9 Is the door equipped with hardware that is operable with one hand and does not require tight grasping, pinching or twisting of the wrist? Door handle? Lock (if provided)? [404.2.7]</p>	<p><input checked="" type="checkbox"/> Yes <input type="checkbox"/> No <input checked="" type="checkbox"/> Yes <input type="checkbox"/> No <input checked="" type="checkbox"/> Yes <input type="checkbox"/> No</p>		<p>Photo #:</p>	<ul style="list-style-type: none"> • Replace inaccessible knob with lever, loop or push hardware • Add automatic door opener
<p>3.10 Are the operable parts of the door hardware mounted no less than 34 inches and no greater than 48 inches above the floor? [404.2.7]</p>	<p><input checked="" type="checkbox"/> Yes <input type="checkbox"/> No Measurement: 38"</p>		<p>Photo #:</p>	<ul style="list-style-type: none"> • Change hardware height
<p>3.11 Can the door be opened easily (5 pounds maximum force)? [404.2.9] Note: You can use a pressure gauge or fish scale to measure force. If you do not have one you will need to judge whether the door is easy to open.</p>	<p><input type="checkbox"/> Yes <input checked="" type="checkbox"/> No Measurement: 8 LBS</p>		<p>Photo #:</p>	<ul style="list-style-type: none"> • Adjust or replace closers • Install lighter doors • Install power-assisted or automatic door openers
<p>3.12 If the door has a closer, does it take at least 5 seconds to close from an open position of 90 degrees to a position of 12 degrees from the latch? [404.2.8.1]</p>	<p><input checked="" type="checkbox"/> Yes <input type="checkbox"/> No Measurement: 5 SEC</p>		<p>Photo #:</p>	<ul style="list-style-type: none"> • Adjust closer

<p>3.13 If there are two doors in a series, e.g. vestibule, is the distance between the doors at least 48 inches plus the width of the doors when swinging into the space? [404.2.6]</p> <p style="text-align: right;"><i>NA</i></p>	<p><input type="checkbox"/> Yes <input type="checkbox"/> No</p> <p>Measurement:</p> <p style="text-align: center;"><i>NA</i></p>	<p style="text-align: center;">48" min</p> <p style="text-align: center;">or</p> <p style="text-align: center;">48" min</p> <p style="text-align: center;">or</p> <p style="text-align: center;">48" min</p>	<p>Photo #:</p>	<ul style="list-style-type: none"> • Remove inner door • Change door swing •
<p>3.14 If there is a privacy wall and the door swings out, is there at least 24 inches of maneuvering clearance beyond the door latch side and 42 inches to the privacy wall? [404.2.4]</p> <p style="text-align: right;"><i>NA</i></p>	<p><input type="checkbox"/> Yes <input type="checkbox"/> No</p> <p>Measurement:</p> <p style="text-align: center;"><i>NA</i></p>	<p style="text-align: center;">24" min</p> <p style="text-align: center;">48" min</p> <p style="text-align: center;">42" min</p> <p style="text-align: center;">privacy wall</p>	<p>Photo #:</p>	<ul style="list-style-type: none"> • Reconfigure space • •

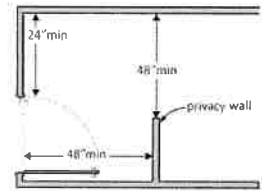
<p>3.15 If there is a privacy wall and the door swings in, is there at least 24 inches of maneuvering clearance beyond the door latch side and at least 48 inches to the privacy wall if there is no door closer or at least 54 inches if there is a door closer? [404.2.4]</p>	<p><input type="checkbox"/> Yes <input type="checkbox"/> No</p> <p>Measurement:</p> <p><i>NA</i></p>		<p>Photo #:</p>	<ul style="list-style-type: none"> • Reconfigure space • •
----------------------------------------------------------------------------------------------------------------------------------------------------------------------------------------------------------------------------------------------------------------------------------------	------------------------------------------------------------------------------------------------------	-----------------------------------------------------------------------------------	-----------------	---------------------------------------------------------------------------------------------

In the Toilet Room

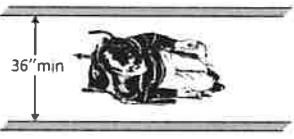
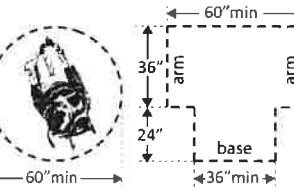
<p>3.16 Is there a clear path to at least one of each type of fixture, e.g. lavatory, hand dryer, etc., that is at least 36 inches wide? [403.5.1]</p>	<p><input checked="" type="checkbox"/> Yes <input type="checkbox"/> No</p> <p>Measurement:</p> <p><i>90"</i></p>		<p>Photo #:</p>	<ul style="list-style-type: none"> • Remove obstructions • •
<p>3.17 Is there clear floor space available for a person in a wheelchair to turn around, i.e. a circle at least 60 inches in diameter or a T-shaped space within a 60-inch square? [603.2.1]</p>	<p><input checked="" type="checkbox"/> Yes <input type="checkbox"/> No</p> <p>Measurement:</p> <p><i>+ 60"</i></p>		<p>Photo #:</p>	<ul style="list-style-type: none"> • Move or remove partitions, fixtures or objects such as trash cans • •

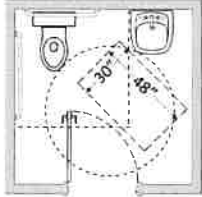
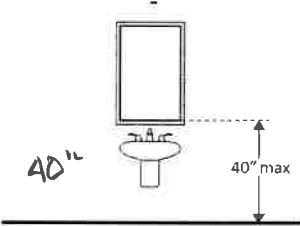
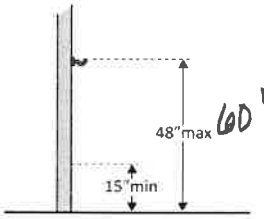
<p>3.18 In a single user toilet room if the door swings in and over a clear floor space at an accessible fixture, is there a clear floor space at least 30 x 48 inches beyond the swing of the door? [603.2.3 Exception 2]</p>	<p><input checked="" type="checkbox"/> Yes <input type="checkbox"/> No Measurement: N/A</p>		<p>Photo #:</p>	<ul style="list-style-type: none"> • Reverse door swing • Alter toilet room •
<p>3.19 If the mirror is over a lavatory or countertop, is the bottom edge of the reflecting surface no higher than 40 inches above the floor? Or If the mirror is not over the lavatory or countertop, is the bottom edge of the reflecting surface no higher than 35 inches above the floor?*[603.3]</p>	<p><input checked="" type="checkbox"/> Yes <input type="checkbox"/> No Measurement: 40" <input type="checkbox"/> Yes <input type="checkbox"/> No Measurement: N/A</p>		<p>Photo #:</p>	<ul style="list-style-type: none"> * If installed before 3/15/2012 and the bottom edge of the reflecting surface is no higher than 40 inches above the floor, lowering the mirror to 35 inches is not required • Lower the mirror • Add another mirror •
<p>3.20 If there is a coat hook, is it no less than 15 inches and no greater than 48 inches above the floor?*[603.4]</p>	<p><input type="checkbox"/> Yes <input checked="" type="checkbox"/> No Measurement: 60"</p>		<p>Photo #:</p>	<ul style="list-style-type: none"> • Adjust hook • Replace with or provide additional accessible hook • * If installed before 3/15/2010 and the clear floor space allows a parallel approach, the coat hook may be 54 inches above the floor.

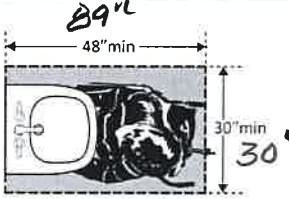
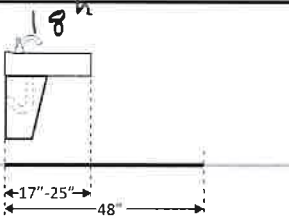
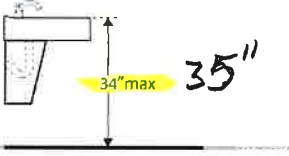
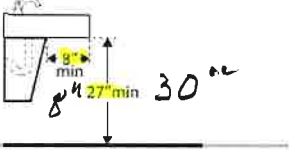
Lavatories The 2010 Standards refer to sinks in toilet rooms as lavatories.				
<p>3.21 Does at least one lavatory have a clear floor space for a forward approach at least 30 inches wide and 48 inches long? [606.2]</p>	<p><input checked="" type="checkbox"/> Yes <input type="checkbox"/> No Measurement: 30" 48"</p>		<p>Photo #:</p>	<ul style="list-style-type: none"> • Alter lavatory • Replace lavatory
<p>3.22 Do no less than 17 inches and no greater than 25 inches of the clear floor space extend under the lavatory so that a person using a wheelchair can get close enough to reach the faucet? [306.2]</p>	<p><input checked="" type="checkbox"/> Yes <input type="checkbox"/> No Measurement: 18" +48"</p>		<p>Photo #:</p>	<ul style="list-style-type: none"> • Alter lavatory • Replace lavatory
<p>3.23 Is the front of the lavatory or counter surface, whichever is higher, no more than 34 inches above the floor? [606.3]</p>	<p><input type="checkbox"/> Yes <input checked="" type="checkbox"/> No Measurement: 35"</p>		<p>Photo #:</p>	<ul style="list-style-type: none"> • Alter lavatory • Replace lavatory
<p>3.24 Is there at least 27 inches clearance from the floor to the bottom of the lavatory that extends at least 8 inches under the lavatory for knee clearance? [306.3.3]</p>	<p><input checked="" type="checkbox"/> Yes <input type="checkbox"/> No Measurement: 8" 30"</p>		<p>Photo #:</p>	<ul style="list-style-type: none"> • Alter lavatory • Replace lavatory

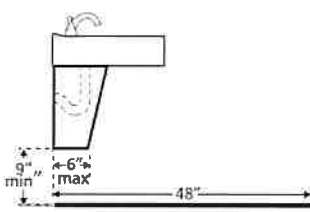
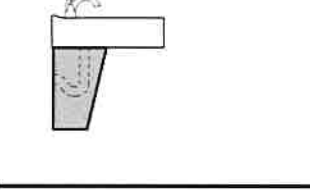
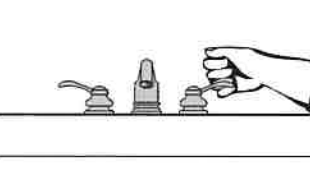
<p>3.25 Is there toe clearance at least 9 inches high? [306.3.3]</p> <p>Note: Space extending greater than 6 inches beyond the available toe clearance at 9 inches above the floor is not considered toe clearance.</p>	<p><input checked="" type="checkbox"/> Yes <input type="checkbox"/> No</p>		<p>Photo #:</p>	<ul style="list-style-type: none"> • Alter lavatory • Replace lavatory •
<p>3.26 Are pipes below the lavatory insulated or otherwise configured to protect against contact? [606.5]</p>	<p><input checked="" type="checkbox"/> Yes <input type="checkbox"/> No</p>		<p>Photo #:</p>	<ul style="list-style-type: none"> • Install insulation • Install cover panel •
<p>3.27 Can the faucet be operated without tight grasping, pinching, or twisting of the wrist?</p> <p>Is the force required to activate the faucet no greater than 5 pounds? [606.4]</p>	<p><input checked="" type="checkbox"/> Yes <input type="checkbox"/> No</p> <p><input checked="" type="checkbox"/> Yes <input type="checkbox"/> No</p>		<p>Photo #:</p>	<ul style="list-style-type: none"> • Adjust faucet • Replace faucet •

Soap Dispensers and Hand Dryers

ADA Checklist for Existing Facilities

Priority 3 – Toilet Rooms

3.28 Are the operable parts of the soap dispenser within one of the following reach ranges:

Above lavatories or counters no less than 20 inches and no greater than 25 inches deep: no higher than 44 inches above the floor?
[308.2.2]

Yes No

Measurement:
17"
44"

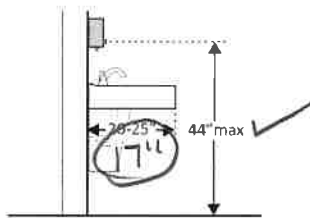

Above lavatories less than 20 inches deep: no higher than 48 inches above the floor?

Yes No

Measurement:
17"
44"

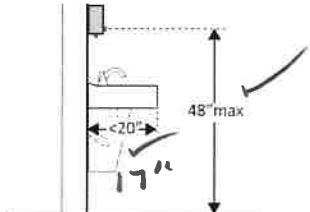

Not over an obstruction: no higher than 48 inches above the floor?
[308.2]

Yes No

Measurement:

48"

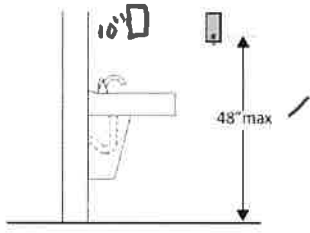
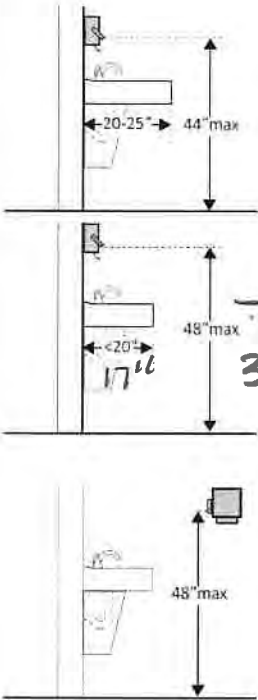

Photo #:

- Adjust dispensers
- Replace with or provide additional accessible dispensers
-

<p>3.29 Are the operable parts of the hand dryer or towel dispenser within one of the following reach ranges:</p> <p>Above lavatories or counters no less than 20 inches and no greater than 25 inches deep: no higher than 44 inches above the floor? <input type="checkbox"/> Yes <input type="checkbox"/> No</p> <p>Measurement: 41"</p> <p>Above lavatories less than 20 inches deep: no higher than 48 inches above the floor? <input checked="" type="checkbox"/> Yes <input type="checkbox"/> No</p> <p>Measurement: 17"</p> <p>Not over an obstruction: no higher than 48 inches above the floor? <input type="checkbox"/> Yes <input type="checkbox"/> No</p> <p>Measurement: 34"</p> <p>Can the operable parts of the hand dryer or towel dispenser be operated without tight grasping, pinching or twisting of the wrist? <input checked="" type="checkbox"/> Yes <input type="checkbox"/> No</p> <p>Is the force required to activate the hand dryer or towel dispenser no greater than 5 pounds? <input type="checkbox"/> Yes <input type="checkbox"/> No</p> <p>Measurement: NA</p> <p>[308.2]</p> <p>[309.4]</p>		<p>Photo #:</p>	<ul style="list-style-type: none"> • Adjust dispensers • Replace with or provide additional accessible dispensers
----------------------------------------------------------------------------------------------------------------------------------------------------------------------------------------------------------------------------------------------------------------------------------------------------------------------------------------------------------------------------------------------------------------------------------------------------------------------------------------------------------------------------------------------------------------------------------------------------------------------------------------------------------------------------------------------------------------------------------------------------------------------------------------------------------------------------------------------------------------------------------------------------------------------------------------------------------------------------------------------------------------------------------------------------------------------------------------------------------------------------------------	------------------------------------------------------------------------------------	-----------------	-------------------------------------------------------------------------------------------------------------------------------------------

Water Closets in Single-User Toilet Rooms and Compartments (Stalls) The 2010 Standards refer to toilets as water closets.

ADA Checklist for Existing Facilities

Priority 3 – Toilet Rooms

3.30 Is the centerline of the water closet no less than 16 inches and no greater than 18 inches from the side wall or partition? [604.2]

Yes No

Measurement:

17"

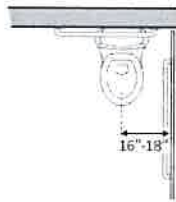

Photo #:

- Move toilet
- Replace toilet
- Move partition
-

3.31 Is clearance provided around the water closet measuring at least 60 inches from the side wall and at least 56 inches from the rear wall?*[604.3.1]

Yes No

Measurement:

56"

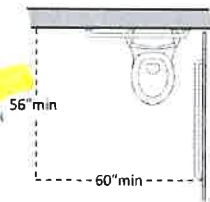



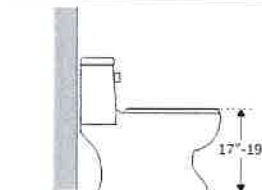
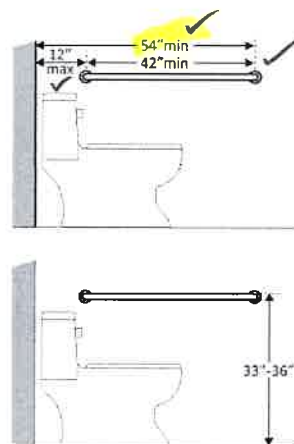

* If constructed before 3/15/12, clearances around water closets in single user toilet rooms can be 48 inches wide by 66 inches long or 48 inches wide by 56 inches long (depending on the approach to the water closet, see 1991 Standards Figure 28) and the lavatory may overlap that clearance if the door to the room does not swing into the required clearances at fixtures (such as lavatories, water closet and urinals) and the edge of the lavatory is at least 18 inches from the centerline of the water closet

- Alter room/compartment for clearance
-
-

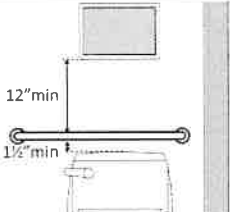
			Photo #:	
<p>3.32 Is the height of the water closet no less than 17 inches and no greater than 19 inches above the floor measured to the top of the seat? [604.4]</p>	<p><input type="checkbox"/> Yes <input checked="" type="checkbox"/> No</p> <p>Measurement: 15"</p>		Photo #:	<ul style="list-style-type: none"> • Adjust toilet height • Replace toilet
<p>3.33 Is there a grab bar at least 42 inches long on the side wall?</p> <p>Is it located no more than 12 inches from the rear wall?</p> <p>Does it extend at least 54 inches from the rear wall? [604.5.1]</p> <p>Is it mounted no less than 33 inches and no greater than 36 inches above the floor to the top of the gripping surface? [609.4]</p> <p>Is there at least 12 inches clearance between the grab bar</p>	<p><input checked="" type="checkbox"/> Yes <input type="checkbox"/> No</p> <p>Measurement: 12"</p> <p><input checked="" type="checkbox"/> Yes <input type="checkbox"/> No</p> <p>Measurement: 34"</p> <p><input checked="" type="checkbox"/> Yes <input type="checkbox"/> No</p>		?	<ul style="list-style-type: none"> • Install grab bar • Relocate grab bar • Relocate objects

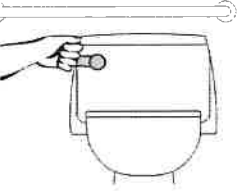
<p>and protruding objects above?*</p> <p>Is there at least 1½ inches clearance between the grab bar and projecting objects below?*</p> <p>Is the space between the wall and the grab bar 1 ½ inches? [609.3]</p>	<p>Measurement:</p> <p><input checked="" type="checkbox"/> Yes <input type="checkbox"/> No</p> <p>Measurement: 6"</p> <p><input checked="" type="checkbox"/> Yes <input type="checkbox"/> No</p> <p>Measurement: 1 ½"</p>		<p>Photo #:</p>	<p>* If constructed before 3/15/2012 grab bars do not need to be relocated; there are no space requirements above and below grab bars in the 1991 Standards</p>
<p>3.34 Is there a grab bar at least 36 inches long on the rear wall?</p> <p>Does it extend at least 12 inches from the centerline of the water closet on one side (side wall)?</p> <p>Does it extend at least 24 inches on the other (open) side? [604.5.2]</p> <p>Is it mounted no less than 33 inches and no greater than 36 inches above the floor to the top of the gripping surface? [609.4]</p> <p>Are there at least 12 inches clearance between the grab bar and protruding objects above?*</p> <p>Are there at least 1½ inches</p>	<p><input checked="" type="checkbox"/> Yes <input type="checkbox"/> No</p> <p>Measurement: 36"</p> <p><input checked="" type="checkbox"/> Yes <input type="checkbox"/> No</p> <p>Measurement: 12"</p> <p><input checked="" type="checkbox"/> Yes <input type="checkbox"/> No</p> <p>Measurement: 24"</p> <p><input checked="" type="checkbox"/> Yes <input type="checkbox"/> No</p> <p>Measurement: 34"</p> <p><input type="checkbox"/> Yes <input type="checkbox"/> No</p> <p>Measurement: NA</p> <p><input checked="" type="checkbox"/> Yes <input type="checkbox"/> No</p>		<p>Photo #:</p>	<ul style="list-style-type: none"> • Install grab bar • Relocate grab bar • Relocate objects <p>* If constructed before 3/15/2012 grab bars do not need to be relocated; there are no space</p>

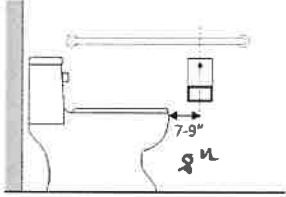
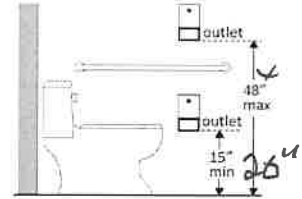
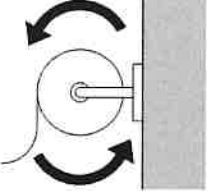

<p>clearance between the grab bar and projecting objects below?*</p> <p>Is the space between the wall and the grab bar 1½ inches? [609.3]</p>	<p>Measurement: 6"</p> <p><input checked="" type="checkbox"/> Yes <input type="checkbox"/> No</p> <p>Measurement: 1½"</p>		<p>Photo #:</p>	<p>requirements above and below grab bars in the 1991 Standards</p>
<p>3.35 If the flush control is hand operated, is the operable part located no higher than 48 inches above the floor? [604.6]</p>	<p><input checked="" type="checkbox"/> Yes <input type="checkbox"/> No</p> <p>Measurement: 24"</p>		<p>Photo #:</p>	<ul style="list-style-type: none"> • Move control • Install sensor with override button no higher than 48 inches •
<p>3.36 If the flush control is hand operated, can it be operated with one hand and without tight grasping, pinching, or twisting of the wrist?</p> <p>Is the force required to activate the flush control no greater than 5 pounds? [605.4]</p>	<p><input checked="" type="checkbox"/> Yes <input type="checkbox"/> No</p> <p><input checked="" type="checkbox"/> Yes <input type="checkbox"/> No</p> <p>Measurement:</p>		<p>Photo #:</p>	<ul style="list-style-type: none"> • Change control • Adjust control •
<p>3.37 Is the flush control on the open side of the water closet? [604.6]</p>	<p><input checked="" type="checkbox"/> Yes <input type="checkbox"/> No</p>		<p>Photo #:</p>	<ul style="list-style-type: none"> • Move control • •

<p>3.38 Is the toilet paper dispenser located no less than 7 inches and no greater than 9 inches from the front of the water closet to the centerline of the dispenser?*</p> <p>[604.7]</p>	<p><input checked="" type="checkbox"/> Yes <input type="checkbox"/> No</p> <p>Measurement:</p> <p>8" u</p>		<p>Photo #:</p>	<p>* If constructed before 3/15/2012 dispenser does not need to be relocated if it is within reach from the water closet seat; the 1991 Standards do not specify distance from the front of the water closet</p> <ul style="list-style-type: none"> • Relocate dispenser • •
<p>3.39 Is the outlet of the dispenser:</p> <p>Located no less than 15 inches and no greater than 48 inches above the floor?</p> <p>Not located behind grab bars?</p> <p>[604.7]</p>	<p><input checked="" type="checkbox"/> Yes <input type="checkbox"/> No</p> <p>Measurement:</p> <p>20" u</p> <p><input checked="" type="checkbox"/> Yes <input type="checkbox"/> No</p>		<p>Photo #:</p>	<ul style="list-style-type: none"> • Relocate dispenser • •
<p>3.40 Does the dispenser allow continuous paper flow?</p> <p>[604.7]</p>	<p><input checked="" type="checkbox"/> Yes <input type="checkbox"/> No</p>		<p>Photo #:</p>	<ul style="list-style-type: none"> • Adjust dispenser • Replace dispenser •

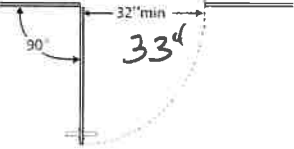
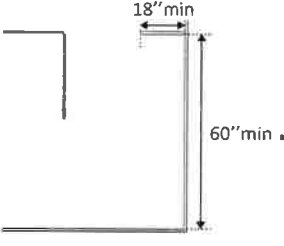

Toilet Compartments (Stalls)

ADA Checklist for Existing Facilities

Priority 3 – Toilet Rooms

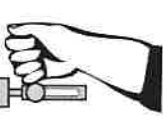
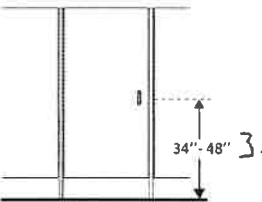
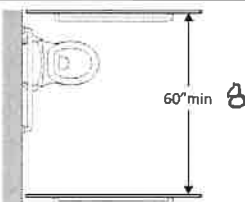
<p>3.41 Is the door opening width at least 32 inches clear, between the face of the door and the stop, when the door is open 90 degrees? [604.8.1.2]</p>	<p><input checked="" type="checkbox"/> Yes <input type="checkbox"/> No Measurement: 33"</p>	 <p>A schematic diagram showing a door frame with a 90-degree arc of movement. A horizontal dimension line indicates a measurement of 33 inches from the door face to the stop.</p>	<p>Photo #:</p>	<ul style="list-style-type: none"> • Widen door width • •
<p>3.42 If there is a front approach to the pull side of the door, is there at least 18 inches of maneuvering clearance beyond the latch side plus 60 inches clear depth? [604.8.1.2]</p> <p>Note: See 2010 Standards 604.8.1.2 Doors for maneuvering clearance requirements on the push side of the door and side approaches to the pull side of the door</p>	<p><input checked="" type="checkbox"/> Yes <input type="checkbox"/> No Measurement: 60"</p>	 <p>A schematic diagram of a door with a pull handle. It shows a 18-inch maneuvering clearance beyond the latch side and a 60-inch clear depth.</p>	<p>Photo #:</p>	<ul style="list-style-type: none"> • Remove obstructions • •
<p>3.43 Is the door self-closing? [604.8.1.2]</p>	<p><input checked="" type="checkbox"/> Yes <input type="checkbox"/> No</p>	 <p>A schematic diagram of a door with a curved arrow indicating it is self-closing.</p>	<p>Photo #:</p>	<ul style="list-style-type: none"> • Add closer • Replace door •

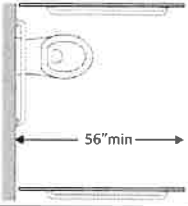
<p>3.44 Are there door pulls on both sides of the door that are operable with one hand and do not require tight grasping pinching or twisting of the wrist?*</p> <p>[604.8.1.2]</p>	<p><input type="checkbox"/> Yes <input checked="" type="checkbox"/> No</p>		<p>Photo #:</p>	<p>* If constructed before 3/15/2012 door pulls do not need to be added; door pulls are not required in the 1991 Standards</p> <ul style="list-style-type: none"> • Replace hardware • •
<p>3.45 Is the lock operable with one hand and without tight grasping, pinching or twisting of the wrist?</p> <p>[309.4]</p>	<p><input checked="" type="checkbox"/> Yes <input type="checkbox"/> No</p>		<p>Photo #:</p>	<ul style="list-style-type: none"> • Replace lock • •
<p>3.46 Are the operable parts of the door hardware mounted no less than 34 inches and no greater than 48 inches above the floor?</p> <p>[404.2.7]</p>	<p><input checked="" type="checkbox"/> Yes <input type="checkbox"/> No</p> <p>Measurement: 38"</p>		<p>Photo #:</p>	<ul style="list-style-type: none"> • Relocate hardware • •
<p>3.47 Is the compartment at least 60 inches wide?</p> <p>[604.8.1.1]</p>	<p><input checked="" type="checkbox"/> Yes <input type="checkbox"/> No</p> <p>Measurement: 89"</p>		<p>Photo #:</p>	<ul style="list-style-type: none"> • Widen compartment • •

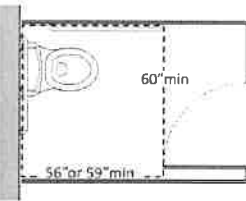
<p>3.48 If the water closet is wall hung, is the compartment at least 56 inches deep? [604.8.1.1]</p>	<p><input checked="" type="checkbox"/> Yes <input type="checkbox"/> No Measurement: +56"</p>		<p>Photo #:</p>	<ul style="list-style-type: none"> • Widen compartment • •
<p>3.49 If the water closet is floor mounted, is the compartment at least 59 inches deep? [604.8.1.1]</p>	<p><input checked="" type="checkbox"/> Yes <input type="checkbox"/> No Measurement: +56"</p>		<p>Photo #:</p>	<ul style="list-style-type: none"> • Alter compartment • •
<p>3.50 If the door swings in, is the minimum required compartment area provided beyond the swing of the door (60 inches x 56 inches if water closet is wall hung or 59 inches if water closet is floor mounted)? [604.8.1.1]</p>	<p><input type="checkbox"/> Yes <input type="checkbox"/> No Measurement: NA</p>		<p>SWINGS OUT</p> <p>Photo #:</p>	<ul style="list-style-type: none"> • Reverse door swing • Alter compartment •

ADA Checklist for Existing Facilities

Priority 4 – Additional Access

Based on the 2010 ADA Standards for Accessible Design

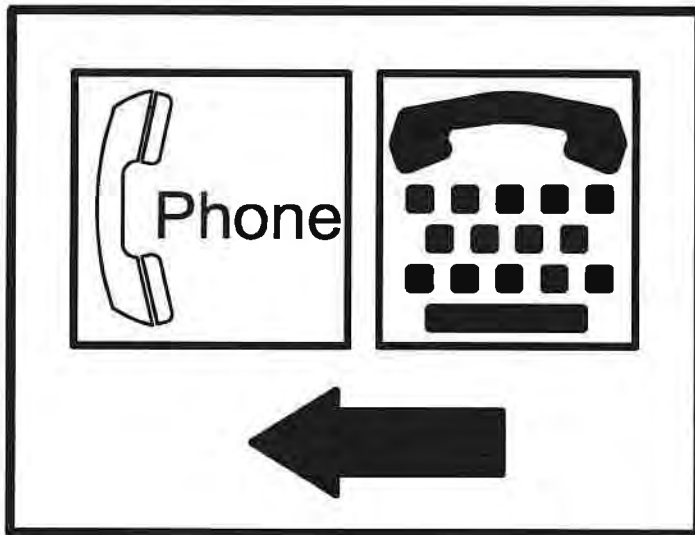

Project ADA TRANSITION PLAN

Building FIRE DEPARTMENT

Location WEAVER H.C.

Date 4-20-2020

Surveyors ALAN F. MACKAY

Contact Information KYLE DAVIS

Amenities such as drinking fountains and public telephones should be accessible to people with disabilities.



Institute for Human Centered Design
www.HumanCenteredDesign.org
Copyright © 2016



ADA National Network
Questions on the ADA 800-949-4232 voice/tty
www.ADAchecklist.org



This checklist was produced by the New England ADA Center, a project of the Institute for Human Centered Design and a member of the ADA National Network. This checklist was developed under a grant from the Department of Education, NIDRR grant number H133A060092-09A. However the contents do not necessarily represent the policy of the Department of Education, and you should not assume endorsement by the Federal Government.

Questions or comments on the checklist contact the New England ADA Center at 617-695-0085 voice/tty or ADAinfo@NewEnglandADA.org

For the full set of checklists, including the checklists for recreation facilities visit www.ADAchecklist.org.

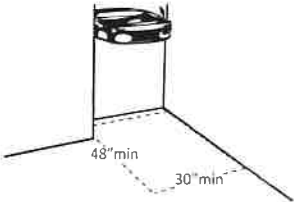
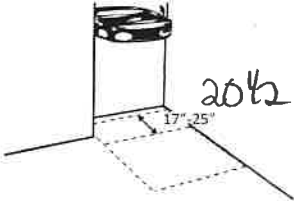
Copyright © 2016 ADA Checklist for Existing Materials. You can freely reproduce and distribute this content. Include proper attribution. But you must get permission before using this content as a fee-based product.

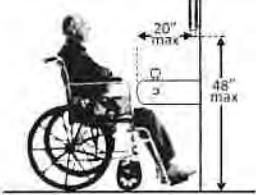
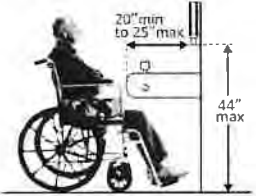

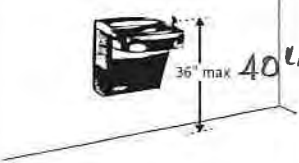

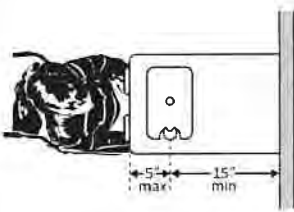
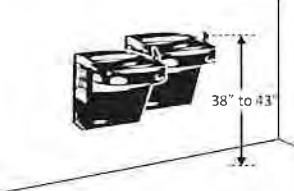
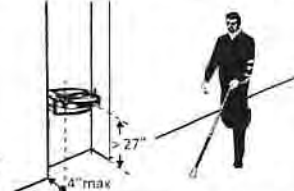
Priority 4 – Additional Access		Comments	Possible Solutions
Drinking Fountains			
<p>4.1 Does at least one drinking fountain have a clear floor space at least 30 inches wide x at least 48 inches long centered in front of it for a forward approach?*</p> <p>[See 2010 ADA Standards for Accessible Design – 602.2]</p>	<p><input checked="" type="checkbox"/> Yes <input type="checkbox"/> No</p> <p>Measurement:</p> <p>+30" x +48"</p>		<p>Photo #:</p> <p>*If installed before 3/15/2012, a parallel approach is permitted and the clear floor space is not required to be centered</p> <ul style="list-style-type: none"> • Alter space • Relocate drinking fountain • Install a drinking fountain in another location
<p>4.2 If there is a forward approach, do no less than 17 inches and no greater than 25 inches of the clear floor space extend under the drinking fountain?</p> <p>[306.2.2, 306.2.3]</p> <p>Note: If the drinking fountain is primarily for children's use and the spout is no more than 30 inches above the floor and no more than 3 1/2 inches from the edge of the unit, a parallel approach is permitted.</p>	<p><input checked="" type="checkbox"/> Yes <input type="checkbox"/> No</p> <p>Measurement:</p> <p>20 1/2"</p>		<p>Photo #:</p> <ul style="list-style-type: none"> • Alter space • Replace drinking fountain •

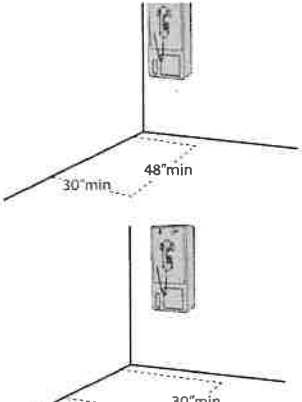
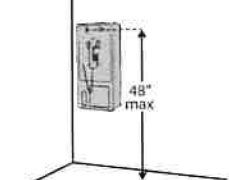
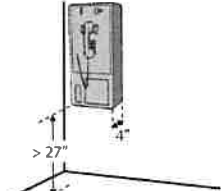

<p>4.3 If the drinking fountain is no deeper than 20 inches, are the operable parts no higher than 48 inches above the floor? [308.2.2]</p>	<p><input checked="" type="checkbox"/> Yes <input type="checkbox"/> No Measurement: 19"</p>		<p>Photo #:</p>	<ul style="list-style-type: none"> • Adjust drinking fountain • Replace drinking fountain
<p>4.4 If the drinking fountain is no less than 20 inches and no greater than 25 inches deep, are the operable parts no higher than 44 inches above the floor? [308.2.2]</p>	<p><input type="checkbox"/> Yes <input type="checkbox"/> No Measurement: 19"</p>		<p>Photo #:</p>	<ul style="list-style-type: none"> • Adjust drinking fountain • Replace drinking fountain
<p>4.5 Can the control be operated with one hand and without tight grasping, pinching or twisting of the wrist? Is the force required to activate the control no more than 5 pounds? [309.4]</p>	<p><input checked="" type="checkbox"/> Yes <input type="checkbox"/> No <input type="checkbox"/> Yes <input checked="" type="checkbox"/> No Measurement: NA</p>		<p>Photo #:</p>	<ul style="list-style-type: none"> • Change control • Adjust control
<p>4.6 Is the spout outlet no higher than 36 inches above the floor? [602.4]</p>	<p><input type="checkbox"/> Yes <input checked="" type="checkbox"/> No Measurement: 40"</p>		<p>Photo #:</p>	<ul style="list-style-type: none"> • Adjust drinking fountain • Replace drinking fountain

<p>4.7 Is the spout:</p> <p>At least 15 inches from the rear of the drinking fountain?</p> <p>No more than 5 inches from the front of the drinking fountain? [602.5]</p>	<p><input checked="" type="checkbox"/> Yes <input type="checkbox"/> No</p> <p>Measurement: 16"</p> <p><input checked="" type="checkbox"/> Yes <input type="checkbox"/> No</p> <p>Measurement: 2"</p>		<p>Photo #:</p>	<ul style="list-style-type: none"> • Adjust spout • Replace drinking fountain •
<p>4.8 If there is more than one drinking fountain, is there at least one for standing persons? [211.2]</p> <p>Is the spout outlet no lower than 38 inches and no higher than 43 inches above the floor? [602.7]</p>	<p><input checked="" type="checkbox"/> Yes <input type="checkbox"/> No</p> <p><input type="checkbox"/> Yes <input type="checkbox"/> No</p> <p>Measurement: 38"</p>		<p>Photo #:</p>	<ul style="list-style-type: none"> • Adjust drinking fountain • Install new drinking fountain for standing height •
<p>4.9 If the leading (bottom) edge of the fountain is higher than 27 inches above the floor, does the front of the fountain protrude no more than 4 inches into the circulation path? [307.2]</p>	<p><input type="checkbox"/> Yes <input type="checkbox"/> No</p> <p>Measurement: NA RECESSED</p>		<p>Photo #:</p>	<ul style="list-style-type: none"> • Adjust drinking fountain • Replace drinking fountain • Add tactile warning such as permanent planter or partial walls

NA

Public Telephones				
<p>4.10 Does at least one telephone have a clear floor space at least 30 inches wide x at least 48 inches long for a parallel or forward approach? [704.2.1]</p>	<p><input type="checkbox"/> Yes <input type="checkbox"/> No</p> <p>NA</p>		<p>Photo #:</p>	<ul style="list-style-type: none"> • Move telephone • Install new telephone for clear floor space
<p>4.11 Is the highest operable part of the telephone no higher than 48 inches above the floor? [704.2.2]</p>	<p><input type="checkbox"/> Yes <input type="checkbox"/> No</p> <p>Measurement:</p> <p>NA</p>		<p>Photo #:</p>	<ul style="list-style-type: none"> • Adjust telephone
<p>4.12 If the leading (bottom) edge of the telephone is higher than 27 inches above the floor, does the front of the telephone protrude no more than 4 inches into the circulation path? [307.2]</p>	<p><input type="checkbox"/> Yes <input type="checkbox"/> No</p> <p>Measurement:</p> <p>NA</p>		<p>Photo #:</p>	<ul style="list-style-type: none"> • Adjust telephone

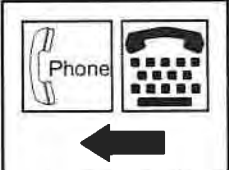
<p>4.13 Does at least one telephone have a volume control? [704.3]</p>	<p><input type="checkbox"/> Yes <input type="checkbox"/> No</p> <p>NA</p>		<p>Photo #:</p>	<ul style="list-style-type: none"> • Install volume control • Replace telephone with one that has volume control •
<p>4.14 Is the volume control identified by a pictogram of a telephone handset with radiating sound waves? [703.7.2.3]</p>	<p><input type="checkbox"/> Yes <input type="checkbox"/> No</p> <p>NA</p>		<p>Photo #:</p>	<ul style="list-style-type: none"> • Add pictogram • •
<p>4.15 Does at least one telephone have a TTY? [217.4.1]</p> <p>Note: TTY's are devices that employ interactive text-based communication through the transmission of coded signals across the telephone network. They are mainly used by people who are deaf and/or cannot speak.</p>	<p><input type="checkbox"/> Yes <input type="checkbox"/> No</p> <p>NA</p>		<p>Photo #:</p>	<ul style="list-style-type: none"> • Install TTY • •
<p>4.16 Is the touch surface of the TTY keypad at least 34 inches above the floor? [704.4.1]</p> <p>Note: If a seat is provided, the TTY is not required to be 34 inches minimum above the floor.</p>	<p><input type="checkbox"/> Yes <input type="checkbox"/> No</p> <p>Measurement:</p> <p>NA</p>		<p>Photo #:</p>	<ul style="list-style-type: none"> • Adjust height of TTY • •

<p>4.17 Is the TTY identified by the International Symbol of TTY? [703.7.2.2]</p>	<p><input type="checkbox"/> Yes <input type="checkbox"/> No</p> <p>NA</p>		<p>Photo #:</p>	<ul style="list-style-type: none"> • Add symbol • •
<p>4.18 Do signs that provide direction to public telephones also provide direction to the TTY? [216.9.2]</p>	<p><input type="checkbox"/> Yes <input type="checkbox"/> No</p> <p>NA</p>		<p>Photo #:</p>	<ul style="list-style-type: none"> • Add signs • •
<p>4.19 Do telephones that do not have a TTY provide direction to the TTY? [216.9.2]</p>	<p><input type="checkbox"/> Yes <input type="checkbox"/> No</p> <p>NA</p>		<p>Photo #:</p>	<ul style="list-style-type: none"> • Add signs • •
<p>Fire Alarm Systems</p>				
<p>4.20 If there are fire alarm systems, do they have both flashing lights and audible signals? [702.1]</p>	<p><input checked="" type="checkbox"/> Yes <input type="checkbox"/> No</p>		<p>Photo #:</p>	<ul style="list-style-type: none"> • Install audible and visual alarms • •



TOWN OF WEAVERVILLE

APPENDIX C.3:

Public Works Building

ADA TRANSITION PLAN

ADA Checklist for Existing Facilities

Priority 1 – Approach & Entrance

Based on the 2010 ADA Standards for Accessible Design

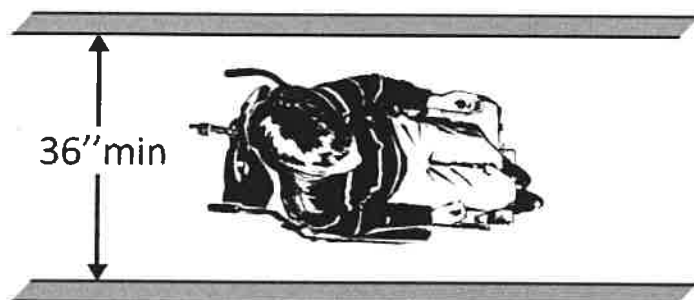

Project ADA TRANSITION PLAN

Building PUBLIC WORKS BUILDING

Location WEAVERVILLE N.C.

Date 4-20-2020

Surveyors ALAN F. MACKAY

Contact Information DALE PENNELL

An accessible route from site arrival points and an accessible entrance should be provided for everyone.



Institute for Human Centered Design
www.HumanCenteredDesign.org
Copyright © 2016



ADA National Network
Questions on the ADA 800-949-4232 voice/tty
www.ADAchecklist.org

This checklist was produced by the New England ADA Center, a project of the Institute for Human Centered Design and a member of the ADA National Network. This checklist was developed under a grant from the Department of Education, NIDRR grant number H133A060092-09A. However the contents do not necessarily represent the policy of the Department of Education, and you should not assume endorsement by the Federal Government.

Questions or comments on the checklist contact the New England ADA Center at 617-695-0085 voice/tty or ADAinfo@NewEnglandADA.org



For the full set of checklists, including the checklists for recreation facilities visit www.ADAchecklist.org.

Copyright © 2016 ADA Checklist for Existing Materials. You can freely reproduce and distribute this content. Include proper attribution. But you must get permission before using this content as a fee-based product.

Priority 1 – Approach & Entrance		Comments	Possible Solutions												
<p>1.1 Is there at least one route from site arrival points (parking, passenger loading zones, public sidewalks and public transportation stops) that does not require the use of stairs? [See 2010 ADA Standards for Accessible Design – 206.2.1]</p>	<p><input checked="" type="checkbox"/> Yes <input type="checkbox"/> No</p> <p>If yes, location of route:</p>	<p>TO PUBLIC WORKS ENTRANCE</p>	<p>• Add a ramp</p> <p>• Regrade to 1:20 maximum slope</p> <p>• Add a lift if site constraints prevent other solutions</p>												
<p>Parking Accessible parking spaces should be identified by size, access aisle and signage.</p>															
<p>1.2 If parking is provided for the public, are an adequate number of accessible spaces provided? [208.2]</p>	<p><input checked="" type="checkbox"/> Yes <input type="checkbox"/> No</p> <p>Total #: 29</p> <p>Accessible #: 2</p>	<table border="1"> <thead> <tr> <th>Total Spaces</th> <th>Accessible Spaces</th> </tr> </thead> <tbody> <tr> <td>1 - 25</td> <td>1</td> </tr> <tr> <td>26 - 50</td> <td>2 ✓</td> </tr> <tr> <td>51 - 75</td> <td>3</td> </tr> <tr> <td>76 - 100</td> <td>4</td> </tr> <tr> <td colspan="2">100+ see 2010 Standards 208.2</td> </tr> </tbody> </table>	Total Spaces	Accessible Spaces	1 - 25	1	26 - 50	2 ✓	51 - 75	3	76 - 100	4	100+ see 2010 Standards 208.2		<p>• Reconfigure by repainting lines</p> <p>•</p> <p>•</p>
Total Spaces	Accessible Spaces														
1 - 25	1														
26 - 50	2 ✓														
51 - 75	3														
76 - 100	4														
100+ see 2010 Standards 208.2															
<p>1.3 Of the accessible spaces, is at least one a van accessible space?*[208.2.4]</p>	<p><input checked="" type="checkbox"/> Yes <input type="checkbox"/> No</p>	<p>*For every 6 or fraction of 6 parking spaces required by the table above, at least 1 should be a van accessible space.</p>	<p>* If constructed before 3/15/2012, parking is compliant if at least 1 in every 8 accessible spaces is van accessible</p> <p>• Reconfigure by repainting lines</p>												

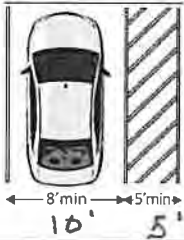
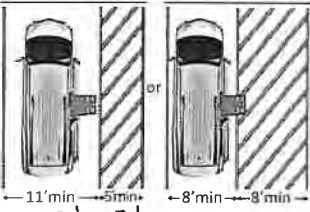

ADA Checklist for Existing Facilities

Priority 1 – Approach & Entrance

<p>1.4 Are accessible spaces at least 8 feet wide with an access aisle at least 5 feet wide? [502.2, 502.3]</p> <p>Note: Two spaces may share an access aisle. Check state/local requirements; some specify that each space have its own aisle.</p>	<p><input checked="" type="checkbox"/> Yes <input type="checkbox"/> No</p> <p>Measurement: 10' WIDE 5' WIDE</p>		<p>Photo #:</p>	<ul style="list-style-type: none"> • Reconfigure by repainting lines • •
<p>1.5 Is the van accessible space: At least 11 feet wide with an access aisle at least 5 feet wide? Or At least 8 feet wide with an access aisle at least 8 feet wide? [502.2]</p>	<p><input type="checkbox"/> Yes <input checked="" type="checkbox"/> No</p> <p>Measurement: 10'</p> <p><input type="checkbox"/> Yes <input checked="" type="checkbox"/> No</p> <p>Measurement: 5'</p>		<p>Photo #:</p>	<ul style="list-style-type: none"> • Reconfigure to provide van-accessible space(s) • •
<p>1.6 Is at least 98 inches of vertical clearance provided for the van accessible space? [502.5]</p>	<p><input type="checkbox"/> Yes <input type="checkbox"/> No</p> <p>Measurement: NA</p>		<p>Photo #:</p>	<ul style="list-style-type: none"> • Reconfigure to provide van-accessible space(s) • •

ADA Checklist for Existing Facilities

Priority 1 – Approach & Entrance

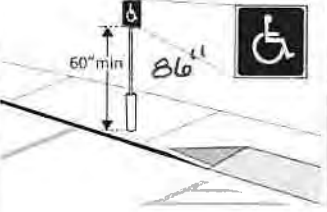

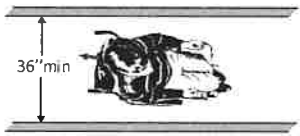
<p>1.7 Are the access aisles marked so as to discourage parking in them? [502.3.3]</p> <p>Note: The marking method and color may be addressed by state/local requirements.</p>	<input checked="" type="checkbox"/> Yes <input type="checkbox"/> No	 <p>area to be marked</p>	<p>Photo #:</p>	<ul style="list-style-type: none"> • Mark access aisles • •
<p>1.8 Is the slope of the accessible parking spaces and access aisles no steeper than 1:48 in all directions? [502.4]</p>	<input type="checkbox"/> Yes <input type="checkbox"/> No Measurement: <i>NA</i>		<p>Photo #:</p>	<ul style="list-style-type: none"> • Regrade surface • •
<p>1.9 Do the access aisles adjoin an accessible route? [502.3]</p>	<input type="checkbox"/> Yes <input type="checkbox"/> No		<p>Photo #:</p>	<ul style="list-style-type: none"> • Create accessible route • Relocate accessible space •
<p>1.10 Are accessible spaces identified with a sign that includes the International Symbol of Accessibility? Is the bottom of the sign at least 60 inches above the ground? [502.6]</p> <p>Note: The International Symbol of Accessibility is not required on the ground.</p>	<input checked="" type="checkbox"/> Yes <input type="checkbox"/> No <input checked="" type="checkbox"/> Yes <input type="checkbox"/> No Measurement: <i>86"</i>		<p>Photo #:</p>	<ul style="list-style-type: none"> • Install signs • •

<p>1.11 Are there signs reading “van accessible” at van accessible spaces? [502.6]</p>	<p><input checked="" type="checkbox"/> Yes <input type="checkbox"/> No</p>		<p>Photo #:</p>	<ul style="list-style-type: none"> • Install signs • •
<p>1.12 Of the total parking spaces, are the accessible spaces located on the closest accessible route to the accessible entrance(s)? [208.3.1]</p> <p>Note: If parking serves multiple entrances, accessible parking should be dispersed.</p>	<p><input checked="" type="checkbox"/> Yes <input type="checkbox"/> No</p>		<p>Photo #:</p>	<ul style="list-style-type: none"> • Reconfigure spaces • •
<p>Exterior Accessible Route</p>				
<p>1.13 Is the route stable, firm and slip-resistant? [302.1]</p>	<p><input checked="" type="checkbox"/> Yes <input type="checkbox"/> No</p>		<p>Photo #:</p>	<ul style="list-style-type: none"> • Repair uneven paving • Fill small bumps and breaks with patches • Replace gravel with asphalt or other surface
<p>1.14 Is the route at least 36 inches wide? [403.5.1]</p>	<p><input checked="" type="checkbox"/> Yes <input type="checkbox"/> No</p> <p>Measurement:</p> <p>51' 60"</p>			<ul style="list-style-type: none"> • Change or move landscaping, furnishings or other items • Widen route •

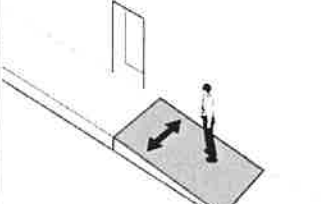
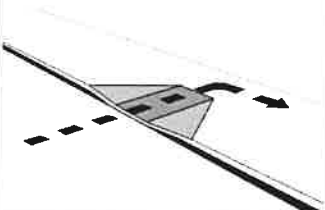
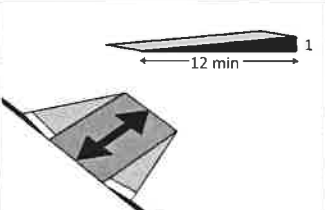
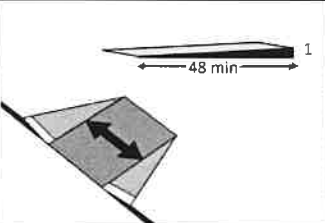
<p>Note: The accessible route can narrow to 32 inches min. for a max. of 24 inches. These narrower portions of the route must be at least 48 inches from each other.</p>			<p>Photo #:</p>	
<p>1.15 If the route is greater than 200 feet in length and less than 60 inches wide, is there a passing space no less than 60 x 60 inches? [403.5.3]</p>	<p><input type="checkbox"/> Yes <input type="checkbox"/> No Measurement: NA</p>		<p>Photo #:</p>	<ul style="list-style-type: none"> • Widen route for passing space • •
<p>1.16 If there are grates or openings on the route, are the openings no larger than 1/2 inches? Is the long dimension perpendicular to the dominant direction of travel? [302.3]</p>	<p><input type="checkbox"/> Yes <input type="checkbox"/> No Measurement: NA <input checked="" type="checkbox"/> Yes <input type="checkbox"/> No</p>		<p>Photo #:</p>	<ul style="list-style-type: none"> • Replace or move grate • •
<p>1.17 Is the running slope no steeper than 1:20, i.e. for every inch of height change there are at least 20 inches of route run? [403.3] Note: If the running slope is steeper than 1:20, treat as a ramp and add features such as edge protection and handrails.</p>	<p><input type="checkbox"/> Yes <input type="checkbox"/> No Measurement:</p>		<p>Photo #:</p>	<ul style="list-style-type: none"> • Regrade to 1:20 max. • •

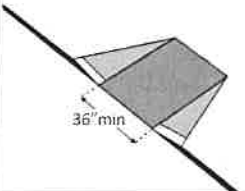
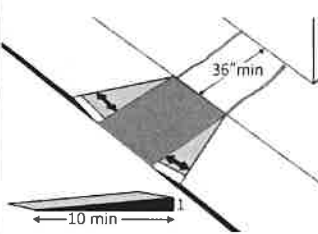
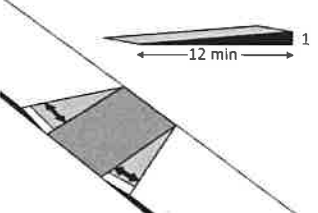
<p>1.18 Is the cross slope no steeper than 1:48? [403.3]</p>	<p><input checked="" type="checkbox"/> Yes <input type="checkbox"/> No</p> <p>Measurement:</p>		<p>Photo #:</p>	<ul style="list-style-type: none"> • Regrade to 1:48 max. • •
<p>Curb Ramps</p>				
<p>1.19 If the accessible route crosses a curb, is there a curb ramp? [402.2]</p>	<p><input checked="" type="checkbox"/> Yes <input type="checkbox"/> No</p>		<p>Photo #:</p>	<ul style="list-style-type: none"> • Install curb ramp • •
<p>1.20 Is the running slope of the curb ramp no steeper than 1:12, i.e. for every inch of height change there are at least 12 inches of curb ramp run? [406.1, 405.2]</p>	<p><input checked="" type="checkbox"/> Yes <input type="checkbox"/> No</p> <p>Measurement:</p>		<p>Photo #:</p>	<ul style="list-style-type: none"> • Regrade curb ramp • •
<p>1.21 Is the cross slope of the curb ramp, excluding flares, no steeper than 1:48? [406.1, 405.3]</p>	<p><input checked="" type="checkbox"/> Yes <input type="checkbox"/> No</p> <p>Measurement:</p>		<p>Photo #:</p>	<ul style="list-style-type: none"> • Regrade curb ramp • •

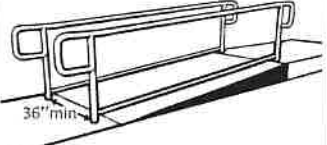

<p>1.22 Is the curb ramp, excluding flares, at least 36 inches wide? [406.1, 405.5]</p>	<p><input checked="" type="checkbox"/> Yes <input type="checkbox"/> No</p> <p>Measurement:</p> <p>5'</p>		<p>Photo #:</p>	<ul style="list-style-type: none"> • Widen curb ramp • •
<p>1.23 At the top of the curb ramp is there a level landing (slope no steeper than 1:48 in all directions) that is at least 36 inches long and at least as wide as the curb ramp? [406.4]</p> <p>If there are curb ramp flares, are the slopes of the flares no steeper than 1:10, i.e. for every inch of height change there are at least 10 inches of flare run? [406.3]</p>	<p><input checked="" type="checkbox"/> Yes <input type="checkbox"/> No</p> <p>Measurement:</p> <p><input type="checkbox"/> Yes <input type="checkbox"/> No</p> <p>Measurement:</p>		<p>Photo #:</p>	<ul style="list-style-type: none"> • Reconfigure • Add ramp flares •
<p>1.24 If the landing at the top is less than 36 inches long, are there curb ramp flares?</p> <p>Are the slopes of the flares no greater than 1:12, i.e. for every inch of height change there are at least 12 inches of flare run? [406.4]</p>	<p><input type="checkbox"/> Yes <input type="checkbox"/> No</p> <p><input type="checkbox"/> Yes <input type="checkbox"/> No</p> <p>Measurement:</p>		<p>Photo #:</p>	<ul style="list-style-type: none"> • Add ramp flares • Regrade flares •

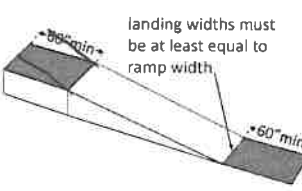
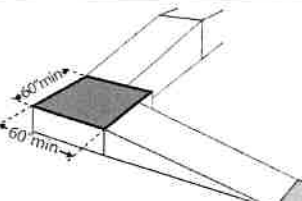
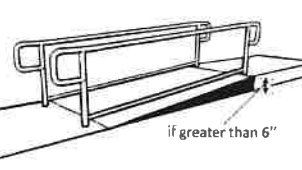
Ramps If any portion of the accessible route is steeper than 1:20, it should be treated as a ramp.				
<p>1.25 If there is a ramp is it at least 36 inches wide? [405.5]</p> <p>Note: If there are handrails, measure between the handrails.</p>	<p><input checked="" type="checkbox"/> Yes <input type="checkbox"/> No</p> <p>Measurement: + 36"</p>		<p>Photo #:</p>	<ul style="list-style-type: none"> • Alter ramp • •
<p>1.26 Is the surface stable, firm and slip resistant? [405.4]</p>	<p><input checked="" type="checkbox"/> Yes <input type="checkbox"/> No</p>		<p>Photo #:</p>	<ul style="list-style-type: none"> • Resurface ramp • •
<p>1.27 For each section of the ramp, is the running slope no greater than 1:12, i.e. for every inch of height change there are at least 12 inches of ramp run? [405.2]</p> <p>Note: Rises no greater than 3 inches with a slope no steeper than 1:8 and rises no greater than 6 inches with a slope no steeper than 1:10 are permitted when such slopes are necessary due to space limitations.</p>	<p><input checked="" type="checkbox"/> Yes <input type="checkbox"/> No</p> <p>Measurement: 1"</p>		<p>Photo #:</p>	<ul style="list-style-type: none"> • Relocate ramp • Lengthen ramp to decrease slope •

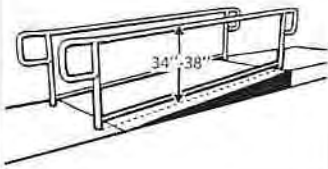
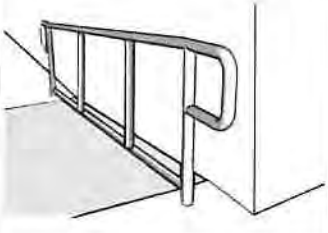
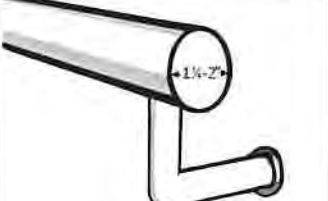
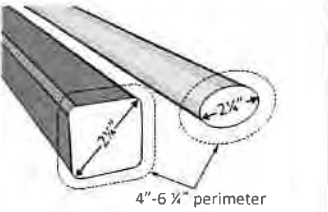

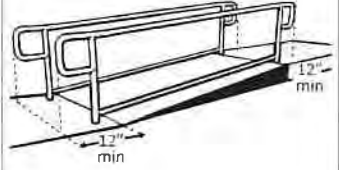
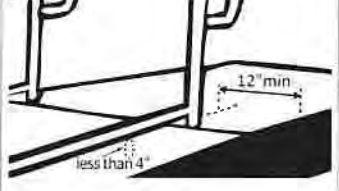
<p>1.28 Is there a level landing that is at least 60 inches long and at least as wide as the ramp:</p> <p>At the top of the ramp?</p> <p><input type="checkbox"/> Yes <input checked="" type="checkbox"/> No</p> <p>Measurement:</p> <p>At the bottom of the ramp?</p> <p>[405.7.2, 405.7.3]</p> <p><input type="checkbox"/> Yes <input type="checkbox"/> No</p> <p>Measurement:</p>	<p><input type="checkbox"/> Yes <input checked="" type="checkbox"/> No</p> <p>Measurement:</p> <p><input type="checkbox"/> Yes <input type="checkbox"/> No</p> <p>Measurement:</p>		<p>Photo #:</p>	<ul style="list-style-type: none"> • Alter ramp • Relocate ramp •
<p>1.29 Is there a level landing where the ramp changes direction that is at least 60 x 60 inches?</p> <p>[405.7.4]</p>	<p><input type="checkbox"/> Yes <input type="checkbox"/> No</p> <p>Measurement:</p> <p>N/A</p>		<p>Photo #:</p>	<ul style="list-style-type: none"> • Alter ramp • Increase landing size •
<p>1.30 If the ramp has a rise higher than 6 inches, are there handrails on both sides?</p> <p>[405.8]</p> <p>Note: Curb ramps are not required to have handrails.</p>	<p><input type="checkbox"/> Yes <input type="checkbox"/> No</p> <p>Measurement:</p> <p>N/A</p>		<p>Photo #:</p>	<ul style="list-style-type: none"> • Add handrails • •

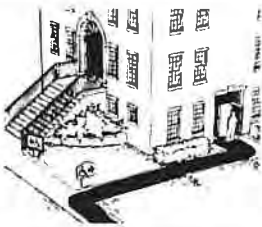
<p>1.31 Is the top of the handrail gripping surface no less than 34 inches and no greater than 38 inches above the ramp surface? [505.4]</p> <p style="text-align: center;"><i>NA</i></p>	<p><input type="checkbox"/> Yes <input type="checkbox"/> No</p> <p>Measurement:</p> <p style="text-align: center;"><i>NA</i></p>		<p>Photo #:</p>	<ul style="list-style-type: none"> • Reconfigure or replace handrails • Adjust handrail height •
<p>1.32 Is the handrail gripping surface continuous and not obstructed along the top or sides? [505.3]</p> <p>If there are obstructions, is the bottom of the gripping surface obstructed no greater than 20%? [505.6]</p> <p style="text-align: center;"><i>NA</i></p>	<p><input type="checkbox"/> Yes <input type="checkbox"/> No</p> <p style="text-align: center;"><i>NA</i></p> <p><input type="checkbox"/> Yes <input type="checkbox"/> No</p> <p>Measurement:</p> <p style="text-align: center;"><i>NA</i></p>		<p>Photo #:</p>	<ul style="list-style-type: none"> • Reconfigure or replace handrails • •
<p>1.33 If the handrail gripping surface is circular, is it no less than 1 1/4 inches and no greater than 2 inches in diameter? [505.7.1]</p> <p style="text-align: center;"><i>NA</i></p>	<p><input type="checkbox"/> Yes <input type="checkbox"/> No</p> <p>Measurement:</p> <p style="text-align: center;"><i>NA</i></p>		<p>Photo #:</p>	<ul style="list-style-type: none"> • Replace handrails • •
<p>1.34 If the handrail gripping surface is non-circular:</p> <p style="text-align: center;"><i>NA</i></p> <p>Is the perimeter no less than 4 inches and no greater than 6 1/2 inches?</p>	<p><input type="checkbox"/> Yes <input type="checkbox"/> No</p> <p>Measurement:</p> <p style="text-align: center;"><i>NA</i></p> <p><input type="checkbox"/> Yes <input type="checkbox"/> No</p> <p>Measurement:</p> <p style="text-align: center;"><i>NA</i></p>		<p>Photo #:</p>	<ul style="list-style-type: none"> • Replace handrails • •

<p>Is the cross section no greater than 2¼ inches? [505.7.2]</p>	<p><input type="checkbox"/> Yes <input type="checkbox"/> No Measurement: NA</p>		<p>Photo #:</p>	
<p>1.35 Does the handrail:</p> <p>Extend at least 12 inches horizontally beyond the top and bottom of the ramp? NA</p> <p>Return to a wall, guard, or landing surface? [505.10.1] NA</p> <p>Note: If a 12 inch extension would be a hazard (in circulation path) it is not required.</p>	<p><input type="checkbox"/> Yes <input type="checkbox"/> No Measurement: NA</p> <p><input type="checkbox"/> Yes <input type="checkbox"/> No NA</p>		<p>Photo #:</p>	<ul style="list-style-type: none"> • Alter handrails • •
<p>1.36 To prevent wheelchair casters and crutch tips from falling off:</p> <p>Does the surface of the ramp extend at least 12 inches beyond the inside face of the handrail? NA</p> <p>Or</p> <p>Is there a curb or barrier that prevents the passage of a 4-inch diameter sphere? [405.9.1, 405.9.2]</p>	<p><input type="checkbox"/> Yes <input type="checkbox"/> No Measurement: NA</p> <p><input type="checkbox"/> Yes <input type="checkbox"/> No Measurement: NA</p>		<p>Photo #:</p>	<ul style="list-style-type: none"> • Add curb • Add barrier • Extend ramp width •

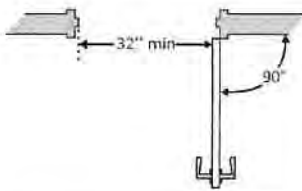
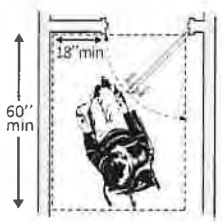
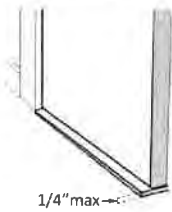
Entrance				
<p>1.37 Is the main entrance accessible?</p>	<p><input checked="" type="checkbox"/> Yes <input type="checkbox"/> No</p>		<p>Photo #:</p>	<ul style="list-style-type: none"> • Redesign to make it accessible • •
<p>1.38 If the main entrance is not accessible, is there an alternative accessible entrance? Can the alternative accessible entrance be used independently and during the same hours as the main entrance?</p>	<p><input checked="" type="checkbox"/> Yes <input type="checkbox"/> No <input checked="" type="checkbox"/> Yes <input type="checkbox"/> No</p>		<p>Photo #:</p>	<ul style="list-style-type: none"> • Designate an entrance and make it accessible • Ensure that accessible entrance can be used independently and during the same hours as the main entrance •
<p>1.39 Do all inaccessible entrances have signs indicating the location of the nearest accessible entrance? [216.6]</p>	<p><input type="checkbox"/> Yes <input checked="" type="checkbox"/> No</p>		<p>Photo #:</p>	<ul style="list-style-type: none"> • Install signs • Install signs on route before people get to inaccessible entrances so that people do not have to turn around and retrace route •
<p>1.40 If not all entrances are accessible, is there a sign at the accessible entrance with the International Symbol of Accessibility? [216.6]</p>	<p><input type="checkbox"/> Yes <input type="checkbox"/> No</p>		<p>Photo #:</p>	<ul style="list-style-type: none"> • Install sign • •

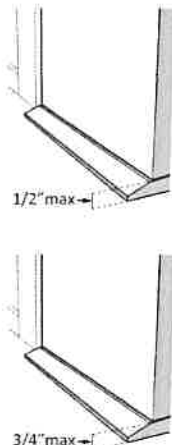
<p>1.41 Is the clear opening width of the accessible entrance door at least 32 inches, between the face of the door and the stop, when the door is open 90 degrees? [404.2.3]</p>	<p><input checked="" type="checkbox"/> Yes <input type="checkbox"/> No Measurement: 33"</p>		<p>Photo #:</p>	<ul style="list-style-type: none"> • Alter door • Install offset hinges
<p>1.42 If there is a front approach to the pull side of the door, is there at least 18 inches of maneuvering clearance beyond the latch side plus at least 60 inches clear depth? Note: See 2010 Standards 404.2.4 for maneuvering clearance requirements on the push side of the door and side approaches to the pull side of the door</p> <p>On both sides of the door, is the ground or floor surface of the maneuvering clearance level (no steeper than 1:48)? [404.2.4]</p>	<p><input type="checkbox"/> Yes <input type="checkbox"/> No Measurement: N/A</p> <p><input checked="" type="checkbox"/> Yes <input type="checkbox"/> No Measurement: N/A</p>		<p>Photo #:</p>	<ul style="list-style-type: none"> • Remove obstructions • Reconfigure walls • Add automatic door opener
<p>1.43 If the threshold is vertical is it no more than 1/4 inch high? Or No more than 1/2 inch high with the top 1/4 inch beveled no steeper than 1:2, if the threshold was installed on or</p>	<p><input type="checkbox"/> Yes <input type="checkbox"/> No Measurement: N/A</p> <p><input checked="" type="checkbox"/> Yes <input type="checkbox"/> No Measurement: 1/2" 1/4"</p>		<p>Photo #:</p>	<ul style="list-style-type: none"> • Remove or replace threshold

<p>after the 1991 ADA Standards went into effect (1/26/93)?</p> <p>Or</p> <p>No more than ¼ inch high with the top ¼ inch beveled no steeper than 1:2, if the threshold was installed before the 1991 ADA Standards went into effect (1/26/93)? [404.2.5, 303.2]</p> <p>Note: The first ¼ inch of the ½ or ¾ inch threshold may be vertical; the rest must be beveled.</p>	<p><input type="checkbox"/> Yes <input type="checkbox"/> No</p> <p>Measurement:</p> <p><i>N/A</i></p>		<p>Photo #:</p>	
<p>1.44 Is the door equipped with hardware that is operable with one hand and does not require tight grasping, pinching or twisting of the wrist?</p> <p>Door handle?</p> <p>Lock (if provided)? [404.2.7]</p>	<p><input checked="" type="checkbox"/> Yes <input type="checkbox"/> No</p> <p><input checked="" type="checkbox"/> Yes <input type="checkbox"/> No</p> <p><input checked="" type="checkbox"/> Yes <input type="checkbox"/> No</p>		<p>Photo #:</p>	<ul style="list-style-type: none"> • Replace inaccessible knob with lever, loop or push hardware • Add automatic door opener

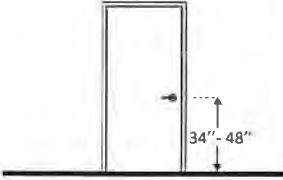
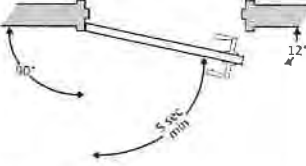
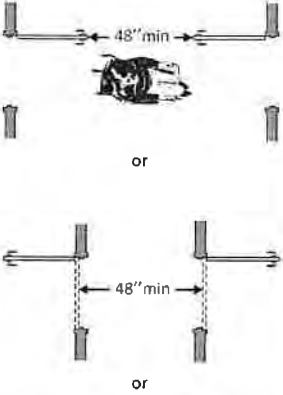
<p>1.45 Are the operable parts of the door hardware no less than 34 inches and no greater than 48 inches above the floor or ground surface? [404.2.7]</p>	<p><input checked="" type="checkbox"/> Yes <input type="checkbox"/> No Measurement: 36"</p>		<p>Photo #:</p>	<ul style="list-style-type: none"> • Change hardware height • •
<p>1.46 If the door has a closer, does it take at least 5 seconds to close from an open position of 90 degrees to a position of 12 degrees from the latch? [404.2.8]</p>	<p><input type="checkbox"/> Yes <input type="checkbox"/> No Measurement: 3 SEC.</p>		<p>Photo #:</p>	<ul style="list-style-type: none"> • Adjust closer • •
<p>1.47 If there are two doors in a series, e.g. vestibule, is the distance between the doors at least 48 inches plus the width of the doors when swinging into the space? [404.2.6]</p>	<p><input type="checkbox"/> Yes <input type="checkbox"/> No Measurement: NA</p>		<p>Photo #:</p>	<ul style="list-style-type: none"> • Remove inner door • Change door swing •

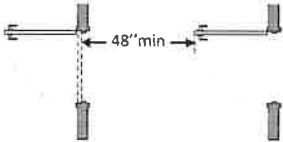
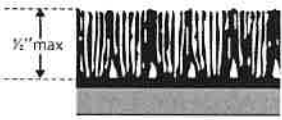
			Photo #:	
<p>1.48 If provided at the building entrance, are carpets or mats no higher than 1/2 inch thick? [302.2]</p>	<input type="checkbox"/> Yes <input type="checkbox"/> No Measurement: <i>NA</i>		Photo #:	<ul style="list-style-type: none"> • Replace or remove mats • •
<p>1.49 Are edges of carpets or mats securely attached to minimize tripping hazards? [302.2]</p>	<input type="checkbox"/> Yes <input type="checkbox"/> No <i>NA</i>		Photo #:	<ul style="list-style-type: none"> • Secure carpeting or mats at edges • •
	<input type="checkbox"/> Yes <input type="checkbox"/> No <i>NA</i>		Photo #:	<ul style="list-style-type: none"> • • •
	<input type="checkbox"/> Yes <input type="checkbox"/> No <i>NA</i>		Photo #:	<ul style="list-style-type: none"> • • •

ADA Checklist for Existing Facilities

Priority 2 – Access to Goods & Services

Based on the 2010 ADA Standards for Accessible Design

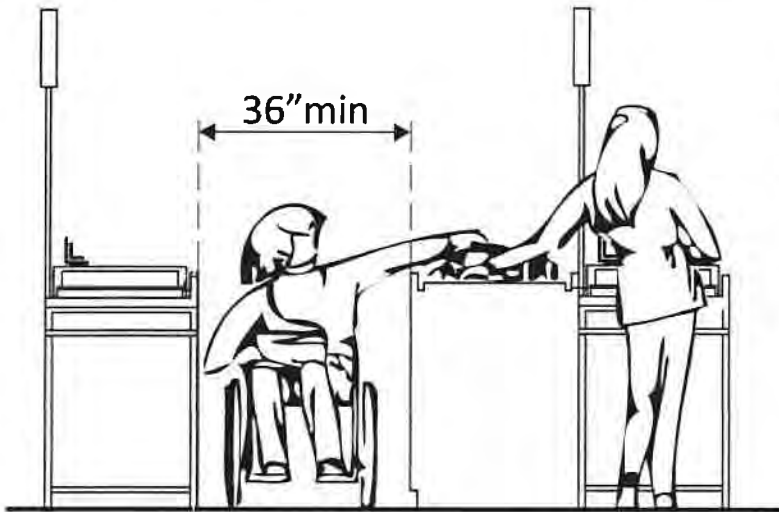

Project ADA TRANSITION PLAN

Building PUBLIC WORKS BUILDING

Location WEAVERVILLE NC

Date 4-20-2020

Surveyors ALAN F. WACKY

Contact Information DALE PENNELL

The layout of the building should allow people with disabilities to obtain goods and services and to participate in activities without assistance.



Institute for Human Centered Design
www.HumanCenteredDesign.org
Copyright © 2016



ADA National Network
Questions on the ADA 800-949-4232 voice/tty
www.ADAchecklist.org

This checklist was produced by the New England ADA Center, a project of the Institute for Human Centered Design and a member of the ADA National Network. This checklist was developed under a grant from the Department of Education, NIDRR grant number H133A060092-09A. However the contents do not necessarily represent the policy of the Department of Education, and you should not assume endorsement by the Federal Government.

Questions or comments on the checklist contact the New England ADA Center at 617-695-0085 voice/tty or ADAinfo@NewEnglandADA.org

For the full set of checklists, including the checklists for recreation facilities visit www.ADAchecklist.org.

Copyright © 2016 ADA Checklist for Existing Materials. You can freely reproduce and distribute this content. Include proper attribution. But you must get permission before using this content as a fee-based product.

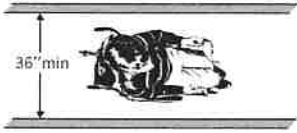
Priority 2 – Access to Goods & Services		Comments	Possible Solutions
<p>2.1 Does the accessible entrance provide direct access to the main floor, lobby and elevator? [See 2010 ADA Standards for Accessible Design – 206.4]</p>	<p><input checked="" type="checkbox"/> Yes <input type="checkbox"/> No</p>	<p>Photo #:</p>	<ul style="list-style-type: none"> • Create accessible route • •
<p>Interior Accessible Route</p>			
<p>2.2 Are all public spaces on at least one accessible route? [206.2.4]</p>	<p><input checked="" type="checkbox"/> Yes <input type="checkbox"/> No</p>	<p>Photo #:</p>	<ul style="list-style-type: none"> • Create accessible route • •
<p>2.3 Is the route stable, firm and slip-resistant? [40.2, 302.1]</p>	<p><input checked="" type="checkbox"/> Yes <input type="checkbox"/> No</p>	<p>Photo #:</p>	<ul style="list-style-type: none"> • Repair uneven surfaces • •
<p>2.4 Is the route at least 36 inches wide? [403.5.1]</p> <p>Note: The accessible route can narrow to 32 inches min. for a max. of 24 inches. These narrower portions of the route must be at least 48 inches from each other.</p>	<p>Measurement:</p> <p>+36"</p>		<ul style="list-style-type: none"> • Widen route • •

			<p>Photo #:</p>	
<p>2.5 If the route is greater than 200 feet in length and less than 60 inches wide, is there a passing space no less than 60 x 60 inches? [403.5.3]</p>	<p><input type="checkbox"/> Yes <input type="checkbox"/> No Measurement: NA</p>		<p>Photo #:</p>	<ul style="list-style-type: none"> • Widen route for passing space • •
<p>2.6 Is the running slope no steeper than 1:20, i.e. for every inch of height change there are at least 20 inches of route run? [403.3]</p> <p>Note: If the running slope is steeper than 1:20, treat as a ramp and add features such as edge protection and handrails.</p>	<p><input type="checkbox"/> Yes <input type="checkbox"/> No Measurement: NA</p>		<p>Photo #:</p>	<ul style="list-style-type: none"> • Regrade • •
<p>2.7 Is the cross slope no steeper than 1:48? [403.3]</p>	<p><input type="checkbox"/> Yes <input type="checkbox"/> No Measurement: NA</p>		<p>Photo #:</p>	<ul style="list-style-type: none"> • Regrade • •

2.8 Do all objects on circulation paths through public areas, e.g. fire extinguishers, drinking fountains, signs, etc., protrude no more than 4 inches into the path?

Yes No

Measurement:

N/A



Or

Or

If an object protrudes more than 4 inches, is the bottom leading edge at 27 inches or lower above the floor? [307.2]

Yes No

Measurement:

N/A

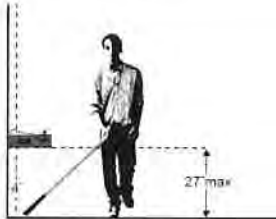

Or

Or

Is the bottom leading edge at 80 inches or higher above the floor? [307.4]

Yes No

Measurement:

N/A



Photo #:

- Remove object
- Add tactile warning such as permanent planter or partial walls
-

2.9 Are there elevators or platform lifts to all public stories?

Yes No

Note: Vertical access is not required in new construction or alterations if a facility is less than three stories or has less than 3,000 square feet per story, unless the facility is a shopping center, shopping mall,

N/A

- Install if necessary
- Offer goods and services on an accessible story
-

professional office of a health care provider, transportation terminal, state facility or local government facility

Photo #:

Ramps

2.10 If there is a ramp, is it at least 36 inches wide? [405.5]

Yes No

Measurement:

+ 36"

Note: If there are handrails, measure between the handrails.

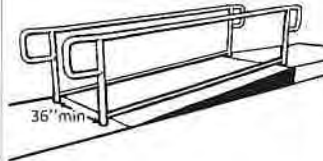

Photo #:

- Alter ramp
-
-

2.11 Is the surface stable, firm and slip resistant? [405.4]

Yes No

Photo #:

- Resurface ramp
-
-

2.12 For each section of the ramp, is the running slope no greater than 1:12, i.e. for every inch of height change there are at least 12 inches of ramp run? [405.2]

Yes No

Measurement:

1"

Note: Rises no greater than 3 inches with a slope no steeper than 1:8 and rises no greater

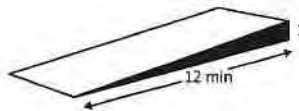
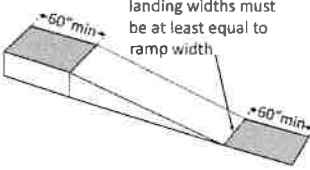
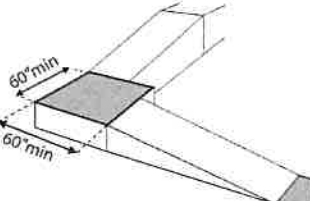
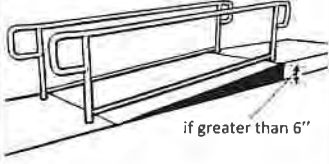
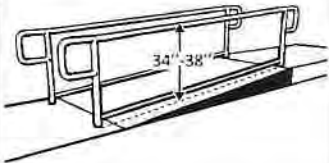
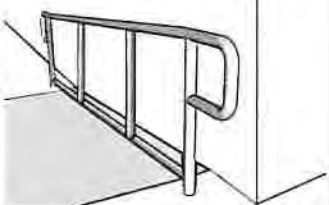
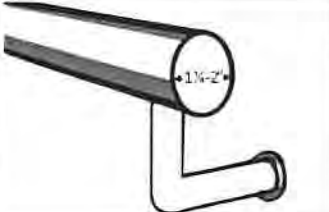
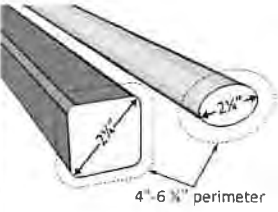
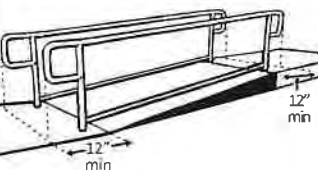
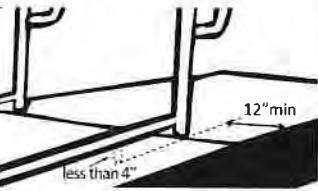

Photo #:

- Lengthen ramp to decrease slope
- Relocate ramp
-

<p>than 6 inches with a slope no steeper than 1:10 are permitted when due to space limitations.</p>			<p>Photo #:</p>	
<p>2.13 Is there a level landing that is at least 60 inches long and at least as wide as the ramp:</p> <p>At the top of the ramp?</p> <p>At the bottom of the ramp? [405.7.2, 405.7.3]</p>	<p><input type="checkbox"/> Yes <input checked="" type="checkbox"/> No</p> <p>Measurement:</p> <p><input checked="" type="checkbox"/> Yes <input type="checkbox"/> No</p> <p>Measurement: + 60"</p>	 <p>landing widths must be at least equal to ramp width</p>	<p>Photo #:</p>	<ul style="list-style-type: none"> • Alter ramp • Relocate ramp •
<p>2.14 Is there a level landing where the ramp changes direction that is at least 60 x 60 inches? [405.7.4]</p>	<p><input type="checkbox"/> Yes <input type="checkbox"/> No</p> <p>Measurement: N/A</p>		<p>Photo #:</p>	<ul style="list-style-type: none"> • Increase landing size • •

<p>2.15 If the ramp has a rise higher than 6 inches are there handrails on both sides? [405.8]</p>	<p><input type="checkbox"/> Yes <input type="checkbox"/> No Measurement: NA</p>		<p>Photo #:</p> <ul style="list-style-type: none"> • Add handrails • •
<p>2.16 Is the top of the handrail gripping surface no less than 34 inches and no greater than 38 inches above the ramp surface? [505.4]</p>	<p><input type="checkbox"/> Yes <input type="checkbox"/> No Measurement: NA</p>		<p>Photo #:</p> <ul style="list-style-type: none"> • Adjust handrail height • •
<p>2.17 Is the handrail gripping surface continuous and not obstructed along the top or sides? [505.3]</p> <p>If there are obstructions, is the bottom of the gripping surface obstructed no more than 20%? [505.6]</p>	<p><input type="checkbox"/> Yes <input type="checkbox"/> No NA <input type="checkbox"/> Yes <input type="checkbox"/> No Measurement: NA</p>		<p>Photo #:</p> <ul style="list-style-type: none"> • Reconfigure or replace handrails • •
<p>2.18 If the handrail gripping surface is circular, is it no less than 1 1/4 inches and no greater than 2 inches in diameter? [505.7.1]</p>	<p><input type="checkbox"/> Yes <input type="checkbox"/> No Measurement: NA</p>		<p>Photo #:</p> <ul style="list-style-type: none"> • Replace handrails • •



<p>2.19 If the handrail gripping surface is non-circular:</p> <p>Is the perimeter no less than 4 inches and no greater than 6 1/4 inches?</p> <p>Is the cross section no greater than 2 1/4 inches in diameter? [505.7.2]</p>	<p><input type="checkbox"/> Yes <input type="checkbox"/> No</p> <p>Measurement: N/A</p> <p><input type="checkbox"/> Yes <input type="checkbox"/> No</p> <p>Measurement: N/A</p>		<p>Photo #:</p> <ul style="list-style-type: none"> • Replace handrails • •
<p>2.20 Does the handrail:</p> <p>Extend at least 12 inches horizontally beyond the top and bottom of the ramp?</p> <p>Return to a wall, guard, or landing surface? [505.10.1]</p> <p>Note: If a 12" extension would be hazardous (in circulation path), it is not required</p>	<p><input type="checkbox"/> Yes <input type="checkbox"/> No</p> <p>Measurement: N/A</p> <p><input type="checkbox"/> Yes <input type="checkbox"/> No</p> <p>Measurement: N/A</p>		<p>Photo #:</p> <ul style="list-style-type: none"> • Alter handrails • •
<p>2.21 To prevent wheelchair casters and crutch tips from falling off:</p> <p>Does the surface of the ramp extend at least 12 inches beyond the inside face of the handrail?</p> <p>Or</p>	<p><input type="checkbox"/> Yes <input type="checkbox"/> No</p> <p>Measurement: N/A</p> <p><input type="checkbox"/> Yes <input type="checkbox"/> No</p> <p>Measurement: N/A</p>		<p>Photo #:</p> <ul style="list-style-type: none"> • Add curb • Add barrier • Extend ramp width • •

<p>Is there a curb or barrier that prevents the passage of a 4-inch diameter sphere? [405.9.1, 405.9.2]</p>	<p>Measurement: N/A</p>	<p>Photo #:</p>
-----------------------------------------------------------------------------------------------------------------	-----------------------------	-----------------

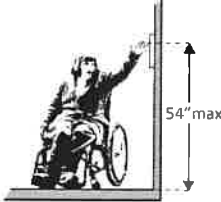

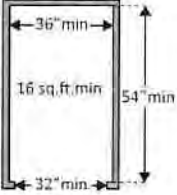
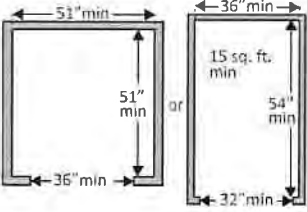
Elevators – Full Size & LULA (limited use, limited application) LULA elevators are often used in alterations.

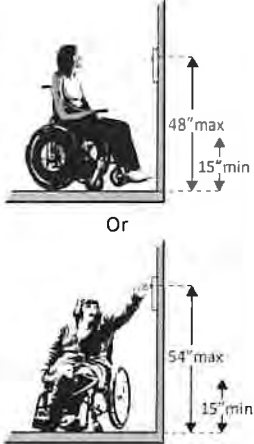

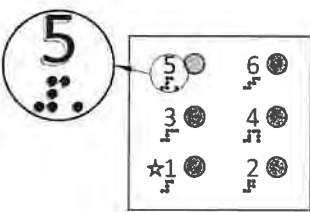
<p>2.22 If there is a full size or LULA elevator, are the call buttons no higher than 54 inches above the floor? [407.2.1.1]</p>	<p><input type="checkbox"/> Yes <input type="checkbox"/> No Measurement: N/A</p>		<ul style="list-style-type: none"> • Change call button height • •
<p>2.23 If there is a full size or LULA elevator, does the sliding door reopen automatically when obstructed by an object or person?*</p>	<p><input type="checkbox"/> Yes <input type="checkbox"/> No N/A</p>	<p>Photo #:</p>	<p>* If constructed before 3/15/2012 and manually operated, the door is not required to reopen automatically</p> <ul style="list-style-type: none"> • Install opener •

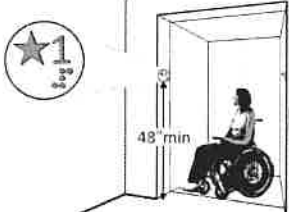
<p>2.24 If there is a LULA elevator with a swinging door:</p> <p>Is the door power-operated? <input type="checkbox"/> Yes <input type="checkbox"/> No</p> <p>Does the door remain open for at least 20 seconds when activated? [403.3.2]</p>	<p>NA</p> <p><input type="checkbox"/> Yes <input type="checkbox"/> No</p> <p><input type="checkbox"/> Yes <input type="checkbox"/> No</p> <p>Time:</p>		<p>Photo #:</p>	<ul style="list-style-type: none"> • Add power operated door • Adjust opening time
<p>2.25 If there is a full size elevator:</p> <p>Is the interior at least 54 inches deep by at least 36 inches wide with at least 16 sq. ft. of clear floor area?</p> <p>Is the door opening width at least 32 inches? [407.4.1 Exception]</p>	<p><input type="checkbox"/> Yes <input type="checkbox"/> No</p> <p>Measurement:</p> <p>NA</p> <p><input type="checkbox"/> Yes <input type="checkbox"/> No</p> <p>Measurement:</p> <p>NA</p>		<p>Photo #:</p>	<ul style="list-style-type: none"> • Replace elevator
<p>2.26 If there is a LULA elevator, is the interior:</p> <p>At least 51 inches deep by 51 inches wide with a door opening width of at least 36 inches?</p> <p>Or</p> <p>At least 54 inches deep by at least 36 inches wide with at least 15 sq. ft. of clear floor area and a door opening width of at least 32 inches? [408.4.1 Exceptions 1 and 2]</p>	<p><input type="checkbox"/> Yes <input type="checkbox"/> No</p> <p>Measurement:</p> <p>NA</p> <p><input type="checkbox"/> Yes <input type="checkbox"/> No</p> <p>Measurement:</p> <p>NA</p>		<p>Photo #:</p>	<ul style="list-style-type: none"> • Replace elevator

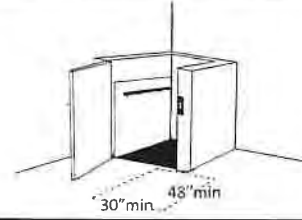
<p>2.27 If there is a full size or LULA elevator, are the in-car controls:</p> <p>No less than 15 inches and no greater 48 inches above the floor?</p> <p>Or</p> <p>Up to 54 inches above the floor for a parallel approach? [408.4.6, 407.4.6.1]</p>	<p><input type="checkbox"/> Yes <input type="checkbox"/> No</p> <p>Measurement: NA</p> <p><input type="checkbox"/> Yes <input type="checkbox"/> No</p> <p>Measurement: NA</p>	 <p>Or</p>	<p>Photo #:</p>	<ul style="list-style-type: none"> • Change control height • •
<p>2.28 If there is a LULA elevator, are the in-car controls centered on a side wall? [408.4.6]</p>	<p><input type="checkbox"/> Yes <input type="checkbox"/> No</p> <p>Measurement: NA</p>		<p>Photo #:</p>	<ul style="list-style-type: none"> • Reconfigure controls • •
<p>2.29 If there is a full size or LULA elevator:</p> <p>Are the car control buttons designated with raised characters?</p> <p>Are the car control buttons designated with Braille?</p>	<p><input type="checkbox"/> Yes <input type="checkbox"/> No</p> <p>NA</p> <p><input type="checkbox"/> Yes <input type="checkbox"/> No</p> <p>NA</p>		<p>Photo #:</p>	<ul style="list-style-type: none"> • Add raised characters • Add Braille •

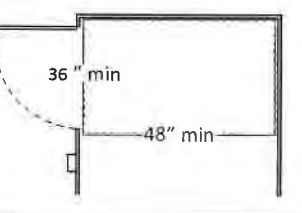
[407.4.7.1, 703.2]			Photo #:	
<p>2.30 If there is a full size or LULA elevator, are there audible signals which sound as the car passes or is about to stop at a floor? [407.4.8]</p>	<p><input type="checkbox"/> Yes <input type="checkbox"/> No</p> <p>N/A</p>		Photo #:	<ul style="list-style-type: none"> • Install audible signals • •
<p>2.31 If there is a full size or LULA elevator:</p> <p>Is there a sign on both door jambs at every floor identifying the floor?</p> <p>Is there a tactile star on both jambs at the main entry level?</p> <p>Do text characters contrast with their backgrounds?</p> <p>Are text characters raised?</p> <p>Is there Braille?</p> <p>Is the sign mounted between 48 inches to the baseline of the lowest character and 60 inches to the baseline of the highest character above the floor?*</p> <p>[407.2.3, 408.2.3]</p>	<p><input type="checkbox"/> Yes <input type="checkbox"/> No</p> <p>N/A</p> <p><input type="checkbox"/> Yes <input type="checkbox"/> No</p> <p>N/A</p> <p><input type="checkbox"/> Yes <input type="checkbox"/> No</p> <p>N/A</p> <p><input type="checkbox"/> Yes <input type="checkbox"/> No</p> <p>N/A</p> <p><input type="checkbox"/> Yes <input type="checkbox"/> No</p> <p>N/A</p> <p><input type="checkbox"/> Yes <input type="checkbox"/> No</p> <p>N/A</p> <p>Measurement:</p>		Photo #:	<ul style="list-style-type: none"> • Install signs • Change sign height • • <p>* If constructed before 3/15/2012 and mounted no higher than 60 inches to the centerline of the sign, relocation is not required</p>
Platform Lifts				

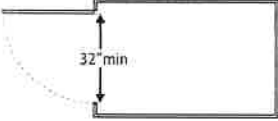
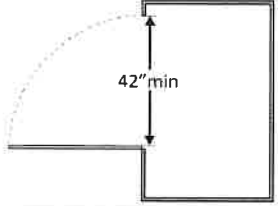
<p>2.32 If a lift is provided, can it be used without assistance from others? [410.1]</p>	<p><input type="checkbox"/> Yes <input type="checkbox"/> No</p>		<ul style="list-style-type: none"> • Reconfigure so independently operable • •
<p>2.33 Is there a clear floor space at least 30 inches wide by at least 48 inches long for a person using a wheelchair to approach and reach the controls to use the lift? [410.5]</p>	<p><input type="checkbox"/> Yes <input type="checkbox"/> No</p>	<p>Measurement:</p> 	<ul style="list-style-type: none"> • Remove obstructions • •
<p>2.34 Are the lift controls no less than 15 inches and no greater than 48 inches above the floor? [410.5]</p>	<p><input type="checkbox"/> Yes <input type="checkbox"/> No</p>	<p>Measurement:</p> 	<ul style="list-style-type: none"> • Change control height • •
<p>2.35 Is there a clear floor space at least 36 inches wide by at least 48 inches long inside the lift? [410.3]</p>	<p><input type="checkbox"/> Yes <input type="checkbox"/> No</p>	<p>Measurement:</p> 	<ul style="list-style-type: none"> • Replace lift • •

<p>2.36 If there is an end door, is the clear opening width at least 32 inches? [410.6]</p>	<p><input type="checkbox"/> Yes <input type="checkbox"/> No</p> <p>Measurement:</p> <p>N/A</p>		<p>Photo #:</p>	<ul style="list-style-type: none"> • Alter door width • •
<p>2.37 If there is a side door, is the clear opening width at least 42 inches? [410.6]</p>	<p><input type="checkbox"/> Yes <input type="checkbox"/> No</p> <p>Measurement:</p> <p>N/A</p>		<p>Photo #:</p>	<ul style="list-style-type: none"> • Alter door width • •
<p>Signs "Tactile characters" are read using touch, i.e. raised characters and Braille.</p>				
<p>2.38 If there are signs designating permanent rooms and spaces not likely to change over time, e.g. room numbers and letters, room names, and exit signs: [216.2]</p> <p>Do text characters contrast with their backgrounds? [703.5]</p> <p>Are text characters raised? [703.2]</p> <p>Is there Braille? [703.3]</p> <p>Is the sign mounted:</p>	<p><input type="checkbox"/> Yes <input type="checkbox"/> No</p> <p>N/A</p> <p><input type="checkbox"/> Yes <input type="checkbox"/> No</p> <p>N/A</p> <p><input type="checkbox"/> Yes <input type="checkbox"/> No</p> <p>N/A</p>		<p>Photo #:</p>	<ul style="list-style-type: none"> • Install tactile sign • Relocate sign •

On the wall on the latch side of the door?
[703.4.2]

Yes No

N/A

Note: Signs are permitted on the push side of doors with closers and without hold-open devices.

With clear floor space beyond the arc of the door swing and 45-degree open position, at least 18 x 18 inches centered on the tactile characters?*

Yes No

Measurement:

N/A

So the baseline of the lowest character is at least 48 inches above the floor and the baseline of the highest character is no more than 60 inches above the floor? *

Yes No

Measurement:

N/A

Note: If the sign is at double doors with one active leaf, the sign should be on the inactive leaf; if both leaves are active, the sign should be on the wall to the right of the right leaf.

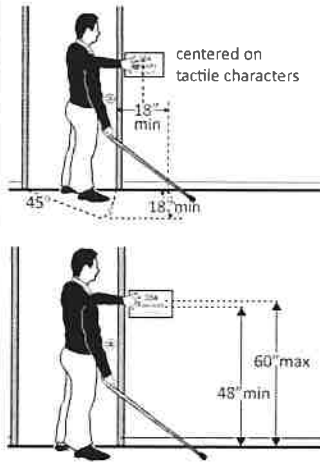
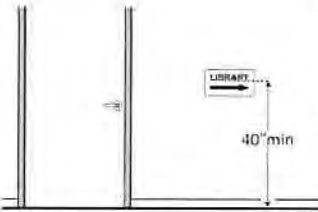
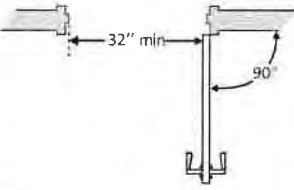
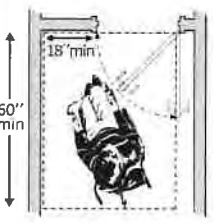
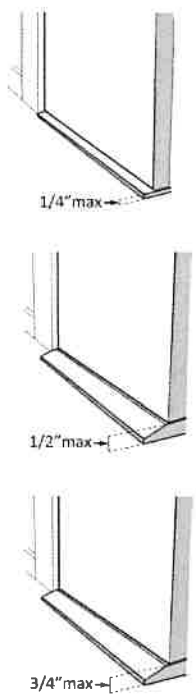



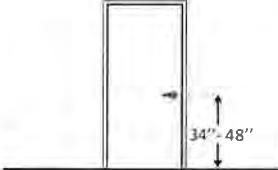

Photo #:

*If constructed before 3/15/2012 and a person may approach within 3 inches of the sign without encountering protruding objects or standing within the door swing, relocation not required

*If constructed before 3/15/2012 and mounted no higher than 60 inches to the centerline of the sign, relocation not required

<p>2.39 If there are signs that provide direction to or information about interior spaces: Do text characters contrast with their backgrounds? [703.5.1] Is the sign mounted so that characters are at least 40 inches above the floor? [703.5.6] Note: Raised characters and Braille are not required.</p>	<p><input type="checkbox"/> Yes <input type="checkbox"/> No <i>N/A</i></p> <p><input type="checkbox"/> Yes <input type="checkbox"/> No Measurement: <i>N/A</i></p>		<p>Photo #:</p> <ul style="list-style-type: none"> • Install signs with contrasting characters • Change sign height
<p>Interior Doors – to classrooms, medical exam rooms, conference rooms, etc.</p>			
<p>2.40 Is the door opening width at least 32 inches clear, between the face of the door and the stop, when the door is open 90 degrees? [404.2.3]</p>	<p><input checked="" type="checkbox"/> Yes <input type="checkbox"/> No Measurement: <i>36"</i></p>		<p>Photo #:</p> <ul style="list-style-type: none"> • Install offset hinges • Alter the doorway
<p>2.41 If there is a front approach to the pull side of the door, is there at least 18 inches of maneuvering clearance beyond the latch side plus at least 60 inches clear depth? Note: See 2010 Standards 404.2.4 for maneuvering clearance requirements on the push side of the door and side approaches to the pull side of the door.</p>	<p><input type="checkbox"/> Yes <input type="checkbox"/> No Measurement: <i>N/A</i></p>		<ul style="list-style-type: none"> • Remove obstructions • Reconfigure walls • Add automatic door opener

<p>On both sides of the door, is the floor surface of the maneuvering clearance level (no steeper than 1:48)? [404.2.4]</p>	<p><input checked="" type="checkbox"/> Yes <input type="checkbox"/> No Measurement: LEVEL</p>		<p>Photo #:</p>	
<p>2.42 If the threshold is vertical is it no more than 1/4 inch high? Or No more than 1/2 inch high with the top 1/4 inch beveled no steeper than 1:2, if the threshold was installed on or after the 1991 ADA Standards went into effect (1/26/93)? Or No more than 3/4 inch high with the top 1/4 inch beveled no steeper than 1:2, if the threshold was installed before the 1991 ADA Standards went into effect (1/26/93)? [404.2.5, 303.2] Note: The first 1/4 inch of the 1/2 or 3/4 inch threshold may be vertical; the rest must be beveled.</p>	<p><input type="checkbox"/> Yes <input type="checkbox"/> No Measurement: N/A <input type="checkbox"/> Yes <input type="checkbox"/> No Measurement: N/A <input type="checkbox"/> Yes <input type="checkbox"/> No Measurement: N/A</p>		<p>Photo #:</p>	<ul style="list-style-type: none"> • Remove or replace threshold • •

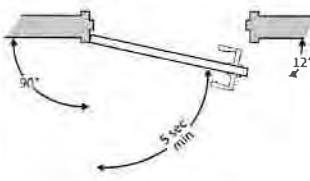
<p>2.43 Is the door equipped with hardware that is operable with one hand and does not require tight grasping, pinching or twisting of the wrist?</p> <p>Door handle?</p> <p>Lock (if provided)? [404.2.7]</p>	<p><input checked="" type="checkbox"/> Yes <input type="checkbox"/> No</p> <p><input checked="" type="checkbox"/> Yes <input type="checkbox"/> No</p> <p><input type="checkbox"/> Yes <input type="checkbox"/> No</p> <p><i>NA</i></p>		<p>Photo #:</p>	<ul style="list-style-type: none"> • Replace inaccessible knob with lever, loop or push hardware • Add automatic door opener
<p>2.44 Are the operable parts of the hardware no less than 34 inches and no greater than 48 inches above the floor?</p> <p>[404.2.7]</p>	<p><input checked="" type="checkbox"/> Yes <input type="checkbox"/> No</p> <p>Measurement:</p> <p><i>36"</i></p>		<p>Photo #:</p>	<ul style="list-style-type: none"> • Change hardware height
<p>2.45 Can the door be opened easily (5 pounds maximum force)?</p> <p>[404.2.9]</p> <p>Note: You can use a pressure gauge or fish scale to measure force. If you do not have one you will need to judge whether the door is easy to open.</p>	<p><input checked="" type="checkbox"/> Yes <input type="checkbox"/> No</p> <p>Measurement:</p> <p><i>3 lbs</i></p>		<p>Photo #:</p>	<ul style="list-style-type: none"> • Adjust or replace closers • Install lighter doors • Install power-assisted or automatic door openers
<p>2.46 If the door has a closer, does it take at least 5 seconds to close from an open position of 90 degrees to a position of 12 degrees from the latch?</p> <p>[404.2.8.1]</p>	<p><input type="checkbox"/> Yes <input type="checkbox"/> No</p> <p>Measurement:</p> <p><i>NA</i></p>		<p>Photo #:</p>	<ul style="list-style-type: none"> • Adjust closer

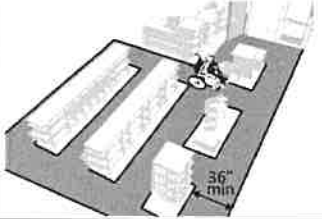
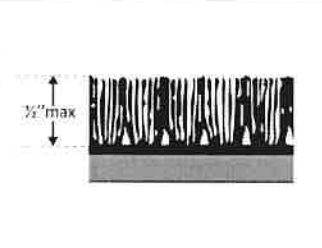
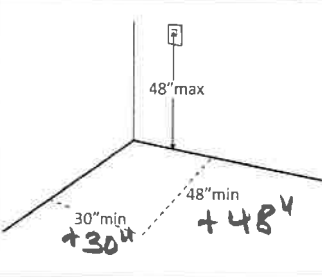
Rooms and Spaces – stores, supermarkets, libraries, etc.				
<p>2.47 Are aisles and pathways to goods and services, and to one of each type of sales and service counters, at least 36 inches wide? [403.5.1]</p>	<p><input type="checkbox"/> Yes <input type="checkbox"/> No Measurement: NA</p>		<p>Photo #:</p>	<ul style="list-style-type: none"> • Rearrange goods, equipment and furniture • •
<p>2.48 Are floor surfaces stable, firm and slip resistant? [302.1]</p>	<p><input checked="" type="checkbox"/> Yes <input type="checkbox"/> No</p>		<p>Photo #:</p>	<ul style="list-style-type: none"> • Change floor surface • •
<p>2.49 If there is carpet: Is it no higher than 1/2 inch? Is it securely attached along the edges? [302.2]</p>	<p><input type="checkbox"/> Yes <input type="checkbox"/> No Measurement: NA <input type="checkbox"/> Yes <input type="checkbox"/> No Measurement: NA</p>		<p>Photo #:</p>	<ul style="list-style-type: none"> • Replace carpet • •
Controls – light switches, security and intercom systems, emergency/alarm boxes, etc.				
<p>2.50 Is there a clear floor space at least 30 inches wide by at least 48 inches long for a forward or parallel approach? [305.3] Are the operable parts no higher than 48 inches above the floor?*[309.3, 308]</p>	<p><input checked="" type="checkbox"/> Yes <input type="checkbox"/> No Measurement: 48" <input type="checkbox"/> Yes <input type="checkbox"/> No Measurement: +30" + 48"</p>		<p>Photo #:</p>	<ul style="list-style-type: none"> • Change height of control • • <p>*If constructed before 3/15/2012 and a parallel approach is provided, controls can be 54 inches above the floor</p>

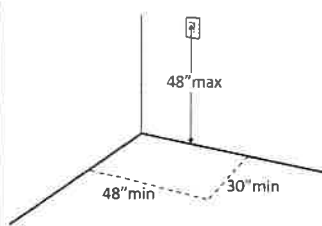

Photo #:

2.51 Can the control be operated with one hand and without tight grasping, pinching, or twisting of the wrist? [309.4]

Yes No

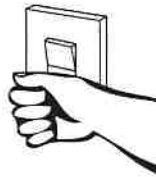

Photo #:

- Replace control
-
-

Seating: Assembly Areas – theaters, auditoriums, stadiums, theater style classrooms, etc.

2.52 Are an adequate number of wheelchair spaces provided? [221.2.1]

Yes No

Total #: *N/A*
Wheelchair #: *N/A*

# of Seats	Wheelchair Spaces
4 - 25	1
26 - 50	2
51 - 150	4
151 - 300	5
300+ see 2010 Standards 221.2.1.	

Photo #:

- Reconfigure to add wheelchair spaces
-
-

2.53 Are wheelchair spaces dispersed to allow location choices and viewing angles equivalent to other seating, including specialty seating areas that provide distinct services and amenities? [221.2.3]

Yes No

N/A

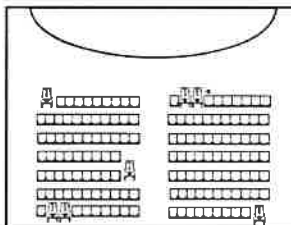

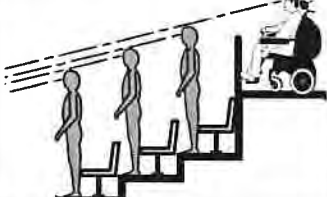

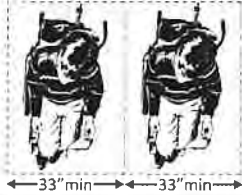
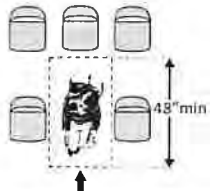
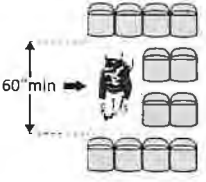
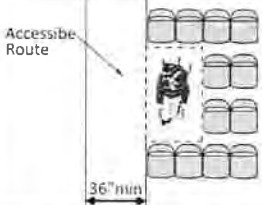
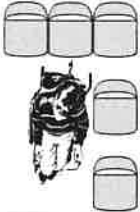



Photo #:

- Reconfigure to disperse wheelchair spaces
-
-

			Photo #:	
<p>2.54 Where people are expected to remain seated, do people in wheelchair spaces have a clear line of sight over and between the heads of others in front of them? [802.2.1.1, 802.1.1.2]</p>	<p><input type="checkbox"/> Yes <input type="checkbox"/> No N/A</p>		Photo #:	<ul style="list-style-type: none"> • Alter for line of sight • •
<p>2.55 Where people are expected to stand, do people in wheelchair spaces have a clear line of sight over and between the heads of others in front of them? [802.2.2.1, 802.1.2.2]</p>	<p><input type="checkbox"/> Yes <input type="checkbox"/> No N/A</p>		Photo #:	<ul style="list-style-type: none"> • Alter for line of sight • •
<p>2.56 If there is a single wheelchair space, is it at least 36 inches wide? [802.1.2]</p>	<p><input type="checkbox"/> Yes <input type="checkbox"/> No Measurement: N/A</p>		Photo #:	<ul style="list-style-type: none"> • Alter space • •

<p>2.57 If there are two adjacent wheelchair spaces, are they each at least 33 inches wide? [802.1.2]</p>	<p><input type="checkbox"/> Yes <input type="checkbox"/> No</p> <p>Measurement: N/A</p>		<p>Photo #:</p>	<ul style="list-style-type: none"> • Alter spaces • •
<p>2.58 If the wheelchair space can be entered from the front or rear, is it at least 48 inches deep? [802.1.3]</p>	<p><input type="checkbox"/> Yes <input type="checkbox"/> No</p> <p>Measurement: N/A</p>		<p>Photo #:</p>	<ul style="list-style-type: none"> • Alter space • •
<p>2.59 If the wheelchair space can only be entered from the side, is it at least 60 inches deep? [802.1.3]</p>	<p><input type="checkbox"/> Yes <input type="checkbox"/> No</p> <p>Measurement: N/A</p>		<p>Photo #:</p>	<ul style="list-style-type: none"> • Alter space • • •
<p>2.60 Do wheelchair spaces adjoin, but not overlap, accessible routes? [802.1.4]</p>	<p><input type="checkbox"/> Yes <input type="checkbox"/> No</p> <p>Measurement: N/A</p>		<p>Photo #:</p>	<ul style="list-style-type: none"> • Alter spaces • • •

<p>2.61 Is there at least one companion seat for each wheelchair space? [221.3]</p>	<p><input type="checkbox"/> Yes <input type="checkbox"/> No NA</p>		<p>Photo #:</p>	<ul style="list-style-type: none"> • Add companion seats • •
<p>2.62 Is the companion seat located so the companion is shoulder-to-shoulder with the person in a wheelchair? [802.3.1]</p>	<p><input type="checkbox"/> Yes <input type="checkbox"/> No NA</p>		<p>Photo #:</p>	<ul style="list-style-type: none"> • Alter seating • •
<p>2.63 Is the companion seat equivalent in size, quality, comfort and amenities to seating in the immediate area? [802.3.2]</p>	<p><input type="checkbox"/> Yes <input type="checkbox"/> No NA</p>		<p>Photo #:</p>	<ul style="list-style-type: none"> • Add equivalent seating • •
<p>Seating: At dining surfaces (restaurants, cafeterias, bars, etc.) and non-employee work surfaces (libraries, conference rooms, etc.)</p>				
<p>2.64 Are at least 5%, but no fewer than one, of seating and standing spaces accessible for people who use wheelchairs? [226.1]</p>	<p><input type="checkbox"/> Yes <input type="checkbox"/> No Total #: NA Wheelchair #: NA</p>		<p>Photo #:</p>	<ul style="list-style-type: none"> • Alter to provide accessible spaces • •
<p>2.65 Is there a route at least 36 inches wide to accessible seating? [403.5.1]</p>	<p><input type="checkbox"/> Yes <input type="checkbox"/> No Measurement: NA</p>		<p>Photo #:</p>	<ul style="list-style-type: none"> • Widen route • •

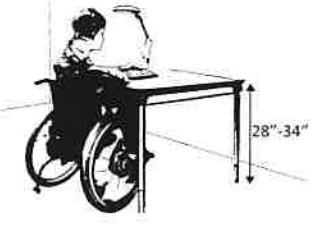
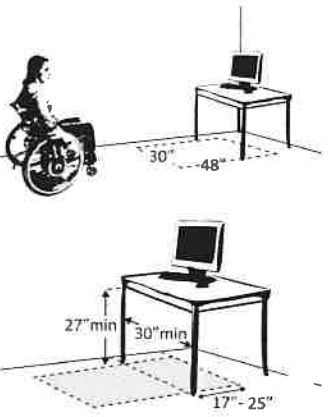
<p>2.66 At the accessible space(s), is the top of the accessible surface no less than 28 inches and no greater than 34 inches above the floor? [902.3]</p> <p>Note: If for children, the top should be no less than 26 inches and no greater than 30 inches above the floor.</p>	<p><input type="checkbox"/> Yes <input type="checkbox"/> No</p> <p>Measurement:</p> <p>N/A</p>		<p>Photo #:</p>	<ul style="list-style-type: none"> • Alter surface height • •
<p>2.67 Is there a clear floor space at least 30 inches wide by at least 48 inches long for a forward approach? [305.3]</p> <p>Does it extend no less than 17 inches and no greater than 25 inches under the surface?</p> <p>Is there knee space at least 27 inches high and at least 30 inches wide? [306.2, 306.3]</p> <p>Note: If for children, the knee space may be 24 inches high.</p>	<p><input type="checkbox"/> Yes <input type="checkbox"/> No</p> <p>Measurement:</p> <p>N/A</p> <p><input type="checkbox"/> Yes <input type="checkbox"/> No</p> <p>Measurement:</p> <p>N/A</p> <p><input type="checkbox"/> Yes <input type="checkbox"/> No</p> <p>Measurement:</p> <p>N/A</p>		<p>Photo #:</p>	<ul style="list-style-type: none"> • Alter table or work surface • Add accessible table or work surface •

Seating: General – reception areas, waiting rooms, etc.

2.68 Is there at least one space at least 36 inches wide by at least 48 inches long for a person in a wheelchair?
[802.1.2, 802.1.3]

Yes No

Measurement:
+36"
+48"

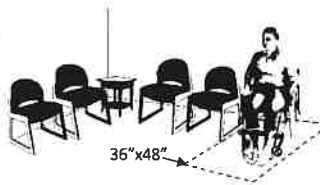

Photo #:

- Move furniture and equipment to provide space
-
-

Benches – In locker rooms, dressing rooms, fitting rooms This section does not apply to any other benches.

2.69 In locker rooms, dressing rooms and fitting rooms, is there at least one room with a bench?
[222.1, 803.4]

Yes No

N/A

Photo #:

- Add bench
-
-

2.70 Is there a clear floor space at least 30 inches wide by at least 48 inches long at the end of the bench and parallel to the short axis of the bench?

Yes No

Measurement:
N/A

Is the bench seat at least 42 inches long and no less than 20 inches and no greater than 24 inches deep?

Yes No

Measurement:
N/A

Does the bench have back support or is it affixed to a wall?

Yes No

N/A

Is the top of the bench seat no less than 17 inches and no greater than 19 inches above the floor?
[903]

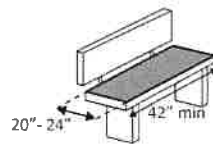
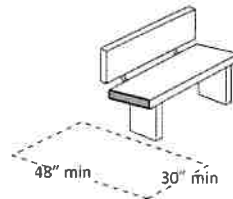

Yes No

Measurement:
N/A

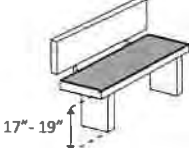
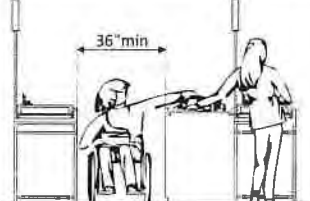
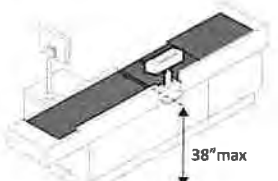
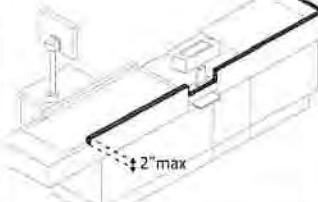

- Move bench
- Replace bench
- Affix bench to wall
-
-

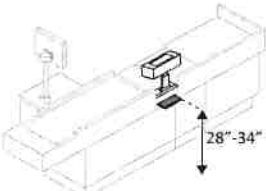
			Photo #:	
Check-Out Aisles – supermarkets, large retail stores, etc.				
<p>2.71 Is the aisle at least 36 inches wide? [904.3.1]</p>	<p><input type="checkbox"/> Yes <input type="checkbox"/> No</p> <p>Measurement: N/A</p>		Photo #:	<ul style="list-style-type: none"> • Widen aisle • •
<p>2.72 Is the counter surface of at least one aisle no higher than 38 inches above the floor? [904.3.2]</p>	<p><input type="checkbox"/> Yes <input type="checkbox"/> No</p> <p>Measurement: N/A</p>		Photo #:	<ul style="list-style-type: none"> • Lower counter • •
<p>2.73 Is the top of the counter edge protection no higher than 2 inches above the counter surface? [904.3.2]</p>	<p><input type="checkbox"/> Yes <input type="checkbox"/> No</p> <p>Measurement: N/A</p>		Photo #:	<ul style="list-style-type: none"> • Lower edge protection • •

<p>2.74 If there is a check writing surface, is the top no less than 28 inches and no greater than 34 inches above the floor? [904.3.3]</p>	<p><input type="checkbox"/> Yes <input type="checkbox"/> No</p> <p>Measurement: N/A</p>		<p>Photo #:</p>	<ul style="list-style-type: none"> • Alter check writing surface • •
<p>2.75 If there is more than one check-out aisle is there a sign with the International Symbol of Accessibility at the accessible aisle? [216.11]</p>	<p><input type="checkbox"/> Yes <input type="checkbox"/> No</p> <p>Measurement: N/A</p>		<p>Photo #:</p>	<ul style="list-style-type: none"> • Add sign • •

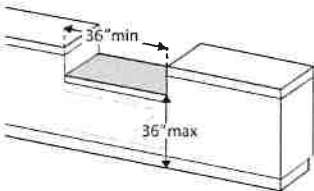
Sales & Service Counters – banks, stores, dry cleaners, auto repair shops, fitness clubs, etc.				
<p>2.76 Is there a portion of at least one of each type of counter that is:</p> <p>No higher than 36 inches above the floor?</p> <p>At least 36 inches long? [904.4.1]</p>	<p><input type="checkbox"/> Yes <input type="checkbox"/> No</p> <p>Measurement: N/A</p> <p><input type="checkbox"/> Yes <input type="checkbox"/> No</p> <p>Measurement: N/A</p>		<p>Photo #:</p>	<ul style="list-style-type: none"> • Lower section of counter • Lengthen section of counter •

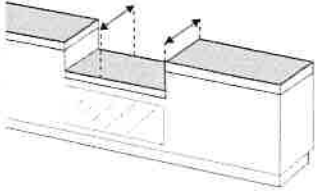
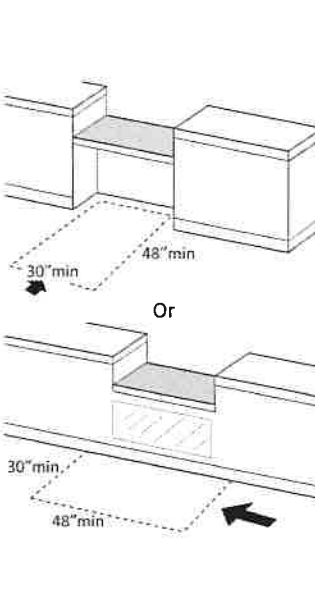
<p>2.77 Does the accessible portion of the counter extend the same depth as the counter top? [904.4]</p>	<p><input type="checkbox"/> Yes <input type="checkbox"/> No</p> <p>Measurement:</p> <p>N/A</p>		<p>Photo #:</p>	<ul style="list-style-type: none"> • Alter accessible portion • •
<p>2.78 Is there a clear floor space at least 30 inches wide by at least 48 inches long for a forward or parallel approach? [904.4]</p>	<p><input type="checkbox"/> Yes <input type="checkbox"/> No</p> <p><input type="checkbox"/> Parallel</p> <p>Measurement:</p> <p><input type="checkbox"/> Forward</p> <p>Measurement:</p> <p>N/A</p>		<p>Photo #:</p>	<ul style="list-style-type: none"> • Reconfigure to provide a parallel or forward approach • •

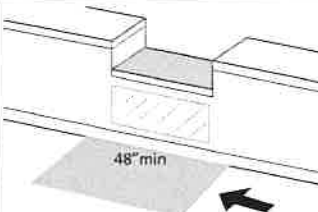
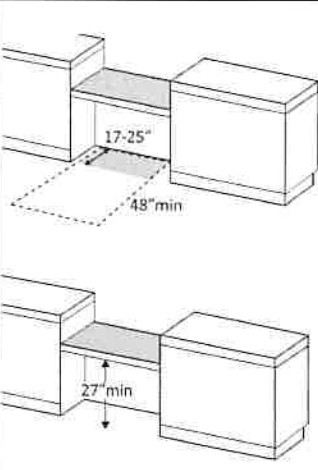
<p>2.79 For a parallel approach, is the clear floor space positioned with the 48 inches adjacent to the accessible length of counter? [904.4.1]</p>	<p><input type="checkbox"/> Yes <input type="checkbox"/> No Measurement: NA</p>		<p>Photo #:</p>	<ul style="list-style-type: none"> • If a parallel approach is not possible, a forward approach is required • •
<p>2.80 For a forward approach: Do no less than 17 and no greater than 25 inches of the clear floor space extend under the accessible length of the counter? [306.2.2, 306.2.3]</p> <p>Is there at least 27 inches clearance from the floor to the bottom of the counter? [306.3.1]</p>	<p><input type="checkbox"/> Yes <input type="checkbox"/> No Measurement: NA</p> <p><input type="checkbox"/> Yes <input type="checkbox"/> No Measurement: NA</p>		<p>Photo #:</p>	<ul style="list-style-type: none"> • Reconfigure to provide knee clearance • •

Food Service Lines – in cafeterias, salad bars, eat-in fast food establishments, etc.

2.81 Does at least one of each type of self-service shelf or dispensing device for tableware, dishware, condiments, food and beverages have a forward or parallel approach? [904.5.1]

- Yes No
- Forward
- Parallel

NA

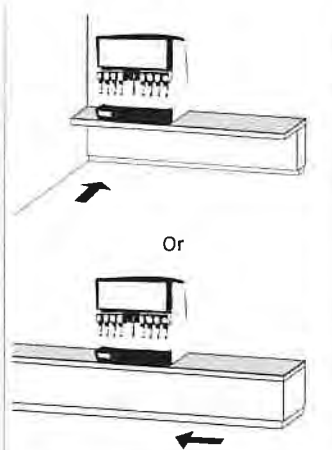

Photo #:

- Reconfigure to provide approach
-
-

2.82 If there is an unobstructed parallel approach, is the shelf or dispensing device no higher than 48 inches above the floor? [308.3.1]

- Yes No
- Measurement:

NA

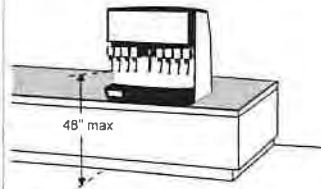

Photo #:

- Lower shelf and/or dispensing device
-
-

2.83 If there is a shallow obstruction no deeper than 10 inches with a parallel approach, is the shelf or dispensing device no higher than 48 inches above the floor? [308.3.1]

- Yes No
- Measurement:

NA

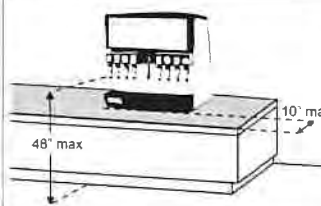
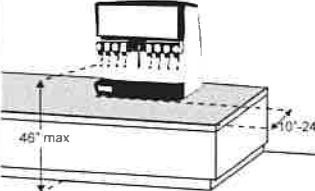
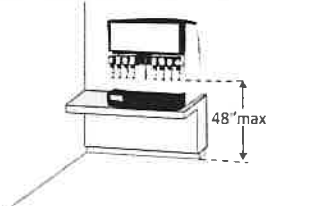
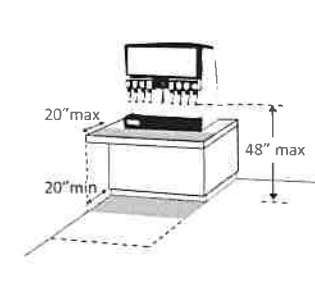
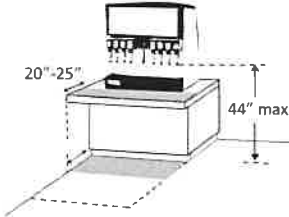
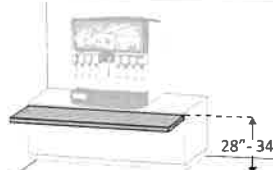

Photo #:

- Lower shelf and/or dispensing device
-
-

<p>2.84 If there is an obstruction no less than 10 inches and no greater than 24 inches deep with a parallel approach, is the shelf or dispensing device no higher than 46 inches above the floor? [308.3.2]</p>	<p><input type="checkbox"/> Yes <input type="checkbox"/> No Measurement: N/A</p>		<p>Photo #:</p>	<ul style="list-style-type: none"> • Lower shelf and/or dispensing device • •
<p>2.85 If there is an unobstructed forward approach, is the shelf or dispensing device no higher than 48 inches above the floor? [308.2.1]</p>	<p><input type="checkbox"/> Yes <input type="checkbox"/> No Measurement: N/A</p>		<p>Photo #:</p>	<ul style="list-style-type: none"> • Lower shelf and/or dispensing device • •
<p>2.86 If there is an obstruction no deeper than 20 inches with a forward approach: Does clear floor space extend under the obstruction that is at least the same depth as the obstruction? Is the shelf or dispensing device no higher than 48 inches above the floor? [904.5.1]</p>	<p><input type="checkbox"/> Yes <input type="checkbox"/> No Measurement: N/A <input type="checkbox"/> Yes <input type="checkbox"/> No Measurement: N/A</p>		<p>Photo #:</p>	<ul style="list-style-type: none"> • Reconfigure to provide knee space • Lower shelf and/or dispensing device •

<p>2.87 If the obstruction is no less than 20 inches and no greater than 25 inches deep with a forward approach:</p> <p>Does clear floor space extend under the obstruction that is at least the same depth as the obstruction?</p> <p>Is the shelf or dispensing device no higher than 44 inches above the floor? [904.5.1]</p>	<p><input type="checkbox"/> Yes <input type="checkbox"/> No</p> <p>Measurement: <i>NA</i></p> <p><input type="checkbox"/> Yes <input type="checkbox"/> No</p> <p>Measurement: <i>NA</i></p>		<p>Photo #:</p> <ul style="list-style-type: none"> • Reconfigure to provide knee space • Lower shelf and/or dispensing device •
<p>2.88 If there is a tray slide, is the top no less than 28 inches and no greater than 34 inches above the floor? [904.5.2]</p>	<p><input type="checkbox"/> Yes <input type="checkbox"/> No</p> <p>Measurement: <i>NA</i></p>		<p>Photo #:</p> <ul style="list-style-type: none"> • Reconfigure • •
	<p><input type="checkbox"/> Yes <input type="checkbox"/> No</p> <p><i>NA</i></p>		<p>Photo #:</p> <ul style="list-style-type: none"> • • •
	<p><input type="checkbox"/> Yes <input type="checkbox"/> No</p> <p><i>NA</i></p>		<p>Photo #:</p> <ul style="list-style-type: none"> • • •

The ADA Checklist for Existing Facilities

Priority 3 - Toilet Rooms

Based on the 2010 ADA Standards for Accessible Design

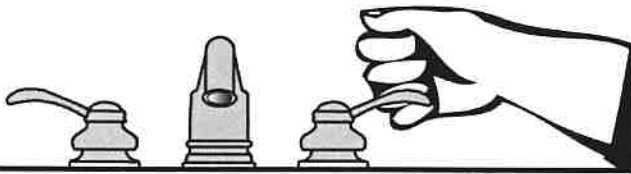

Project ADA TRANSITION PLAN

Building PUBLIC WORKS BUILDING

Location WEAVERVILLE N.C.

Date 4-20-2020

Surveyors ALAN F. MACKLEY

Contact Information DALE PERDUELL

When toilet rooms are open to the public they should be accessible to people with disabilities.



Institute for Human Centered Design
www.HumanCenteredDesign.org
Copyright © 2016



ADA National Network
Questions on the ADA 800-949-4232 voice/tty
www.ADAchecklist.org

84

This checklist was produced by the New England ADA Center, a project of the Institute for Human Centered Design and a member of the ADA National Network. This checklist was developed under a grant from the Department of Education, NIDRR grant number H133A060092-09A. However the contents do not necessarily represent the policy of the Department of Education, and you should not assume endorsement by the Federal Government.

Questions or comments on the checklist contact the New England ADA Center at 617-695-0085 voice/tty or ADAinfo@NewEnglandADA.org

For the full set of checklists, including the checklists for recreation facilities visit www.ADAchecklist.org.

Copyright © 2016 ADA Checklist for Existing Materials. You can freely reproduce and distribute this content. Include proper attribution. But you must get permission before using this content as a fee-based product.



Priority 3 – Toilet Rooms		Comments	Possible Solutions
<p>3.1 If toilet rooms are available to the public, is at least one toilet room accessible? (Either one for each sex, or one unisex.)</p> <p>Note: If toilet rooms are chiefly for children, e.g., in elementary schools and day care centers, use the children’s specifications in Toilets - 604.1, 604.8, 604.9, 609.4 and Lavatories and Sinks – 606.2.</p>	<input checked="" type="checkbox"/> Yes <input type="checkbox"/> No	<p>Photo #:</p>	<ul style="list-style-type: none"> • Reconfigure toilet rooms • Combine toilet rooms to create one unisex accessible toilet room
<p>3.2 Are there signs at inaccessible toilet rooms that give directions to accessible toilet rooms? [See 2010 ADA Standards for Accessible Design – 216.8]</p>	<input checked="" type="checkbox"/> Yes <input type="checkbox"/> No	 <p>Photo #:</p>	<ul style="list-style-type: none"> • Install signs
<p>3.3 If not all toilet rooms are accessible, is there a sign at the accessible toilet room with the International Symbol of Accessibility? [216.8]</p>	<input type="checkbox"/> Yes <input type="checkbox"/> No NA	 <p>Photo #:</p>	<ul style="list-style-type: none"> • Install sign
Accessible Route			
<p>3.4 Is there an accessible route to the accessible toilet room? [206.2.4]</p>	<input checked="" type="checkbox"/> Yes <input type="checkbox"/> No		<ul style="list-style-type: none"> • Alter route

Photo #:

Signs at Toilet Rooms

3.5 Do text characters contrast with their backgrounds? [703.5]

Yes No

Are text characters raised? [703.2]

Yes No

Is there Braille? [703.3]

Yes No

Is the sign mounted: On the wall on the latch side of the door? [703.4.2]

Yes No

Note: Signs are permitted on the push side of doors with closers and without hold-open devices.

With clear floor space beyond the arc of the door swing and 45-degree open position, at least 18 x 18 inches centered on the tactile characters? * [703.4.2]

Yes No

Measurement: 10"

So the baseline of the lowest character is at least 48 inches above the floor and the

Yes No
Measurement: 56"

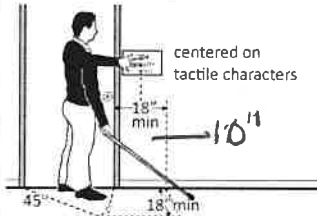
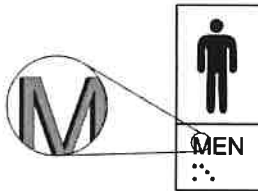

- Install tactile sign
- Relocate sign
-

*If constructed before 3/15/2012 and a person may approach within 3 inches of the sign without encountering protruding objects or standing within the door swing, relocation not required

ADA Checklist for Existing Facilities

Priority 3 – Toilet Rooms

baseline of the highest character is no more than 60 inches above the floor? * [703.4.1]

Note: If the sign is at double doors with one active leaf, the sign should be on the inactive leaf; if both leaves are active, the sign should be on the wall to the right of the right leaf.

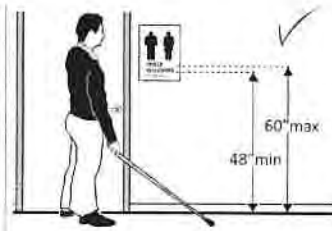

Photo #:

*If constructed before 3/15/2012 and mounted no higher than 60 inches to the centerline of the sign, relocation is not required

Entrance

3.6 Is the door opening width at least 32 inches clear, between the face of the door and the stop, when the door is open 90 degrees? [404.2.3]

Yes No

Measurement:

33"

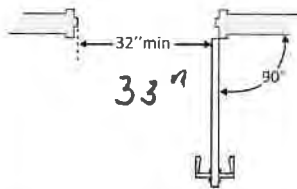

Photo #:

- Install offset hinges
- Alter the doorway

3.7 If there is a front approach to the pull side of the door is there at least 18 inches of maneuvering clearance beyond the latch side plus 60 inches clear depth?

Yes No

Measurement:

22"

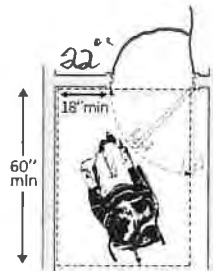

Photo #:

- Remove obstructions
- Reconfigure walls
- Add automatic door opener



Note: See 2010 Standards 404.2.4 for maneuvering clearance requirements on the push side of the door and side approaches to the pull side of the door

On both sides of the door, is the

ADA Checklist for Existing Facilities

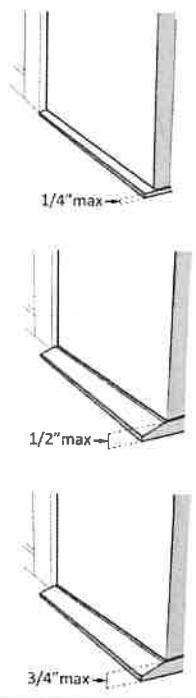
Priority 3 – Toilet Rooms

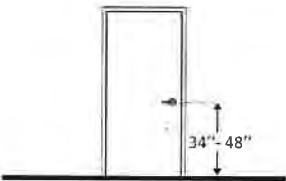
<p>floor surface of the maneuvering clearance level (no steeper than 1:48)? [404.2.4]</p>	<p><input checked="" type="checkbox"/> Yes <input type="checkbox"/> No Measurement: 0"</p>		<p>Photo #:</p>	
<p>3.8 If the threshold is vertical is it no more than ¼ inch high? Or No more than ½ inch high with the top ¼ inch beveled no steeper than 1:2, if the threshold was installed on or after the 1991 ADA Standards went into effect (1/26/93)? Or No more than ¾ inch high with the top ¼ inch beveled no steeper than 1:2, if the threshold was installed before the 1991 ADA Standards went into effect (1/26/93)? [404.2.5, 303.2] Note: The first ¼ inch of the ½ or ¾ inch threshold may be vertical; the rest must be beveled.</p>	<p><input type="checkbox"/> Yes <input type="checkbox"/> No Measurement: NO <input type="checkbox"/> Yes <input type="checkbox"/> No Measurement: N/A <input type="checkbox"/> Yes <input type="checkbox"/> No Measurement: N/A</p>		<p>Photo #:</p>	<ul style="list-style-type: none"> • Remove or replace threshold • •

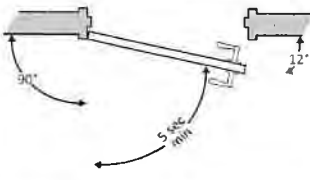
<p>3.9 Is the door equipped with hardware that is operable with one hand and does not require tight grasping, pinching or twisting of the wrist? Door handle? Lock (if provided)? [404.2.7]</p>	<p><input checked="" type="checkbox"/> Yes <input type="checkbox"/> No <input checked="" type="checkbox"/> Yes <input type="checkbox"/> No <input checked="" type="checkbox"/> Yes <input type="checkbox"/> No</p>		<p>Photo #:</p>	<ul style="list-style-type: none"> • Replace inaccessible knob with lever, loop or push hardware • Add automatic door opener
<p>3.10 Are the operable parts of the door hardware mounted no less than 34 inches and no greater than 48 inches above the floor? [404.2.7]</p>	<p><input checked="" type="checkbox"/> Yes <input type="checkbox"/> No Measurement: 39 1/2</p>		<p>Photo #:</p>	<ul style="list-style-type: none"> • Change hardware height
<p>3.11 Can the door be opened easily (5 pounds maximum force)? [404.2.9] Note: You can use a pressure gauge or fish scale to measure force. If you do not have one you will need to judge whether the door is easy to open.</p>	<p><input checked="" type="checkbox"/> Yes <input type="checkbox"/> No Measurement: 5 lbs</p>		<p>Photo #:</p>	<ul style="list-style-type: none"> • Adjust or replace closers • Install lighter doors • Install power-assisted or automatic door openers
<p>3.12 If the door has a closer, does it take at least 5 seconds to close from an open position of 90 degrees to a position of 12 degrees from the latch? [404.2.8.1]</p>	<p><input type="checkbox"/> Yes <input checked="" type="checkbox"/> No Measurement: 2.5 sec.</p>		<p>Photo #:</p>	<ul style="list-style-type: none"> • Adjust closer

<p>3.13 If there are two doors in a series, e.g. vestibule, is the distance between the doors at least 48 inches plus the width of the doors when swinging into the space? [404.2.6]</p>	<p><input type="checkbox"/> Yes <input type="checkbox"/> No</p> <p>Measurement:</p> <p><i>NA</i></p>	<p>48" min</p> <p>or</p> <p>48" min</p> <p>or</p> <p>48" min</p>	<p>Photo #:</p> <ul style="list-style-type: none"> • Remove inner door • Change door swing •
<p>3.14 If there is a privacy wall and the door swings out, is there at least 24 inches of maneuvering clearance beyond the door latch side and 42 inches to the privacy wall? [404.2.4]</p>	<p><input type="checkbox"/> Yes <input type="checkbox"/> No</p> <p>Measurement:</p> <p><i>NA</i></p>	<p>24" min</p> <p>48" min</p> <p>42" min</p> <p>privacy wall</p>	<p>Photo #:</p> <ul style="list-style-type: none"> • Reconfigure space • •

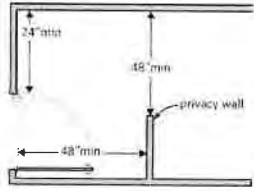
<p>3.15 If there is a privacy wall and the door swings in, is there at least 24 inches of maneuvering clearance beyond the door latch side and at least 48 inches to the privacy wall if there is no door closer or at least 54 inches if there is a door closer? [404.2.4]</p>	<p><input type="checkbox"/> Yes <input type="checkbox"/> No Measurement: NA</p>		<p>Photo #:</p>	<ul style="list-style-type: none"> • Reconfigure space • •
---------------------------------------------------------------------------------------------------------------------------------------------------------------------------------------------------------------------------------------------------------------------------------	---------------------------------------------------------------------------------------------------------------------------	-----------------------------------------------------------------------------------	-----------------	---------------------------------------------------------------------------------------------

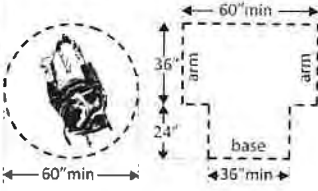
In the Toilet Room				
<p>3.16 Is there a clear path to at least one of each type of fixture, e.g. lavatory, hand dryer, etc., that is at least 36 inches wide? [403.5.1]</p>	<p><input checked="" type="checkbox"/> Yes <input type="checkbox"/> No Measurement: +36"</p>		<p>Photo #:</p>	<ul style="list-style-type: none"> • Remove obstructions • •
<p>3.17 Is there clear floor space available for a person in a wheelchair to turn around, i.e. a circle at least 60 inches in diameter or a T-shaped space within a 60-inch square? [603.2.1]</p>	<p><input checked="" type="checkbox"/> Yes <input type="checkbox"/> No Measurement: +60"</p>		<p>Photo #:</p>	<ul style="list-style-type: none"> • Move or remove partitions, fixtures or objects such as trash cans • •

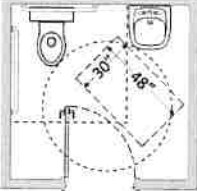
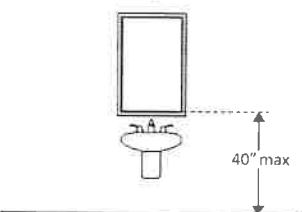
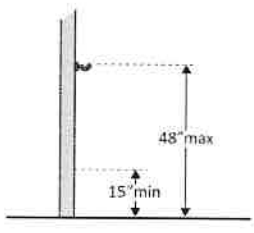
<p>3.18 In a single user toilet room if the door swings in and over a clear floor space at an accessible fixture, is there a clear floor space at least 30 x 48 inches beyond the swing of the door? [603.2.3 Exception 2]</p>	<p><input checked="" type="checkbox"/> Yes <input type="checkbox"/> No Measurement: +30" +48"</p>		<p>Photo #:</p>	<ul style="list-style-type: none"> • Reverse door swing • Alter toilet room •
<p>3.19 If the mirror is over a lavatory or countertop, is the bottom edge of the reflecting surface no higher than 40 inches above the floor? Or If the mirror is not over the lavatory or countertop, is the bottom edge of the reflecting surface no higher than 35 inches above the floor?*[603.3]</p>	<p><input checked="" type="checkbox"/> Yes <input type="checkbox"/> No Measurement: 40" <input type="checkbox"/> Yes <input type="checkbox"/> No Measurement: NA</p>		<p>Photo #:</p>	<ul style="list-style-type: none"> * If installed before 3/15/2012 and the bottom edge of the reflecting surface is no higher than 40 inches above the floor, lowering the mirror to 35 inches is not required • Lower the mirror • Add another mirror •
<p>3.20 If there is a coat hook, is it no less than 15 inches and no greater than 48 inches above the floor?*[603.4]</p> <p>NA</p>	<p><input type="checkbox"/> Yes <input type="checkbox"/> No Measurement: NA</p>		<p>Photo #:</p>	<ul style="list-style-type: none"> • Adjust hook • Replace with or provide additional accessible hook • * If installed before 3/15/2010 and the clear floor space allows a parallel approach, the coat hook may be 54 inches above the floor.

Lavatories The 2010 Standards refer to sinks in toilet rooms as lavatories.

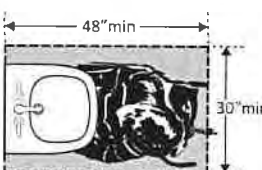
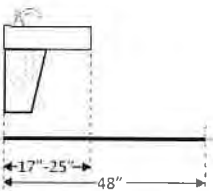
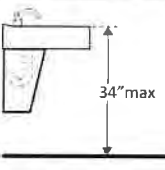
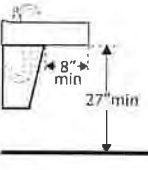
<p>3.21 Does at least one lavatory have a clear floor space for a forward approach at least 30 inches wide and 48 inches long? [606.2]</p>	<p><input checked="" type="checkbox"/> Yes <input type="checkbox"/> No Measurement: 30" WIDE 48" LONG</p>		<p>Photo #:</p>	<ul style="list-style-type: none"> • Alter lavatory • Replace lavatory
<p>3.22 Do no less than 17 inches and no greater than 25 inches of the clear floor space extend under the lavatory so that a person using a wheelchair can get close enough to reach the faucet? [306.2]</p>	<p><input checked="" type="checkbox"/> Yes <input type="checkbox"/> No Measurement: 17"</p>		<p>Photo #:</p>	<ul style="list-style-type: none"> • Alter lavatory • Replace lavatory
<p>3.23 Is the front of the lavatory or counter surface, whichever is higher, no more than 34 inches above the floor? [606.3]</p>	<p><input checked="" type="checkbox"/> Yes <input type="checkbox"/> No Measurement: 33"</p>		<p>Photo #:</p>	<ul style="list-style-type: none"> • Alter lavatory • Replace lavatory
<p>3.24 Is there at least 27 inches clearance from the floor to the bottom of the lavatory that extends at least 8 inches under the lavatory for knee clearance? [306.3.3]</p>	<p><input checked="" type="checkbox"/> Yes <input type="checkbox"/> No Measurement: 30"</p>		<p>Photo #:</p>	<ul style="list-style-type: none"> • Alter lavatory • Replace lavatory

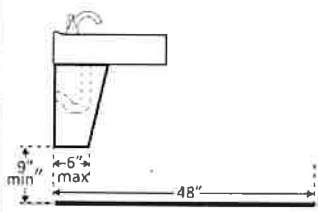
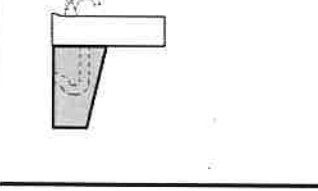
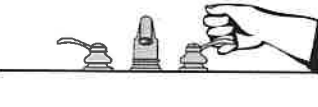
<p>3.25 Is there toe clearance at least 9 inches high? [306.3.3]</p> <p>Note: Space extending greater than 6 inches beyond the available toe clearance at 9 inches above the floor is not considered toe clearance.</p>	<p><input checked="" type="checkbox"/> Yes <input type="checkbox"/> No</p>		<p>Photo #:</p>	<ul style="list-style-type: none"> • Alter lavatory • Replace lavatory •
<p>3.26 Are pipes below the lavatory insulated or otherwise configured to protect against contact? [606.5]</p>	<p><input type="checkbox"/> Yes <input checked="" type="checkbox"/> No</p>		<p>Photo #:</p>	<ul style="list-style-type: none"> • Install insulation • Install cover panel •
<p>3.27 Can the faucet be operated without tight grasping, pinching, or twisting of the wrist?</p> <p>Is the force required to activate the faucet no greater than 5 pounds? [606.4]</p>	<p><input checked="" type="checkbox"/> Yes <input type="checkbox"/> No</p> <p><input type="checkbox"/> Yes <input type="checkbox"/> No</p>		<p>Photo #:</p>	<ul style="list-style-type: none"> • Adjust faucet • Replace faucet •

Soap Dispensers and Hand Dryers

ADA Checklist for Existing Facilities

Priority 3 – Toilet Rooms

3.28 Are the operable parts of the soap dispenser within one of the following reach ranges:

Above lavatories or counters no less than 20 inches and no greater than 25 inches deep: no higher than 44 inches above the floor?
[308.2.2]

Yes No

Measurement:

17"

41"

Above lavatories less than 20 inches deep: no higher than 48 inches above the floor?

Yes No

Measurement:

41"

Not over an obstruction: no higher than 48 inches above the floor?
[308.2]

Yes No

Measurement:

41"

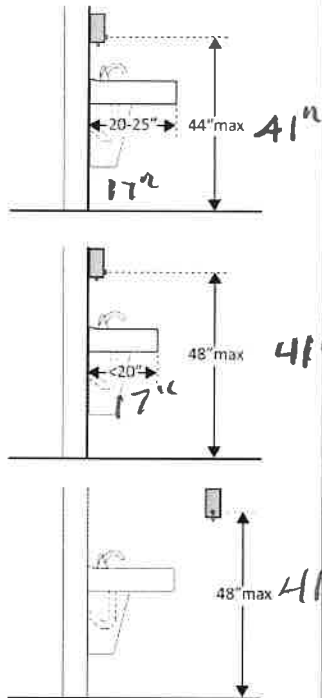

Photo #:

- Adjust dispensers
- Replace with or provide additional accessible dispensers

<p>3.29 Are the operable parts of the hand dryer or towel dispenser within one of the following reach ranges:</p> <p>Above lavatories or counters no less than 20 inches and no greater than 25 inches deep: no higher than 44 inches above the floor?</p> <p>Above lavatories less than 20 inches deep: no higher than 48 inches above the floor?</p> <p>Not over an obstruction: no higher than 48 inches above the floor? [308.2]</p> <p>Can the operable parts of the hand dryer or towel dispenser be operated without tight grasping, pinching or twisting of the wrist?</p> <p>Is the force required to activate the hand dryer or towel dispenser no greater than 5 pounds? [309.4]</p>	<p><input checked="" type="checkbox"/> Yes <input type="checkbox"/> No Measurement: 17" 44"</p> <p><input checked="" type="checkbox"/> Yes <input type="checkbox"/> No Measurement: 48"</p> <p><input checked="" type="checkbox"/> Yes <input type="checkbox"/> No Measurement:</p> <p><input checked="" type="checkbox"/> Yes <input type="checkbox"/> No Measurement: 48</p>		<p>Photo #:</p> <ul style="list-style-type: none"> • Adjust dispensers • Replace with or provide additional accessible dispensers
--------------------------------------------------------------------------------------------------------------------------------------------------------------------------------------------------------------------------------------------------------------------------------------------------------------------------------------------------------------------------------------------------------------------------------------------------------------------------------------------------------------------------------------------------------------------------------------------------------------------------------------------------------------------------------------------------------	------------------------------------------------------------------------------------------------------------------------------------------------------------------------------------------------------------------------------------------------------------------------------------------------------------------------------------------------------------------------------------------------	--	-----------------------------------------------------------------------------------------------------------------------------------------------------------

Water Closets in Single-User Toilet Rooms and Compartments (Stalls) The 2010 Standards refer to toilets as water closets.

ADA Checklist for Existing Facilities

Priority 3 – Toilet Rooms

3.30 Is the centerline of the water closet no less than 16 inches and no greater than 18 inches from the side wall or partition? [604.2]

Yes No

Measurement:

18"



Photo #:

- Move toilet
- Replace toilet
- Move partition
-

3.31 Is clearance provided around the water closet measuring at least 60 inches from the side wall and at least 56 inches from the rear wall?* [604.3.1]

Yes No

Measurement:

56"
62"

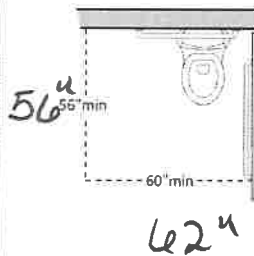

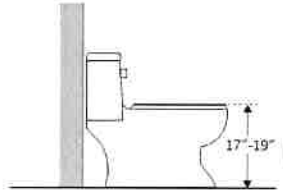
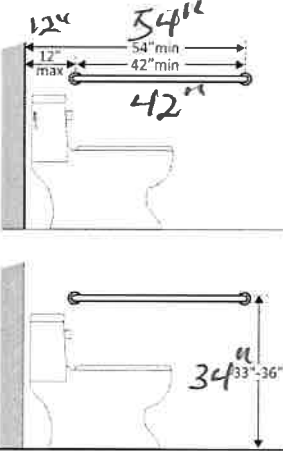

* If constructed before 3/15/12, clearances around water closets in single user toilet rooms can be 48 inches wide by 66 inches long or 48 inches wide by 56 inches long (depending on the approach to the water closet, see 1991 Standards Figure 28) and the lavatory may overlap that clearance if the door to the room does not swing into the required clearances at fixtures (such as lavatories, water closet and urinals) and the edge of the lavatory is at least 18 inches from the centerline of the water closet

- Alter room/compartment for clearance
-
-

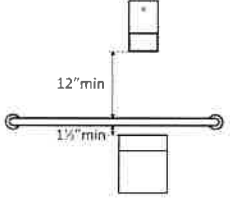
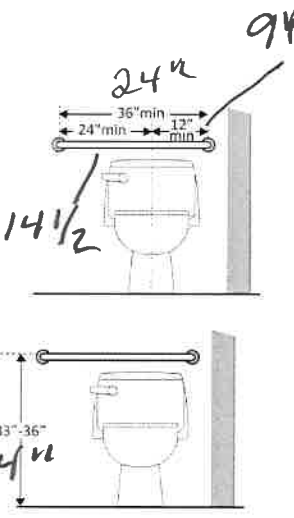
			Photo #:	
<p>3.32 Is the height of the water closet no less than 17 inches and no greater than 19 inches above the floor measured to the top of the seat? [604.4]</p>	<p><input type="checkbox"/> Yes <input type="checkbox"/> No Measurement: 17"</p>		Photo #:	<ul style="list-style-type: none"> • Adjust toilet height • Replace toilet
<p>3.33 Is there a grab bar at least 42 inches long on the side wall?</p> <p>Is it located no more than 12 inches from the rear wall?</p> <p>Does it extend at least 54 inches from the rear wall? [604.5.1]</p> <p>Is it mounted no less than 33 inches and no greater than 36 inches above the floor to the top of the gripping surface? [609.4]</p> <p>Is there at least 12 inches clearance between the grab bar</p>	<p><input checked="" type="checkbox"/> Yes <input type="checkbox"/> No Measurement: 42"</p> <p><input checked="" type="checkbox"/> Yes <input type="checkbox"/> No Measurement: 12"</p> <p><input checked="" type="checkbox"/> Yes <input type="checkbox"/> No Measurement: 54"</p> <p><input checked="" type="checkbox"/> Yes <input type="checkbox"/> No Measurement: 34"</p> <p><input type="checkbox"/> Yes <input type="checkbox"/> No N/A</p>			<ul style="list-style-type: none"> • Install grab bar • Relocate grab bar • Relocate objects

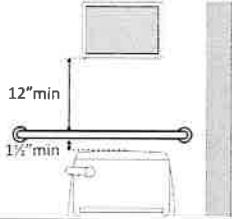
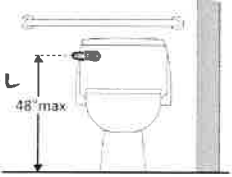
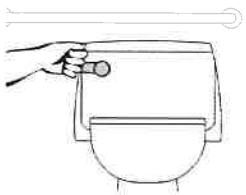
<p>and protruding objects above?*</p> <p>Is there at least 1½ inches clearance between the grab bar and projecting objects below?*</p> <p>Is the space between the wall and the grab bar 1 ½ inches? [609.3]</p>	<p>Measurement:</p> <p><input checked="" type="checkbox"/> Yes <input type="checkbox"/> No</p> <p>Measurement: 6"</p> <p><input checked="" type="checkbox"/> Yes <input type="checkbox"/> No</p> <p>Measurement: 1½"</p>		<p>Photo #:</p>	<p>* If constructed before 3/15/2012 grab bars do not need to be relocated; there are no space requirements above and below grab bars in the 1991 Standards</p>
<p>3.34 Is there a grab bar at least 36 inches long on the rear wall?</p> <p>Does it extend at least 12 inches from the centerline of the water closet on one side (side wall)?</p> <p>Does it extend at least 24 inches on the other (open) side? [604.5.2]</p> <p>Is it mounted no less than 33 inches and no greater than 36 inches above the floor to the top of the gripping surface? [609.4]</p> <p>Are there at least 12 inches clearance between the grab bar and protruding objects above?*</p> <p>Are there at least 1½ inches</p>	<p><input type="checkbox"/> Yes <input checked="" type="checkbox"/> No</p> <p>Measurement: 24"</p> <p><input type="checkbox"/> Yes <input checked="" type="checkbox"/> No</p> <p>Measurement: 10"</p> <p><input type="checkbox"/> Yes <input checked="" type="checkbox"/> No</p> <p>Measurement: 14"</p> <p><input checked="" type="checkbox"/> Yes <input type="checkbox"/> No</p> <p>Measurement: 34"</p> <p><input type="checkbox"/> Yes <input type="checkbox"/> No</p> <p>Measurement: NA</p> <p><input type="checkbox"/> Yes <input type="checkbox"/> No</p>		<p>Photo #:</p>	<ul style="list-style-type: none"> • Install grab bar • Relocate grab bar • Relocate objects • <p>* If constructed before 3/15/2012 grab bars do not need to be relocated; there are no space</p>

<p>clearance between the grab bar and projecting objects below?*</p> <p>Is the space between the wall and the grab bar 1½ inches? [609.3]</p>	<p>Measurement: NA</p> <p><input checked="" type="checkbox"/> Yes <input type="checkbox"/> No</p> <p>Measurement: 1 1/2"</p>		<p>Photo #:</p>	<p>requirements above and below grab bars in the 1991 Standards</p>
<p>3.35 If the flush control is hand operated, is the operable part located no higher than 48 inches above the floor? [604.6]</p>	<p><input type="checkbox"/> Yes <input type="checkbox"/> No</p> <p>Measurement: 25" 25"</p>		<p>Photo #:</p>	<ul style="list-style-type: none"> • Move control • Install sensor with override button no higher than 48 inches
<p>3.36 If the flush control is hand operated, can it be operated with one hand and without tight grasping, pinching, or twisting of the wrist?</p> <p>Is the force required to activate the flush control no greater than 5 pounds? [605.4]</p>	<p><input type="checkbox"/> Yes <input type="checkbox"/> No</p> <p><input type="checkbox"/> Yes <input type="checkbox"/> No</p> <p>Measurement:</p>		<p>Photo #:</p>	<ul style="list-style-type: none"> • Change control • Adjust control
<p>3.37 Is the flush control on the open side of the water closet? [604.6]</p>	<p><input checked="" type="checkbox"/> Yes <input type="checkbox"/> No</p>		<p>Photo #:</p>	<ul style="list-style-type: none"> • Move control

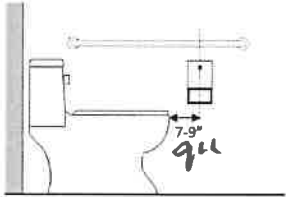
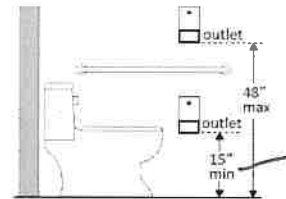
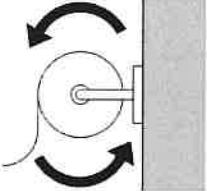
<p>3.38 Is the toilet paper dispenser located no less than 7 inches and no greater than 9 inches from the front of the water closet to the centerline of the dispenser?*</p> <p>[604.7]</p>	<p><input checked="" type="checkbox"/> Yes <input type="checkbox"/> No</p> <p>Measurement:</p> <p>9" <i>9"</i></p>		<p>Photo #:</p>	<p>* If constructed before 3/15/2012 dispenser does not need to be relocated if it is within reach from the water closet seat; the 1991 Standards do not specify distance from the front of the water closet</p> <ul style="list-style-type: none"> • Relocate dispenser • •
<p>3.39 Is the outlet of the dispenser:</p> <p>Located no less than 15 inches and no greater than 48 inches above the floor?</p> <p>Not located behind grab bars?</p> <p>[604.7]</p>	<p><input checked="" type="checkbox"/> Yes <input type="checkbox"/> No</p> <p>Measurement:</p> <p>17" <i>17"</i></p> <p><input type="checkbox"/> Yes <input type="checkbox"/> No</p>		<p>Photo #:</p>	<ul style="list-style-type: none"> • Relocate dispenser • •
<p>3.40 Does the dispenser allow continuous paper flow?</p> <p>[604.7]</p>	<p><input checked="" type="checkbox"/> Yes <input type="checkbox"/> No</p>		<p>Photo #:</p>	<ul style="list-style-type: none"> • Adjust dispenser • Replace dispenser •

Toilet Compartments (Stalls)

ADA Checklist for Existing Facilities

Priority 3 – Toilet Rooms

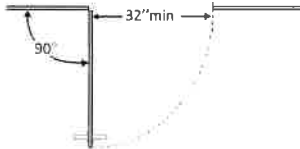
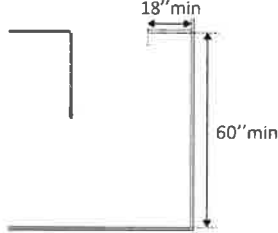
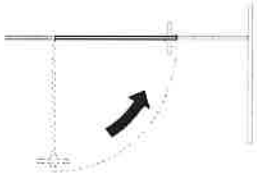
<p>3.41 Is the door opening width at least 32 inches clear, between the face of the door and the stop, when the door is open 90 degrees? [604.8.1.2]</p>	<p><input checked="" type="checkbox"/> Yes <input type="checkbox"/> No Measurement: 33"</p>	 <p>32" min 90°</p>	<p>Photo #:</p>	<ul style="list-style-type: none"> • Widen door width • •
<p>3.42 If there is a front approach to the pull side of the door, is there at least 18 inches of maneuvering clearance beyond the latch side plus 60 inches clear depth? [604.8.1.2]</p> <p>Note: See 2010 Standards 604.8.1.2 Doors for maneuvering clearance requirements on the push side of the door and side approaches to the pull side of the door</p>	<p><input checked="" type="checkbox"/> Yes <input type="checkbox"/> No Measurement: 23"</p>	 <p>18" min 60" min</p>	<p>Photo #:</p>	<ul style="list-style-type: none"> • Remove obstructions • •
<p>3.43 Is the door self-closing? [604.8.1.2]</p>	<p><input checked="" type="checkbox"/> Yes <input type="checkbox"/> No</p>		<p>Photo #:</p>	<ul style="list-style-type: none"> • Add closer • Replace door •

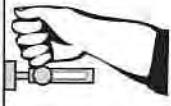
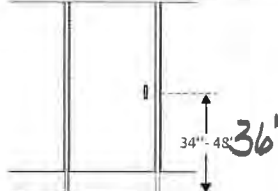
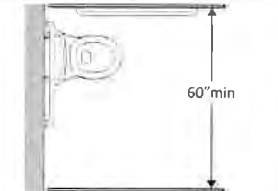
<p>3.44 Are there door pulls on both sides of the door that are operable with one hand and do not require tight grasping pinching or twisting of the wrist?*</p> <p>[604.8.1.2]</p>	<p><input checked="" type="checkbox"/> Yes <input type="checkbox"/> No</p>		<p>Photo #:</p>	<p>* If constructed before 3/15/2012 door pulls do not need to be added; door pulls are not required in the 1991 Standards</p> <ul style="list-style-type: none"> • Replace hardware • •
<p>3.45 Is the lock operable with one hand and without tight grasping, pinching or twisting of the wrist?</p> <p>[309.4]</p>	<p><input checked="" type="checkbox"/> Yes <input type="checkbox"/> No</p>		<p>Photo #:</p>	<ul style="list-style-type: none"> • Replace lock • •
<p>3.46 Are the operable parts of the door hardware mounted no less than 34 inches and no greater than 48 inches above the floor?</p> <p>[404.2.7]</p>	<p><input checked="" type="checkbox"/> Yes <input type="checkbox"/> No</p> <p>Measurement: 36"</p>		<p>Photo #:</p>	<ul style="list-style-type: none"> • Relocate hardware • •
<p>3.47 Is the compartment at least 60 inches wide?</p> <p>[604.8.1.1]</p>	<p><input checked="" type="checkbox"/> Yes <input type="checkbox"/> No</p> <p>Measurement: 62"</p>		<p>Photo #:</p>	<ul style="list-style-type: none"> • Widen compartment • •

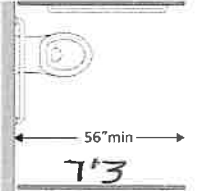
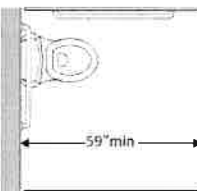
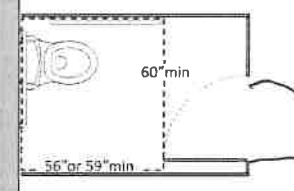
<p>3.48 If the water closet is wall hung, is the compartment at least 56 inches deep? [604.8.1.1]</p>	<p><input checked="" type="checkbox"/> Yes <input type="checkbox"/> No Measurement: 87"</p>		<p>Photo #:</p>	<ul style="list-style-type: none"> • Widen compartment • •
<p>3.49 If the water closet is floor mounted, is the compartment at least 59 inches deep? [604.8.1.1]</p>	<p><input type="checkbox"/> Yes <input type="checkbox"/> No Measurement: NA</p>		<p>Photo #:</p>	<ul style="list-style-type: none"> • Alter compartment • •
<p>3.50 If the door swings in, is the minimum required compartment area provided beyond the swing of the door (60 inches x 56 inches if water closet is wall hung or 59 inches if water closet is floor mounted)? [604.8.1.1]</p>	<p><input type="checkbox"/> Yes <input type="checkbox"/> No Measurement: SWINGS OUT NA</p>		<p>Photo #:</p>	<ul style="list-style-type: none"> • Reverse door swing • Alter compartment •

ADA Checklist for Existing Facilities

Priority 4 – Additional Access

Based on the 2010 ADA Standards for Accessible Design

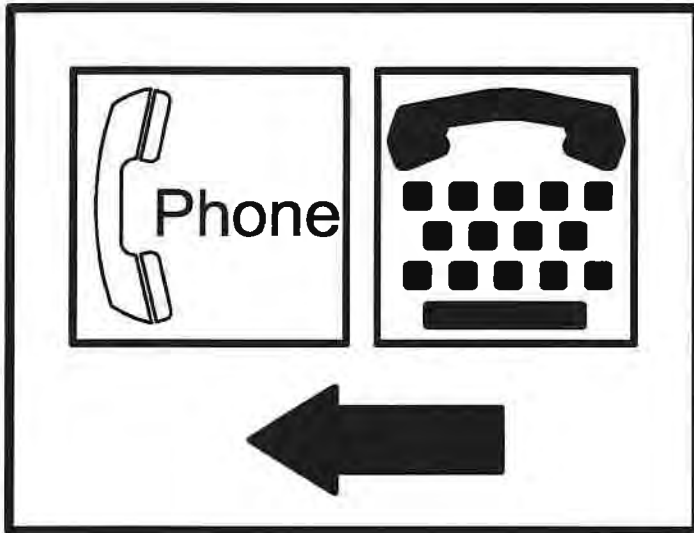

Project ADA TRANSITION PLAN

Building PUBLIC WORKS BUILDING

Location WEAVERVILLE NC

Date 4-20-2020

Surveyors ALAN F. MACKLEY

Contact Information DALE PENNELL

Amenities such as drinking fountains and public telephones should be accessible to people with disabilities.



Institute for Human Centered Design
www.HumanCenteredDesign.org
Copyright © 2016



ADA National Network
Questions on the ADA 800-949-4232 voice/tty
www.ADAchecklist.org

This checklist was produced by the New England ADA Center, a project of the Institute for Human Centered Design and a member of the ADA National Network. This checklist was developed under a grant from the Department of Education, NIDRR grant number H133A060092-09A. However the contents do not necessarily represent the policy of the Department of Education, and you should not assume endorsement by the Federal Government.

Questions or comments on the checklist contact the New England ADA Center at 617-695-0085 voice/tty or ADAinfo@NewEnglandADA.org

For the full set of checklists, including the checklists for recreation facilities visit www.ADAchecklist.org.

Copyright © 2016 ADA Checklist for Existing Materials. You can freely reproduce and distribute this content. Include proper attribution. But you must get permission before using this content as a fee-based product.

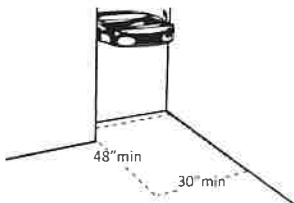
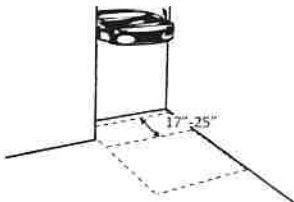
Priority 4 – Additional Access		Comments	Possible Solutions
Drinking Fountains			
<p>4.1 Does at least one drinking fountain have a clear floor space at least 30 inches wide x at least 48 inches long centered in front of it for a forward approach?*</p> <p>[See 2010 ADA Standards for Accessible Design – 602.2]</p>	<p><input checked="" type="checkbox"/> Yes <input type="checkbox"/> No</p> <p>Measurement: +48" +30"</p>		<p>Photo #:</p> <p>*If installed before 3/15/2012, a parallel approach is permitted and the clear floor space is not required to be centered</p> <ul style="list-style-type: none"> • Alter space • Relocate drinking fountain • Install a drinking fountain in another location
<p>4.2 If there is a forward approach, do no less than 17 inches and no greater than 25 inches of the clear floor space extend under the drinking fountain?</p> <p>[306.2.2, 306.2.3]</p> <p>Note: If the drinking fountain is primarily for children’s use and the spout is no more than 30 inches above the floor and no more than 3 ½ inches from the edge of the unit, a parallel approach is permitted.</p>	<p><input checked="" type="checkbox"/> Yes <input type="checkbox"/> No</p> <p>Measurement: 19"</p>		<p>Photo #:</p> <ul style="list-style-type: none"> • Alter space • Replace drinking fountain •

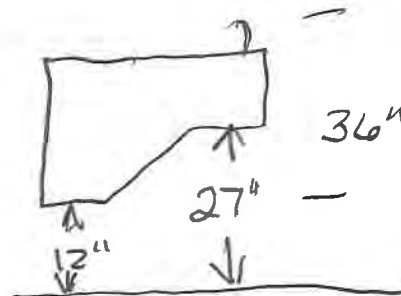

ADA Checklist for Existing Facilities

Priority 4 – Additional Access

<p>4.3 If the drinking fountain is no deeper than 20 inches, are the operable parts no higher than 48 inches above the floor? [308.2.2]</p>	<p><input checked="" type="checkbox"/> Yes <input type="checkbox"/> No Measurement: 19" 36"</p>		<p>Photo #:</p>	<ul style="list-style-type: none"> • Adjust drinking fountain • Replace drinking fountain
<p>4.4 If the drinking fountain is no less than 20 inches and no greater than 25 inches deep, are the operable parts no higher than 44 inches above the floor? [308.2.2]</p>	<p><input checked="" type="checkbox"/> Yes <input type="checkbox"/> No Measurement: 30"</p>		<p>Photo #:</p>	<ul style="list-style-type: none"> • Adjust drinking fountain • Replace drinking fountain
<p>4.5 Can the control be operated with one hand and without tight grasping, pinching or twisting of the wrist? Is the force required to activate the control no more than 5 pounds? [309.4]</p>	<p><input checked="" type="checkbox"/> Yes <input type="checkbox"/> No <input checked="" type="checkbox"/> Yes <input type="checkbox"/> No Measurement: 1.1 lbs</p>		<p>Photo #:</p>	<ul style="list-style-type: none"> • Change control • Adjust control
<p>4.6 Is the spout outlet no higher than 36 inches above the floor? [602.4]</p>	<p><input type="checkbox"/> Yes <input type="checkbox"/> No Measurement: 36"</p>		<p>Photo #:</p>	<ul style="list-style-type: none"> • Adjust drinking fountain • Replace drinking fountain

<p>4.7 Is the spout:</p> <p>At least 15 inches from the rear of the drinking fountain?</p> <p>No more than 5 inches from the front of the drinking fountain? [602.5]</p>	<p><input checked="" type="checkbox"/> Yes <input type="checkbox"/> No</p> <p>Measurement: 15"</p> <p><input checked="" type="checkbox"/> Yes <input type="checkbox"/> No</p> <p>Measurement: 4"</p>		<p>Photo #:</p>	<ul style="list-style-type: none"> • Adjust spout • Replace drinking fountain
<p>4.8 If there is more than one drinking fountain, is there at least one for standing persons? [211.2]</p> <p>Is the spout outlet no lower than 38 inches and no higher than 43 inches above the floor? [602.7]</p>	<p><input type="checkbox"/> Yes <input type="checkbox"/> No</p> <p><input checked="" type="checkbox"/> Yes <input type="checkbox"/> No</p> <p>Measurement: 36"</p>		<p>Photo #:</p>	<ul style="list-style-type: none"> • Adjust drinking fountain • Install new drinking fountain for standing height
<p>4.9 If the leading (bottom) edge of the fountain is higher than 27 inches above the floor, does the front of the fountain protrude no more than 4 inches into the circulation path? [307.2]</p>	<p><input type="checkbox"/> Yes <input checked="" type="checkbox"/> No</p> <p>Measurement: 36" 19"</p>		<p>Photo #:</p>	<ul style="list-style-type: none"> • Adjust drinking fountain • Replace drinking fountain • Add tactile warning such as permanent planter or partial walls

N/A

Public Telephones				
<p>4.10 Does at least one telephone have a clear floor space at least 30 inches wide x at least 48 inches long for a parallel or forward approach? [704.2.1]</p>	<p><input type="checkbox"/> Yes <input type="checkbox"/> No</p>		<p>Photo #:</p>	<ul style="list-style-type: none"> • Move telephone • Install new telephone for clear floor space •
<p>4.11 Is the highest operable part of the telephone no higher than 48 inches above the floor? [704.2.2]</p>	<p><input type="checkbox"/> Yes <input type="checkbox"/> No</p>	<p>Measurement:</p>	<p>Photo #:</p>	<ul style="list-style-type: none"> • Adjust telephone • •
<p>4.12 If the leading (bottom) edge of the telephone is higher than 27 inches above the floor, does the front of the telephone protrude no more than 4 inches into the circulation path? [307.2]</p>	<p><input type="checkbox"/> Yes <input type="checkbox"/> No</p>	<p>Measurement:</p>	<p>Photo #:</p>	<ul style="list-style-type: none"> • Adjust telephone • •

N/A





N/A



N/A

N/A

ADA Checklist for Existing Facilities

Priority 4 – Additional Access

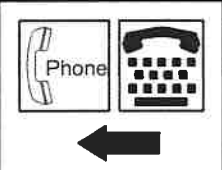
<p>4.13 Does at least one telephone have a volume control? [704.3]</p>	<p><input type="checkbox"/> Yes <input type="checkbox"/> No</p> <p>N/A</p>		<p>Photo #:</p>	<ul style="list-style-type: none"> • Install volume control • Replace telephone with one that has volume control •
<p>4.14 Is the volume control identified by a pictogram of a telephone handset with radiating sound waves? [703.7.2.3]</p>	<p><input type="checkbox"/> Yes <input type="checkbox"/> No</p> <p>N/A</p>		<p>Photo #:</p>	<ul style="list-style-type: none"> • Add pictogram • •
<p>4.15 Does at least one telephone have a TTY? [217.4.1]</p> <p>Note: TTY's are devices that employ interactive text-based communication through the transmission of coded signals across the telephone network. They are mainly used by people who are deaf and/or cannot speak.</p>	<p><input type="checkbox"/> Yes <input type="checkbox"/> No</p> <p>N/A</p>		<p>Photo #:</p>	<ul style="list-style-type: none"> • Install TTY • •
<p>4.16 Is the touch surface of the TTY keypad at least 34 inches above the floor? [704.4.1]</p> <p>Note: If a seat is provided, the TTY is not required to be 34 inches minimum above the floor.</p>	<p><input type="checkbox"/> Yes <input type="checkbox"/> No</p> <p>Measurement:</p> <p>N/A</p>		<p>Photo #:</p>	<ul style="list-style-type: none"> • Adjust height of TTY • •

<p>4.17 Is the TTY identified by the International Symbol of TTY? [703.7.2.2]</p>	<p><input type="checkbox"/> Yes <input type="checkbox"/> No</p> <p>N/A</p>		<p>Photo #:</p>	<ul style="list-style-type: none"> • Add symbol • •
<p>4.18 Do signs that provide direction to public telephones also provide direction to the TTY? [216.9.2]</p>	<p><input type="checkbox"/> Yes <input type="checkbox"/> No</p> <p>N/A</p>		<p>Photo #:</p>	<ul style="list-style-type: none"> • Add signs • •
<p>4.19 Do telephones that do not have a TTY provide direction to the TTY? [216.9.2]</p>	<p><input type="checkbox"/> Yes <input type="checkbox"/> No</p> <p>N/A</p>		<p>Photo #:</p>	<ul style="list-style-type: none"> • Add signs • •
<p>Fire Alarm Systems</p>				
<p>4.20 If there are fire alarm systems, do they have both flashing lights and audible signals? [702.1]</p>	<p><input type="checkbox"/> Yes <input checked="" type="checkbox"/> No</p> <p>NO VISUAL</p>		<p>Photo #:</p>	<ul style="list-style-type: none"> • Install audible and visual alarms • •



TOWN OF WEAVERVILLE

APPENDIX C.4:

Water Treatment Plant

ADA TRANSITION PLAN

ADA Checklist for Existing Facilities

Priority 1 – Approach & Entrance

Based on the 2010 ADA Standards for Accessible Design



Project ADA TRANSITION PLANE

Building WATER TREATMENT PLANT

Location WEAVERVILLE H.C.

Date 4-21-2020

Surveyors ALAN F. MACKAY

Contact Information TRENT DUNCAN

An accessible route from site arrival points and an accessible entrance should be provided for everyone.



Institute for Human Centered Design
www.HumanCenteredDesign.org
Copyright © 2016



ADA National Network
Questions on the ADA 800-949-4232 voice/tty
www.ADAchecklist.org

This checklist was produced by the New England ADA Center, a project of the Institute for Human Centered Design and a member of the ADA National Network. This checklist was developed under a grant from the Department of Education, NIDRR grant number H133A060092-09A. However the contents do not necessarily represent the policy of the Department of Education, and you should not assume endorsement by the Federal Government.

Questions or comments on the checklist contact the New England ADA Center at 617-695-0085 voice/tty or ADAinfo@NewEnglandADA.org



For the full set of checklists, including the checklists for recreation facilities visit www.ADAchecklist.org.

Copyright © 2016 ADA Checklist for Existing Materials. You can freely reproduce and distribute this content. Include proper attribution. But you must get permission before using this content as a fee-based product.

Priority 1 – Approach & Entrance		Comments	Possible Solutions												
<p>1.1 Is there at least one route from site arrival points (parking, passenger loading zones, public sidewalks and public transportation stops) that does not require the use of stairs? [See 2010 ADA Standards for Accessible Design – 206.2.1]</p>	<p><input checked="" type="checkbox"/> Yes <input type="checkbox"/> No</p> <p>If yes, location of route: PARKING LOT</p>	<p>Photo #:</p>	<ul style="list-style-type: none"> • Add a ramp • Regrade to 1:20 maximum slope • Add a lift if site constraints prevent other solutions 												
<p>Parking Accessible parking spaces should be identified by size, access aisle and signage.</p>															
<p>1.2 If parking is provided for the public, are an adequate number of accessible spaces provided? [208.2]</p>	<p><input type="checkbox"/> Yes <input type="checkbox"/> No</p> <p>Total #: N/A Accessible #: N/A</p>	<table border="1"> <thead> <tr> <th>Total Spaces</th> <th>Accessible Spaces</th> </tr> </thead> <tbody> <tr> <td>1 - 25</td> <td>1</td> </tr> <tr> <td>26 - 50</td> <td>2</td> </tr> <tr> <td>51 - 75</td> <td>3</td> </tr> <tr> <td>76 - 100</td> <td>4</td> </tr> <tr> <td colspan="2">100+ see 2010 Standards 208.2</td> </tr> </tbody> </table> <p>Photo #:</p>	Total Spaces	Accessible Spaces	1 - 25	1	26 - 50	2	51 - 75	3	76 - 100	4	100+ see 2010 Standards 208.2		<ul style="list-style-type: none"> • Reconfigure by repainting lines • •
Total Spaces	Accessible Spaces														
1 - 25	1														
26 - 50	2														
51 - 75	3														
76 - 100	4														
100+ see 2010 Standards 208.2															
<p>1.3 Of the accessible spaces, is at least one a van accessible space?*[208.2.4]</p>	<p><input type="checkbox"/> Yes <input checked="" type="checkbox"/> No</p> <p>NA</p>	<p>*For every 6 or fraction of 6 parking spaces required by the table above, at least 1 should be a van accessible space.</p> <p>Photo #:</p>	<ul style="list-style-type: none"> • If constructed before 3/15/2012, parking is compliant if at least 1 in every 8 accessible spaces is van accessible • Reconfigure by repainting lines 												

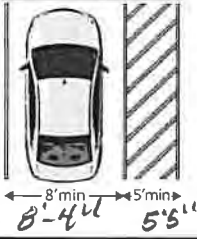
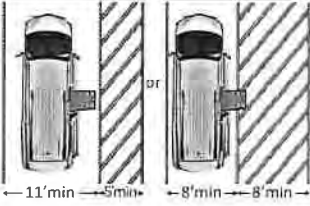

ADA Checklist for Existing Facilities



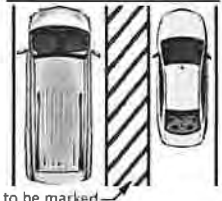

Priority 1 – Approach & Entrance

<p>1.4 Are accessible spaces at least 8 feet wide with an access aisle at least 5 feet wide? [502.2, 502.3]</p> <p>Note: Two spaces may share an access aisle. Check state/local requirements; some specify that each space have its own aisle.</p>	<p><input checked="" type="checkbox"/> Yes <input type="checkbox"/> No</p> <p>Measurement: 8'-4" WIDE 5'-5" WIDE</p>	 <p>8' min 5' min 8'-4" 5'-5"</p>	<p>Photo #:</p>	<ul style="list-style-type: none"> • Reconfigure by repainting lines • •
<p>1.5 Is the van accessible space:</p> <p>At least 11 feet wide with an access aisle at least 5 feet wide? Or At least 8 feet wide with an access aisle at least 8 feet wide? [502.2]</p>	<p><input type="checkbox"/> Yes <input type="checkbox"/> No</p> <p>Measurement: NA</p> <p><input type="checkbox"/> Yes <input type="checkbox"/> No</p> <p>Measurement: NA</p>	 <p>11' min 5' min 8' min 8' min</p>	<p>Photo #:</p>	<ul style="list-style-type: none"> • Reconfigure to provide van-accessible space(s) • •
<p>1.6 Is at least 98 inches of vertical clearance provided for the van accessible space? [502.5]</p>	<p><input type="checkbox"/> Yes <input type="checkbox"/> No</p> <p>Measurement: NA</p>	 <p>98" min</p>	<p>Photo #:</p>	<ul style="list-style-type: none"> • Reconfigure to provide van-accessible space(s) • •

ADA Checklist for Existing Facilities

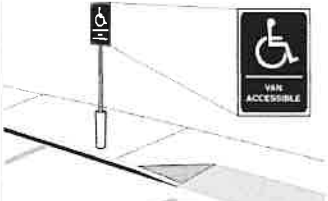
Priority 1 – Approach & Entrance



<p>1.7 Are the access aisles marked so as to discourage parking in them? [502.3.3]</p> <p>Note: The marking method and color may be addressed by state/local requirements.</p>	<p><input checked="" type="checkbox"/> Yes <input type="checkbox"/> No</p>		<p>Photo #:</p>	<ul style="list-style-type: none"> • Mark access aisles
<p>1.8 Is the slope of the accessible parking spaces and access aisles no steeper than 1:48 in all directions? [502.4]</p>	<p><input checked="" type="checkbox"/> Yes <input type="checkbox"/> No</p> <p>Measurement: 1:12</p>		<p>Photo #:</p>	<ul style="list-style-type: none"> • Regrade surface
<p>1.9 Do the access aisles adjoin an accessible route? [502.3]</p>	<p><input type="checkbox"/> Yes <input checked="" type="checkbox"/> No</p> <p>NO HANDICAP RAMPS OR ACCESS</p>		<p>Photo #:</p>	<ul style="list-style-type: none"> • Create accessible route • Relocate accessible space
<p>1.10 Are accessible spaces identified with a sign that includes the International Symbol of Accessibility? Is the bottom of the sign at least 60 inches above the ground? [502.6]</p> <p>Note: The International Symbol of Accessibility is not required on the ground.</p>	<p><input checked="" type="checkbox"/> Yes <input type="checkbox"/> No</p> <p><input type="checkbox"/> Yes <input checked="" type="checkbox"/> No</p> <p>Measurement: 6'-5"</p>		<p>Photo #:</p>	<ul style="list-style-type: none"> • Install signs

<p>1.11 Are there signs reading “van accessible” at van accessible spaces? [502.6]</p>	<p><input type="checkbox"/> Yes <input checked="" type="checkbox"/> No</p>	 <p>The diagram shows a parking space with a sign on a post that reads "VAN ACCESSIBLE" and features the wheelchair symbol. A van is shown parked in the space.</p>	<p>Photo #:</p>	<ul style="list-style-type: none"> • Install signs • •
<p>1.12 Of the total parking spaces, are the accessible spaces located on the closest accessible route to the accessible entrance(s)? [208.3.1]</p> <p>Note: If parking serves multiple entrances, accessible parking should be dispersed.</p>	<p><input type="checkbox"/> Yes <input type="checkbox"/> No</p> <p>NA</p>		<p>Photo #:</p>	<ul style="list-style-type: none"> • Reconfigure spaces • •
<p>Exterior Accessible Route</p>				
<p>1.13 Is the route stable, firm and slip-resistant? [302.1]</p>	<p><input type="checkbox"/> Yes <input type="checkbox"/> No</p> <p>NA</p>		<p>Photo #:</p>	<ul style="list-style-type: none"> • Repair uneven paving • Fill small bumps and breaks with patches • Replace gravel with asphalt or other surface
<p>1.14 Is the route at least 36 inches wide? [403.5.1]</p>	<p><input type="checkbox"/> Yes <input type="checkbox"/> No</p> <p>Measurement:</p> <p>NA</p>	 <p>The diagram shows a cross-section of a path with a double line indicating a width. A vertical double-headed arrow on the left is labeled "36' min". A person is walking on the path.</p>	<p>Photo #:</p>	<ul style="list-style-type: none"> • Change or move landscaping, furnishings or other items • Widen route •

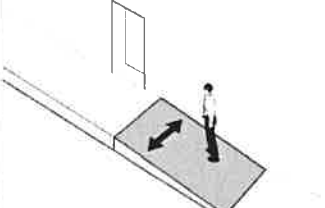
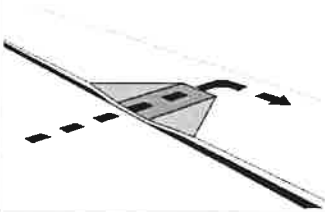
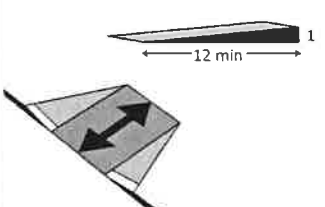
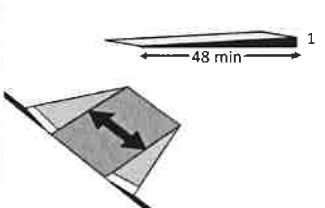
<p>Note: The accessible route can narrow to 32 inches min. for a max. of 24 inches. These narrower portions of the route must be at least 48 inches from each other.</p>			<p>Photo #:</p>	
<p>1.15 If the route is greater than 200 feet in length and less than 60 inches wide, is there a passing space no less than 60 x 60 inches? [403.5.3]</p>	<p><input type="checkbox"/> Yes <input type="checkbox"/> No Measurement: NA</p>		<p>Photo #:</p>	<ul style="list-style-type: none"> • Widen route for passing space • •
<p>1.16 If there are grates or openings on the route, are the openings no larger than 1/2 inches? [302.3]</p> <p>Is the long dimension perpendicular to the dominant direction of travel?</p>	<p><input type="checkbox"/> Yes <input type="checkbox"/> No Measurement: NA <input type="checkbox"/> Yes <input type="checkbox"/> No NA</p>		<p>Photo #:</p>	<ul style="list-style-type: none"> • Replace or move grate • •
<p>1.17 Is the running slope no steeper than 1:20, i.e. for every inch of height change there are at least 20 inches of route run? [403.3]</p> <p>Note: If the running slope is steeper than 1:20, treat as a ramp and add features such as edge protection and handrails.</p>	<p><input type="checkbox"/> Yes <input type="checkbox"/> No Measurement: NA</p>		<p>Photo #:</p>	<ul style="list-style-type: none"> • Regrade to 1:20 max. • •

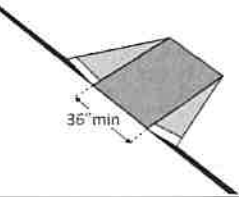
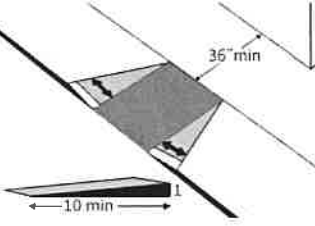
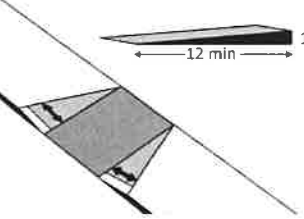
<p>1.18 Is the cross slope no steeper than 1:48? [403.3]</p>	<p><input type="checkbox"/> Yes <input type="checkbox"/> No</p> <p>Measurement: <i>NA</i></p>		<p>Photo #:</p>	<ul style="list-style-type: none"> • Regrade to 1:48 max. • •
Curb Ramps				
<p>1.19 If the accessible route crosses a curb, is there a curb ramp? [402.2]</p>	<p><input type="checkbox"/> Yes <input type="checkbox"/> No</p> <p><i>NA</i></p>		<p>Photo #:</p>	<ul style="list-style-type: none"> • Install curb ramp • •
<p>1.20 Is the running slope of the curb ramp no steeper than 1:12, i.e. for every inch of height change there are at least 12 inches of curb ramp run? [406.1, 405.2]</p>	<p><input type="checkbox"/> Yes <input type="checkbox"/> No</p> <p>Measurement: <i>NA</i></p>		<p>Photo #:</p>	<ul style="list-style-type: none"> • Regrade curb ramp • •
<p>1.21 Is the cross slope of the curb ramp, excluding flares, no steeper than 1:48? [406.1, 405.3]</p>	<p><input type="checkbox"/> Yes <input type="checkbox"/> No</p> <p>Measurement: <i>NA</i></p>		<p>Photo #:</p>	<ul style="list-style-type: none"> • Regrade curb ramp • •

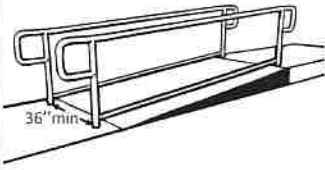

<p>1.22 Is the curb ramp, excluding flares, at least 36 inches wide? [406.1, 405.5]</p>	<p><input type="checkbox"/> Yes <input type="checkbox"/> No Measurement: NA</p>		<p>Photo #:</p>	<ul style="list-style-type: none"> • Widen curb ramp • •
<p>1.23 At the top of the curb ramp is there a level landing (slope no steeper than 1:48 in all directions) that is at least 36 inches long and at least as wide as the curb ramp? [406.4]</p> <p>If there are curb ramp flares, are the slopes of the flares no steeper than 1:10, i.e. for every inch of height change there are at least 10 inches of flare run? [406.3]</p>	<p><input type="checkbox"/> Yes <input type="checkbox"/> No Measurement: NA</p> <p><input type="checkbox"/> Yes <input type="checkbox"/> No Measurement: NA</p>		<p>Photo #:</p>	<ul style="list-style-type: none"> • Reconfigure • Add ramp flares •
<p>1.24 If the landing at the top is less than 36 inches long, are there curb ramp flares?</p> <p>Are the slopes of the flares no greater than 1:12, i.e. for every inch of height change there are at least 12 inches of flare run? [406.4]</p>	<p><input type="checkbox"/> Yes <input type="checkbox"/> No NA</p> <p><input type="checkbox"/> Yes <input type="checkbox"/> No Measurement: NA</p>		<p>Photo #:</p>	<ul style="list-style-type: none"> • Add ramp flares • Regrade flares •

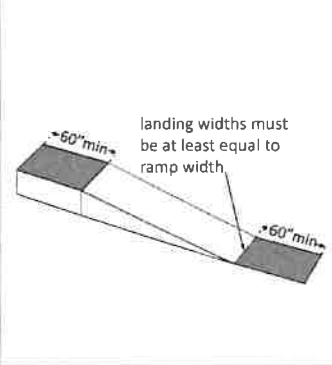
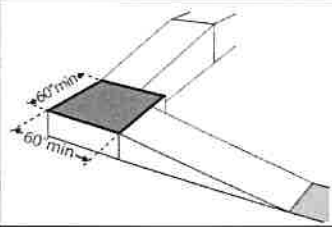
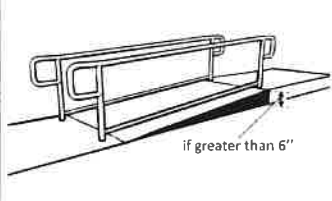
Ramps If any portion of the accessible route is steeper than 1:20, it should be treated as a ramp.				
<p>1.25 If there is a ramp is it at least 36 inches wide? [405.5]</p> <p>Note: If there are handrails, measure between the handrails.</p>	<p><input type="checkbox"/> Yes <input type="checkbox"/> No</p> <p>Measurement: NA</p>		<p>Photo #:</p>	<ul style="list-style-type: none"> • Alter ramp • •
<p>1.26 Is the surface stable, firm and slip resistant? [405.4]</p>	<p><input type="checkbox"/> Yes <input type="checkbox"/> No</p> <p>NA</p>		<p>Photo #:</p>	<ul style="list-style-type: none"> • Resurface ramp • •
<p>1.27 For each section of the ramp, is the running slope no greater than 1:12, i.e. for every inch of height change there are at least 12 inches of ramp run? [405.2]</p> <p>Note: Rises no greater than 3 inches with a slope no steeper than 1:8 and rises no greater than 6 inches with a slope no steeper than 1:10 are permitted when such slopes are necessary due to space limitations.</p>	<p><input type="checkbox"/> Yes <input type="checkbox"/> No</p> <p>Measurement: NA</p>		<p>Photo #:</p>	<ul style="list-style-type: none"> • Relocate ramp • Lengthen ramp to decrease slope •

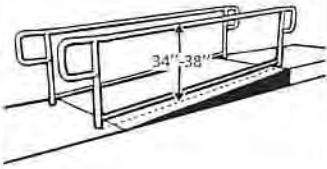
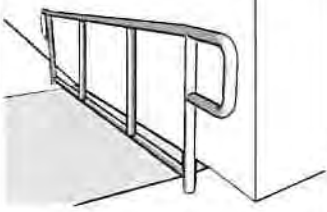
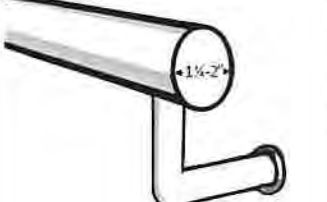
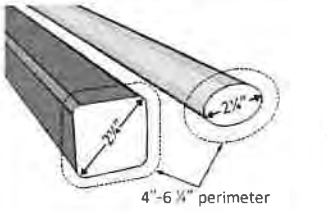

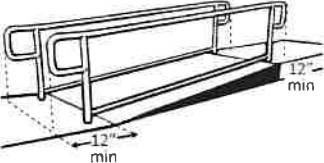
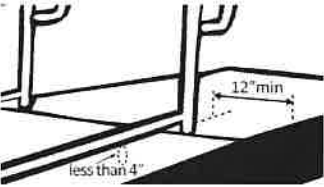
<p>1.28 Is there a level landing that is at least 60 inches long and at least as wide as the ramp:</p> <p>At the top of the ramp?</p> <p>At the bottom of the ramp? [405.7.2, 405.7.3]</p>	<p><input type="checkbox"/> Yes <input type="checkbox"/> No</p> <p>Measurement: NA</p> <p><input type="checkbox"/> Yes <input type="checkbox"/> No</p> <p>Measurement: NA</p>		<p>Photo #:</p>	<ul style="list-style-type: none"> • Alter ramp • Relocate ramp •
<p>1.29 Is there a level landing where the ramp changes direction that is at least 60 x 60 inches? [405.7.4]</p>	<p><input type="checkbox"/> Yes <input type="checkbox"/> No</p> <p>Measurement: NA</p>		<p>Photo #:</p>	<ul style="list-style-type: none"> • Alter ramp • Increase landing size •
<p>1.30 If the ramp has a rise higher than 6 inches, are there handrails on both sides? [405.8]</p> <p>Note: Curb ramps are not required to have handrails.</p>	<p><input type="checkbox"/> Yes <input type="checkbox"/> No</p> <p>Measurement: NA</p>		<p>Photo #:</p>	<ul style="list-style-type: none"> • Add handrails • •

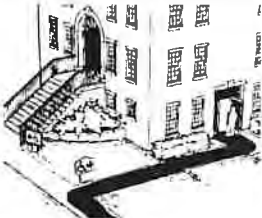
<p>1.31 Is the top of the handrail gripping surface no less than 34 inches and no greater than 38 inches above the ramp surface? [505.4]</p>	<p><input type="checkbox"/> Yes <input type="checkbox"/> No Measurement: NA</p>		<p>Photo #:</p>	<ul style="list-style-type: none"> • Reconfigure or replace handrails • Adjust handrail height
<p>1.32 Is the handrail gripping surface continuous and not obstructed along the top or sides? [505.3]</p> <p>If there are obstructions, is the bottom of the gripping surface obstructed no greater than 20%? [505.6]</p>	<p><input type="checkbox"/> Yes <input type="checkbox"/> No NA</p> <p><input type="checkbox"/> Yes <input type="checkbox"/> No Measurement: NA</p>		<p>Photo #:</p>	<ul style="list-style-type: none"> • Reconfigure or replace handrails
<p>1.33 If the handrail gripping surface is circular, is it no less than 1 1/4 inches and no greater than 2 inches in diameter? [505.7.1]</p>	<p><input type="checkbox"/> Yes <input type="checkbox"/> No Measurement: NA</p>		<p>Photo #:</p>	<ul style="list-style-type: none"> • Replace handrails
<p>1.34 If the handrail gripping surface is non-circular:</p> <p>Is the perimeter no less than 4 inches and no greater than 6 1/4 inches?</p>	<p><input type="checkbox"/> Yes <input type="checkbox"/> No Measurement: NA</p> <p><input type="checkbox"/> Yes <input type="checkbox"/> No Measurement: NA</p>		<p>Photo #:</p>	<ul style="list-style-type: none"> • Replace handrails

<p>Is the cross section no greater than 2¼ inches? [505.7.2]</p>	<p><input type="checkbox"/> Yes <input type="checkbox"/> No Measurement: NA</p>		<p>Photo #:</p>	
<p>1.35 Does the handrail:</p> <p>Extend at least 12 inches horizontally beyond the top and bottom of the ramp?</p> <p>Return to a wall, guard, or landing surface? [505.10.1]</p> <p>Note: If a 12 inch extension would be a hazard (in circulation path) it is not required.</p>	<p><input type="checkbox"/> Yes <input type="checkbox"/> No Measurement: NA</p> <p><input type="checkbox"/> Yes <input type="checkbox"/> No NA</p>		<p>Photo #:</p>	<ul style="list-style-type: none"> • Alter handrails • •
<p>1.36 To prevent wheelchair casters and crutch tips from falling off:</p> <p>Does the surface of the ramp extend at least 12 inches beyond the inside face of the handrail? Or Is there a curb or barrier that prevents the passage of a 4-inch diameter sphere? [405.9.1, 405.9.2]</p>	<p><input type="checkbox"/> Yes <input type="checkbox"/> No Measurement: NA</p> <p><input type="checkbox"/> Yes <input type="checkbox"/> No Measurement: NA</p>		<p>Photo #:</p>	<ul style="list-style-type: none"> • Add curb • Add barrier • Extend ramp width •

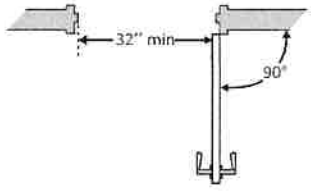
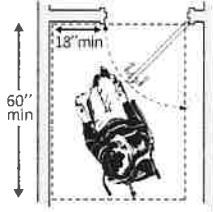
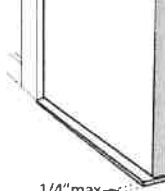
Entrance				
<p>1.37 Is the main entrance accessible?</p>	<input type="checkbox"/> Yes <input type="checkbox"/> No <p>NA</p>		<p>Photo #:</p>	<ul style="list-style-type: none"> • Redesign to make it accessible • •
<p>1.38 If the main entrance is not accessible, is there an alternative accessible entrance? Can the alternative accessible entrance be used independently and during the same hours as the main entrance?</p>	<input type="checkbox"/> Yes <input type="checkbox"/> No <p>NA</p> <input type="checkbox"/> Yes <input type="checkbox"/> No <p>NA</p>		<p>Photo #:</p>	<ul style="list-style-type: none"> • Designate an entrance and make it accessible • Ensure that accessible entrance can be used independently and during the same hours as the main entrance •
<p>1.39 Do all inaccessible entrances have signs indicating the location of the nearest accessible entrance? [216.6]</p>	<input type="checkbox"/> Yes <input type="checkbox"/> No <p>NA</p>		<p>Photo #:</p>	<ul style="list-style-type: none"> • Install signs • Install signs on route before people get to inaccessible entrances so that people do not have to turn around and retrace route •
<p>1.40 If not all entrances are accessible, is there a sign at the accessible entrance with the International Symbol of Accessibility? [216.6]</p>	<input type="checkbox"/> Yes <input type="checkbox"/> No <p>NA</p>		<p>Photo #:</p>	<ul style="list-style-type: none"> • Install sign • •

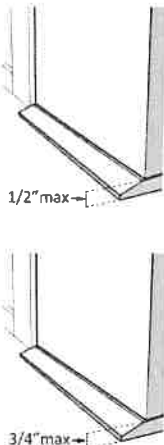
<p>1.41 Is the clear opening width of the accessible entrance door at least 32 inches, between the face of the door and the stop, when the door is open 90 degrees? [404.2.3]</p>	<p><input type="checkbox"/> Yes <input type="checkbox"/> No Measurement: NA</p>		<p>Photo #:</p>	<ul style="list-style-type: none"> • Alter door • Install offset hinges •
<p>1.42 If there is a front approach to the pull side of the door, is there at least 18 inches of maneuvering clearance beyond the latch side plus at least 60 inches clear depth? Note: See 2010 Standards 404.2.4 for maneuvering clearance requirements on the push side of the door and side approaches to the pull side of the door</p> <p>On both sides of the door, is the ground or floor surface of the maneuvering clearance level (no steeper than 1:48)? [404.2.4]</p>	<p><input type="checkbox"/> Yes <input type="checkbox"/> No Measurement: NA</p> <p><input type="checkbox"/> Yes <input type="checkbox"/> No Measurement: NA</p>		<p>Photo #:</p>	<ul style="list-style-type: none"> • Remove obstructions • Reconfigure walls • Add automatic door opener
<p>1.43 If the threshold is vertical is it no more than ¼ inch high? Or No more than ¼ inch high with the top ¼ inch beveled no steeper than 1:2, if the threshold was installed on or</p>	<p><input type="checkbox"/> Yes <input type="checkbox"/> No Measurement: NA</p> <p><input type="checkbox"/> Yes <input type="checkbox"/> No Measurement: NA</p>		<p>Photo #:</p>	<ul style="list-style-type: none"> • Remove or replace threshold • •

<p>after the 1991 ADA Standards went into effect (1/26/93)?</p> <p>Or</p> <p>No more than 3/4 inch high with the top 1/2 inch beveled no steeper than 1:2, if the threshold was installed before the 1991 ADA Standards went into effect (1/26/93)? [404.2.5, 303.2]</p> <p>Note: The first 1/4 inch of the 1/2 or 3/4 inch threshold may be vertical; the rest must be beveled.</p>	<p><input type="checkbox"/> Yes <input type="checkbox"/> No</p> <p>Measurement:</p> <p>NA</p>		<p>Photo #:</p>	
<p>1.44 Is the door equipped with hardware that is operable with one hand and does not require tight grasping, pinching or twisting of the wrist?</p> <p>Door handle?</p> <p>Lock (if provided)? [404.2.7]</p>	<p><input type="checkbox"/> Yes <input type="checkbox"/> No</p> <p>NA</p> <p><input type="checkbox"/> Yes <input type="checkbox"/> No</p> <p>NA</p> <p><input type="checkbox"/> Yes <input type="checkbox"/> No</p> <p>NA</p>		<p>Photo #:</p>	<ul style="list-style-type: none"> • Replace inaccessible knob with lever, loop or push hardware • Add automatic door opener

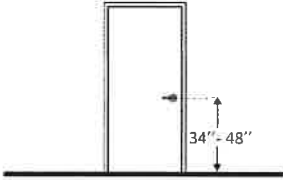
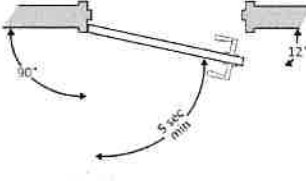
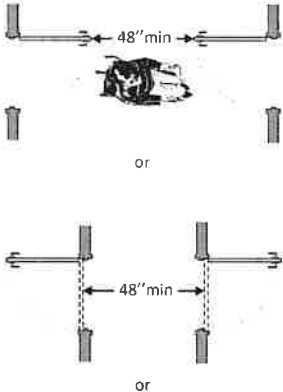
<p>1.45 Are the operable parts of the door hardware no less than 34 inches and no greater than 48 inches above the floor or ground surface? [404.2.7]</p>	<p><input type="checkbox"/> Yes <input type="checkbox"/> No Measurement: NA</p>		<p>Photo #:</p>	<ul style="list-style-type: none"> • Change hardware height • •
<p>1.46 If the door has a closer, does it take at least 5 seconds to close from an open position of 90 degrees to a position of 12 degrees from the latch? [404.2.8]</p>	<p><input type="checkbox"/> Yes <input type="checkbox"/> No Measurement: NA</p>		<p>Photo #:</p>	<ul style="list-style-type: none"> • Adjust closer • •
<p>1.47 If there are two doors in a series, e.g. vestibule, is the distance between the doors at least 48 inches plus the width of the doors when swinging into the space? [404.2.6]</p>	<p><input type="checkbox"/> Yes <input type="checkbox"/> No Measurement: NA</p>		<p>Photo #:</p>	<ul style="list-style-type: none"> • Remove inner door • Change door swing •

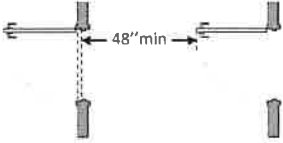
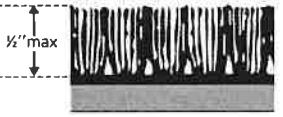
			Photo #:	
<p>1.48 If provided at the building entrance, are carpets or mats no higher than ½ inch thick? [302.2]</p>	<p><input type="checkbox"/> Yes <input type="checkbox"/> No</p> <p>Measurement: NA</p>		Photo #:	<ul style="list-style-type: none"> • Replace or remove mats • •
<p>1.49 Are edges of carpets or mats securely attached to minimize tripping hazards? [302.2]</p>	<p><input type="checkbox"/> Yes <input type="checkbox"/> No</p> <p>NA</p>		Photo #:	<ul style="list-style-type: none"> • Secure carpeting or mats at edges • •
	<p><input type="checkbox"/> Yes <input type="checkbox"/> No</p>		Photo #:	<ul style="list-style-type: none"> • • •
	<p><input type="checkbox"/> Yes <input type="checkbox"/> No</p>		Photo #:	<ul style="list-style-type: none"> • • •

ADA Checklist for Existing Facilities

Priority 2 – Access to Goods & Services

Based on the 2010 ADA Standards for Accessible Design

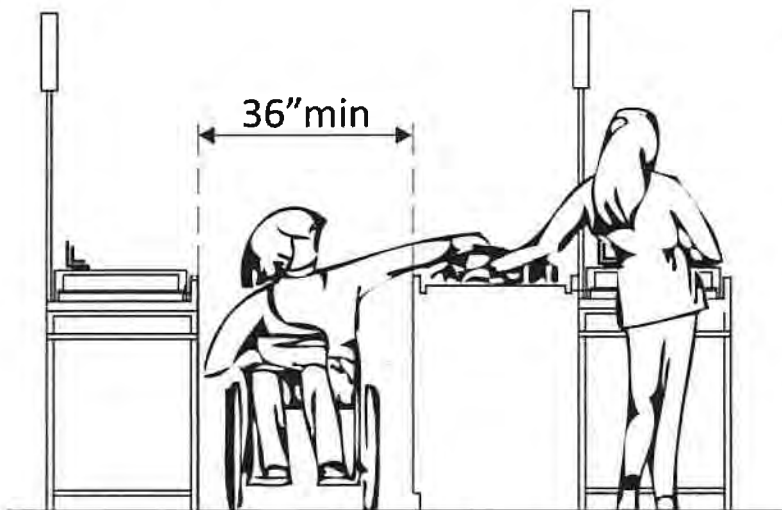

Project ADA TRANSITION PLAN

Building WATER TREATMENT PLANT

Location WEAVERVILLE N.C.

Date 4-21-2020

Surveyors ASHAN F. MACKAY

Contact Information TRENT DUNCAN

The layout of the building should allow people with disabilities to obtain goods and services and to participate in activities without assistance.



Institute for Human Centered Design
www.HumanCenteredDesign.org
Copyright © 2016



ADA National Network
Questions on the ADA 800-949-4232 voice/tty
www.ADAchecklist.org

This checklist was produced by the New England ADA Center, a project of the Institute for Human Centered Design and a member of the ADA National Network. This checklist was developed under a grant from the Department of Education, NIDRR grant number H133A060092-09A. However the contents do not necessarily represent the policy of the Department of Education, and you should not assume endorsement by the Federal Government.

Questions or comments on the checklist contact the New England ADA Center at 617-695-0085 voice/tty or ADAinfo@NewEnglandADA.org

For the full set of checklists, including the checklists for recreation facilities visit www.ADAchecklist.org.

Copyright © 2016 ADA Checklist for Existing Materials. You can freely reproduce and distribute this content. Include proper attribution. But you must get permission before using this content as a fee-based product.

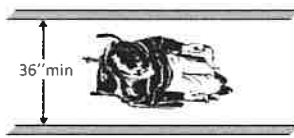
Priority 2 – Access to Goods & Services		Comments	Possible Solutions
<p>2.1 Does the accessible entrance provide direct access to the main floor, lobby and elevator? [See 2010 ADA Standards for Accessible Design – 206.4]</p>	<p><input type="checkbox"/> Yes <input type="checkbox"/> No</p> <p>NA</p>	<p>Photo #:</p>	<ul style="list-style-type: none"> • Create accessible route • •
<p>Interior Accessible Route</p>			
<p>2.2 Are all public spaces on at least one accessible route? [206.2.4]</p>	<p><input type="checkbox"/> Yes <input type="checkbox"/> No</p> <p>NA</p>	<p>Photo #:</p>	<ul style="list-style-type: none"> • Create accessible route • •
<p>2.3 Is the route stable, firm and slip-resistant? [40.2, 302.1]</p>	<p><input type="checkbox"/> Yes <input type="checkbox"/> No</p> <p>NA</p>	<p>Photo #:</p>	<ul style="list-style-type: none"> • Repair uneven surfaces • •
<p>2.4 Is the route at least 36 inches wide? [403.5.1]</p> <p>Note: The accessible route can narrow to 32 inches min. for a max. of 24 inches. These narrower portions of the route must be at least 48 inches from each other.</p>	<p><input type="checkbox"/> Yes <input type="checkbox"/> No</p> <p>Measurement:</p> <p>NA</p>		<ul style="list-style-type: none"> • Widen route • •

			<p>Photo #:</p>	
<p>2.5 If the route is greater than 200 feet in length and less than 60 inches wide, is there a passing space no less than 60 x 60 inches? [403.5.3]</p>	<p><input type="checkbox"/> Yes <input type="checkbox"/> No</p> <p>Measurement: NA</p>		<p>Photo #:</p>	<ul style="list-style-type: none"> • Widen route for passing space • •
<p>2.6 Is the running slope no steeper than 1:20, i.e. for every inch of height change there are at least 20 inches of route run? [403.3]</p> <p>Note: If the running slope is steeper than 1:20, treat as a ramp and add features such as edge protection and handrails.</p>	<p><input type="checkbox"/> Yes <input type="checkbox"/> No</p> <p>Measurement: NA</p>		<p>Photo #:</p>	<ul style="list-style-type: none"> • Regrade • •
<p>2.7 Is the cross slope no steeper than 1:48? [403.3]</p>	<p><input type="checkbox"/> Yes <input type="checkbox"/> No</p> <p>Measurement: NA</p>		<p>Photo #:</p>	<ul style="list-style-type: none"> • Regrade • •

2.8 Do all objects on circulation paths through public areas, e.g. fire extinguishers, drinking fountains, signs, etc., protrude no more than 4 inches into the path?

Yes No

Measurement:

NA



Or

Or

If an object protrudes more than 4 inches, is the bottom leading edge at 27 inches or lower above the floor? [307.2]

Yes No

Measurement:

NA

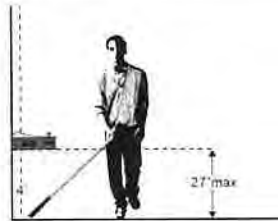

Or

Or

Is the bottom leading edge at 80 inches or higher above the floor? [307.4]

Yes No

Measurement:

NA

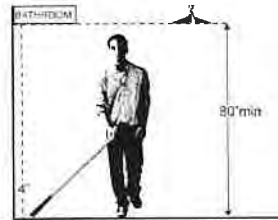

Photo #:

- Remove object
- Add tactile warning such as permanent planter or partial walls
-

2.9 Are there elevators or platform lifts to all public stories?

Yes No

Note: Vertical access is not required in new construction or alterations if a facility is less than three stories or has less than 3,000 square feet per story, unless the facility is a shopping center, shopping mall,

NA

- Install if necessary
- Offer goods and services on an accessible story
-

professional office of a health care provider, transportation terminal, state facility or local government facility

Photo #:

Ramps

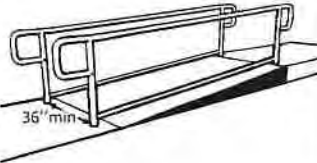
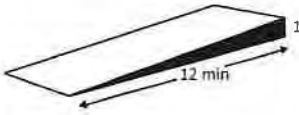
<p>2.10 If there is a ramp, is it at least 36 inches wide? [405.5]</p> <p>Note: If there are handrails, measure between the handrails.</p>	<p><input type="checkbox"/> Yes <input type="checkbox"/> No</p> <p>Measurement:</p> <p>NA</p>		<p>Photo #:</p>	<ul style="list-style-type: none"> • Alter ramp • •
<p>2.11 Is the surface stable, firm and slip resistant? [405.4]</p>	<p><input type="checkbox"/> Yes <input type="checkbox"/> No</p> <p>NA</p>		<p>Photo #:</p>	<ul style="list-style-type: none"> • Resurface ramp • •
<p>2.12 For each section of the ramp, is the running slope no greater than 1:12, i.e. for every inch of height change there are at least 12 inches of ramp run? [405.2]</p> <p>Note: Rises no greater than 3 inches with a slope no steeper than 1:8 and rises no greater</p>	<p><input type="checkbox"/> Yes <input type="checkbox"/> No</p> <p>Measurement:</p> <p>NA</p>		<p>Photo #:</p>	<ul style="list-style-type: none"> • Lengthen ramp to decrease slope • Relocate ramp •

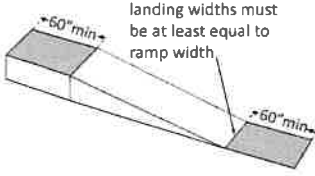
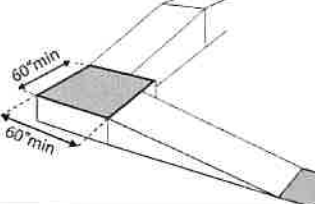
<p>than 6 inches with a slope no steeper than 1:10 are permitted when due to space limitations.</p>			<p>Photo #:</p>	
<p>2.13 Is there a level landing that is at least 60 inches long and at least as wide as the ramp:</p> <p>At the top of the ramp?</p> <p><input type="checkbox"/> Yes <input type="checkbox"/> No</p> <p>Measurement: NA</p> <p>At the bottom of the ramp? [405.7.2, 405.7.3]</p> <p><input type="checkbox"/> Yes <input type="checkbox"/> No</p> <p>Measurement: NA</p>			<p>Photo #:</p>	<ul style="list-style-type: none"> • Alter ramp • Relocate ramp •
<p>2.14 Is there a level landing where the ramp changes direction that is at least 60 x 60 inches? [405.7.4]</p> <p><input type="checkbox"/> Yes <input type="checkbox"/> No</p> <p>Measurement: NA</p>			<p>Photo #:</p>	<ul style="list-style-type: none"> • Increase landing size • •

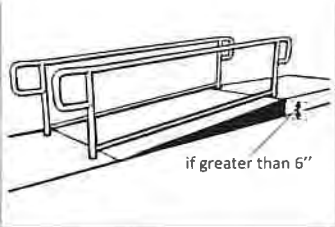
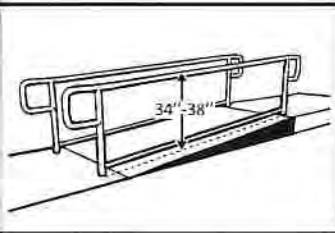
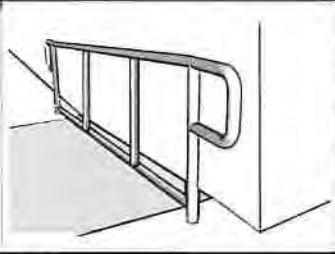
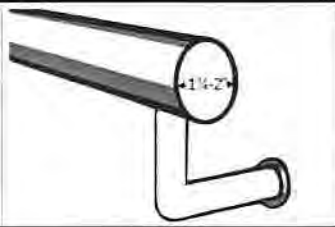
<p>2.15 If the ramp has a rise higher than 6 inches are there handrails on both sides? [405.8]</p>	<p><input type="checkbox"/> Yes <input type="checkbox"/> No Measurement: <i>NA</i></p>		<p>Photo #:</p> <ul style="list-style-type: none"> • Add handrails • •
<p>2.16 Is the top of the handrail gripping surface no less than 34 inches and no greater than 38 inches above the ramp surface? [505.4]</p>	<p><input type="checkbox"/> Yes <input type="checkbox"/> No Measurement: <i>NA</i></p>		<p>Photo #:</p> <ul style="list-style-type: none"> • Adjust handrail height • •
<p>2.17 Is the handrail gripping surface continuous and not obstructed along the top or sides? [505.3]</p> <p>If there are obstructions, is the bottom of the gripping surface obstructed no more than 20%? [505.6]</p>	<p><input type="checkbox"/> Yes <input type="checkbox"/> No <i>NA</i> <input type="checkbox"/> Yes <input type="checkbox"/> No Measurement: <i>NA</i></p>		<p>Photo #:</p> <ul style="list-style-type: none"> • Reconfigure or replace handrails • •
<p>2.18 If the handrail gripping surface is circular, is it no less than 1 1/4 inches and no greater than 2 inches in diameter? [505.7.1]</p>	<p><input type="checkbox"/> Yes <input type="checkbox"/> No Measurement: <i>NA</i></p>		<p>Photo #:</p> <ul style="list-style-type: none"> • Replace handrails • •

2.19 If the handrail gripping surface is non-circular:

Is the perimeter no less than 4 inches and no greater than 6 1/2 inches?

Yes No

Measurement:

N/A

Is the cross section no greater than 2 1/4 inches in diameter? [505.7.2]

Yes No

Measurement:

N/A

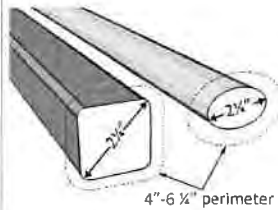

Photo #:

- Replace handrails
-
-

2.20 Does the handrail:

Extend at least 12 inches horizontally beyond the top and bottom of the ramp?

Yes No

Measurement:

N/A

Return to a wall, guard, or landing surface? [505.10.1]

Yes No

N/A

Note: If a 12" extension would be hazardous (in circulation path), it is not required

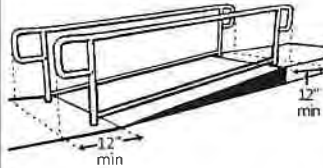

Photo #:

- Alter handrails
-
-

2.21 To prevent wheelchair casters and crutch tips from falling off:

Does the surface of the ramp extend at least 12 inches beyond the inside face of the handrail?
Or

Yes No

Measurement:

N/A

Yes No

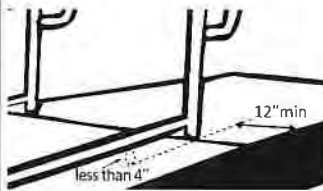
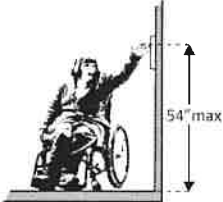

Photo #:



- Add curb
- Add barrier
- Extend ramp width
-
-

<p>Is there a curb or barrier that prevents the passage of a 4-inch diameter sphere? [405.9.1, 405.9.2]</p>	<p>Measurement: NA</p>		<p>Photo #:</p>	
-----------------------------------------------------------------------------------------------------------------	----------------------------	--	-----------------	--

Elevators – Full Size & LULA (limited use, limited application) LULA elevators are often used in alterations.

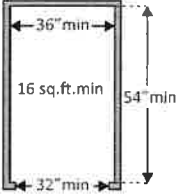
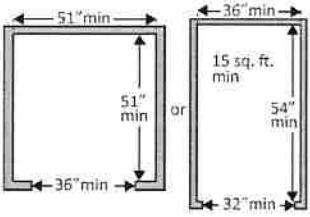
<p>2.22 If there is a full size or LULA elevator, are the call buttons no higher than 54 inches above the floor? [407.2.1.1]</p>	<p><input type="checkbox"/> Yes <input type="checkbox"/> No Measurement: NA</p>		<p>Photo #:</p>	<ul style="list-style-type: none"> • Change call button height • •
<p>2.23 If there is a full size or LULA elevator, does the sliding door reopen automatically when obstructed by an object or person?*</p>	<p><input type="checkbox"/> Yes <input type="checkbox"/> No NA</p>		<p>Photo #:</p>	<p>* If constructed before 3/15/2012 and manually operated, the door is not required to reopen automatically</p> <ul style="list-style-type: none"> • Install opener •

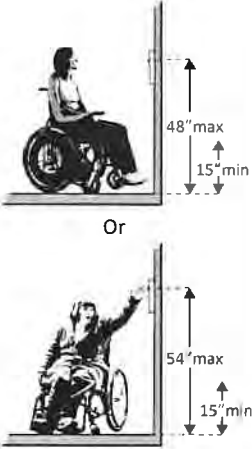
<p>2.24 If there is a LULA elevator with a swinging door:</p> <p>Is the door power-operated?</p> <p>Does the door remain open for at least 20 seconds when activated? [403.3.2]</p>	<p><input type="checkbox"/> Yes <input type="checkbox"/> No <i>N/A</i></p> <p><input type="checkbox"/> Yes <input type="checkbox"/> No <i>N/A</i></p> <p>Time: <i>N/A</i></p>		<p>Photo #:</p>	<ul style="list-style-type: none"> • Add power operated door • Adjust opening time
<p>2.25 If there is a full size elevator:</p> <p>Is the interior at least 54 inches deep by at least 36 inches wide with at least 16 sq. ft. of clear floor area?</p> <p>Is the door opening width at least 32 inches? [407.4.1 Exception]</p>	<p><input type="checkbox"/> Yes <input type="checkbox"/> No</p> <p>Measurement: <i>N/A</i></p> <p><input type="checkbox"/> Yes <input type="checkbox"/> No</p> <p>Measurement: <i>N/A</i></p>		<p>Photo #:</p>	<ul style="list-style-type: none"> • Replace elevator
<p>2.26 If there is a LULA elevator, is the interior:</p> <p>At least 51 inches deep by 51 inches wide with a door opening width of at least 36 inches?</p> <p>Or</p> <p>At least 54 inches deep by at least 36 inches wide with at least 15 sq. ft. of clear floor area and a door opening width of at least 32 inches? [408.4.1 Exceptions 1 and 2]</p>	<p><input type="checkbox"/> Yes <input type="checkbox"/> No</p> <p>Measurement: <i>N/A</i></p> <p><input type="checkbox"/> Yes <input type="checkbox"/> No</p> <p>Measurement: <i>N/A</i></p>		<p>Photo #:</p>	<ul style="list-style-type: none"> • Replace elevator

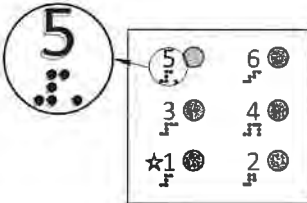
<p>2.27 If there is a full size or LULA elevator, are the in-car controls:</p> <p>No less than 15 inches and no greater 48 inches above the floor?</p> <p>Or</p> <p>Up to 54 inches above the floor for a parallel approach? [408.4.6, 407.4.6.1]</p>	<p><input type="checkbox"/> Yes <input type="checkbox"/> No</p> <p>Measurement: NA</p> <p><input type="checkbox"/> Yes <input type="checkbox"/> No</p> <p>Measurement: NA</p>		<p>Photo #:</p> <ul style="list-style-type: none"> • Change control height • •
<p>2.28 If there is a LULA elevator, are the in-car controls centered on a side wall? [408.4.6]</p>	<p><input type="checkbox"/> Yes <input type="checkbox"/> No</p> <p>Measurement: NA</p>		<p>Photo #:</p> <ul style="list-style-type: none"> • Reconfigure controls • •
<p>2.29 If there is a full size or LULA elevator:</p> <p>Are the car control buttons designated with raised characters?</p> <p>Are the car control buttons designated with Braille?</p>	<p><input type="checkbox"/> Yes <input type="checkbox"/> No</p> <p>NA</p> <p><input type="checkbox"/> Yes <input type="checkbox"/> No</p> <p>NA</p>		<ul style="list-style-type: none"> • Add raised characters • Add Braille •

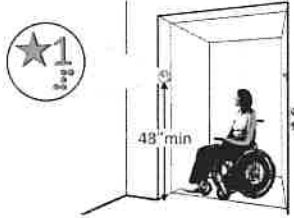
[407.4.7.1, 703.2]			Photo #:	
<p>2.30 If there is a full size or LULA elevator, are there audible signals which sound as the car passes or is about to stop at a floor? [407.4.8]</p>	<p><input type="checkbox"/> Yes <input type="checkbox"/> No N/A</p>		Photo #:	<ul style="list-style-type: none"> • Install audible signals • •
<p>2.31 If there is a full size or LULA elevator:</p> <p>Is there a sign on both door jambs at every floor identifying the floor?</p> <p>Is there a tactile star on both jambs at the main entry level?</p> <p>Do text characters contrast with their backgrounds?</p> <p>Are text characters raised?</p> <p>Is there Braille?</p> <p>Is the sign mounted between 48 inches to the baseline of the lowest character and 60 inches to the baseline of the highest character above the floor?*</p> <p>[407.2.3, 408.2.3]</p>	<p><input type="checkbox"/> Yes <input type="checkbox"/> No N/A</p> <p><input type="checkbox"/> Yes <input type="checkbox"/> No N/A</p> <p><input type="checkbox"/> Yes <input type="checkbox"/> No N/A</p> <p><input type="checkbox"/> Yes <input type="checkbox"/> No N/A</p> <p><input type="checkbox"/> Yes <input type="checkbox"/> No N/A</p> <p><input type="checkbox"/> Yes <input type="checkbox"/> No N/A</p> <p>Measurement: N/A</p>		Photo #:	<ul style="list-style-type: none"> • Install signs • Change sign height • • <p>* If constructed before 3/15/2012 and mounted no higher than 60 inches to the centerline of the sign, relocation is not required</p>

Platform Lifts

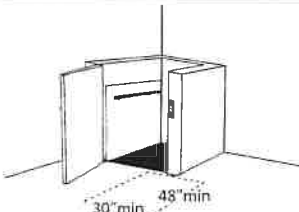
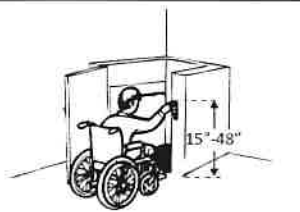
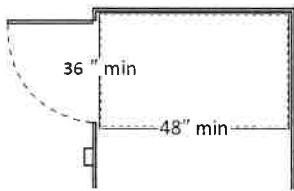
<p>2.32 If a lift is provided, can it be used without assistance from others? [410.1]</p>	<p><input type="checkbox"/> Yes <input type="checkbox"/> No</p> <p>NA</p>		<p>Photo #:</p>	<ul style="list-style-type: none"> • Reconfigure so independently operable • •
<p>2.33 Is there a clear floor space at least 30 inches wide by at least 48 inches long for a person using a wheelchair to approach and reach the controls to use the lift? [410.5]</p>	<p><input type="checkbox"/> Yes <input type="checkbox"/> No</p> <p>Measurement:</p> <p>NA</p>		<p>Photo #:</p>	<ul style="list-style-type: none"> • Remove obstructions • •
<p>2.34 Are the lift controls no less than 15 inches and no greater than 48 inches above the floor? [410.5]</p>	<p><input type="checkbox"/> Yes <input type="checkbox"/> No</p> <p>Measurement:</p> <p>NA</p>		<p>Photo #:</p>	<ul style="list-style-type: none"> • Change control height • •
<p>2.35 Is there a clear floor space at least 36 inches wide by at least 48 inches long inside the lift? [410.3]</p>	<p><input type="checkbox"/> Yes <input type="checkbox"/> No</p> <p>Measurement:</p> <p>NA</p>		<p>Photo #:</p>	<ul style="list-style-type: none"> • Replace lift • •

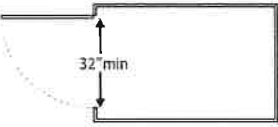
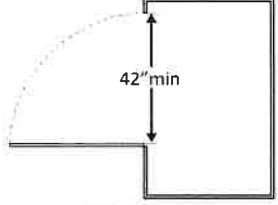
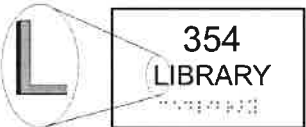
<p>2.36 If there is an end door, is the clear opening width at least 32 inches? [410.6]</p>	<p><input type="checkbox"/> Yes <input type="checkbox"/> No</p> <p>Measurement: <i>N/A</i></p>		<p>Photo #:</p>	<ul style="list-style-type: none"> • Alter door width • •
<p>2.37 If there is a side door, is the clear opening width at least 42 inches? [410.6]</p>	<p><input type="checkbox"/> Yes <input type="checkbox"/> No</p> <p>Measurement: <i>N/A</i></p>		<p>Photo #:</p>	<ul style="list-style-type: none"> • Alter door width • •
<p>Signs "Tactile characters" are read using touch, i.e. raised characters and Braille.</p>				
<p>2.38 If there are signs designating permanent rooms and spaces not likely to change over time, e.g. room numbers and letters, room names, and exit signs: [216.2]</p> <p>Do text characters contrast with their backgrounds? [703.5]</p> <p>Are text characters raised? [703.2]</p> <p>Is there Braille? [703.3]</p> <p>Is the sign mounted:</p>	<p><input type="checkbox"/> Yes <input type="checkbox"/> No <i>N/A</i></p> <p><input type="checkbox"/> Yes <input type="checkbox"/> No <i>N/A</i></p> <p><input type="checkbox"/> Yes <input type="checkbox"/> No <i>N/A</i></p>		<p>Photo #:</p>	<ul style="list-style-type: none"> • Install tactile sign • Relocate sign •

On the wall on the latch side of the door?
[703.4.2]

Yes No

NA

Note: Signs are permitted on the push side of doors with closers and without hold-open devices.

With clear floor space beyond the arc of the door swing between the closed position and 45-degree open position, at least 18 x 18 inches centered on the tactile characters?*

Yes No

Measurement:

NA

So the baseline of the lowest character is at least 48 inches above the floor and the baseline of the highest character is no more than 60 inches above the floor? *

Yes No

Measurement:

NA

Note: If the sign is at double doors with one active leaf, the sign should be on the inactive leaf; if both leaves are active, the sign should be on the wall to the right of the right leaf.

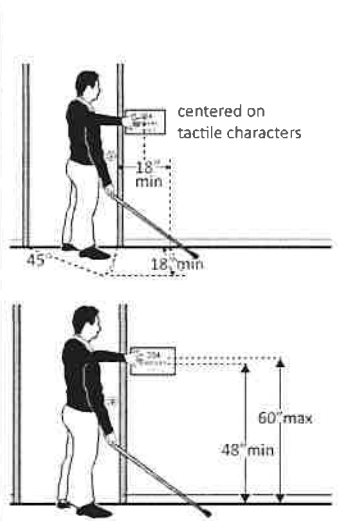
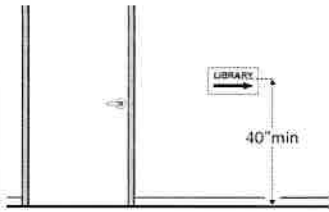
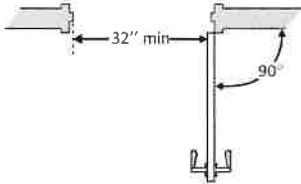
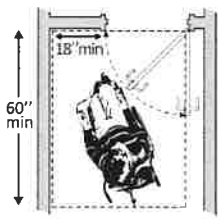
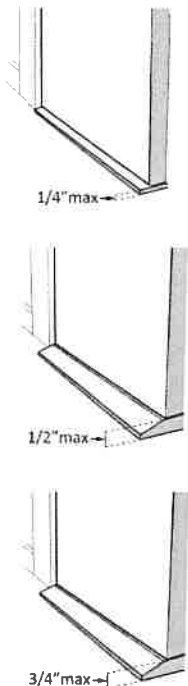



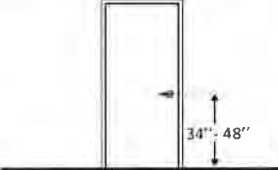

Photo #:

*If constructed before 3/15/2012 and a person may approach within 3 inches of the sign without encountering protruding objects or standing within the door swing, relocation not required

*If constructed before 3/15/2012 and mounted no higher than 60 inches to the centerline of the sign, relocation not required

<p>2.39 If there are signs that provide direction to or information about interior spaces: Do text characters contrast with their backgrounds? [703.5.1] Is the sign mounted so that characters are at least 40 inches above the floor? [703.5.6] Note: Raised characters and Braille are not required.</p>	<p><input type="checkbox"/> Yes <input type="checkbox"/> No NA</p> <p><input type="checkbox"/> Yes <input type="checkbox"/> No Measurement: NA</p>		<p>Photo #:</p>	<ul style="list-style-type: none"> • Install signs with contrasting characters • Change sign height
Interior Doors – to classrooms, medical exam rooms, conference rooms, etc.				
<p>2.40 Is the door opening width at least 32 inches clear, between the face of the door and the stop, when the door is open 90 degrees? [404.2.3]</p>	<p><input type="checkbox"/> Yes <input type="checkbox"/> No Measurement: NA</p>		<p>Photo #:</p>	<ul style="list-style-type: none"> • Install offset hinges • Alter the doorway
<p>2.41 If there is a front approach to the pull side of the door, is there at least 18 inches of maneuvering clearance beyond the latch side plus at least 60 inches clear depth? Note: See 2010 Standards 404.2.4 for maneuvering clearance requirements on the push side of the door and side approaches to the pull side of the door.</p>	<p><input type="checkbox"/> Yes <input type="checkbox"/> No Measurement: NA</p>		<p>Photo #:</p>	<ul style="list-style-type: none"> • Remove obstructions • Reconfigure walls • Add automatic door opener

<p>On both sides of the door, is the floor surface of the maneuvering clearance level (no steeper than 1:48)? [404.2.4]</p>	<p><input type="checkbox"/> Yes <input type="checkbox"/> No Measurement: NA</p>		<p>Photo #:</p>	
<p>2.42 If the threshold is vertical is it no more than ¼ inch high? Or No more than ½ inch high with the top ¼ inch beveled no steeper than 1:2, if the threshold was installed on or after the 1991 ADA Standards went into effect (1/26/93)? Or No more than ¾ inch high with the top ½ inch beveled no steeper than 1:2, if the threshold was installed before the 1991 ADA Standards went into effect (1/26/93)? [404.2.5, 303.2] Note: The first ¼ inch of the ½ or ¾ inch threshold may be vertical; the rest must be beveled.</p>	<p><input type="checkbox"/> Yes <input type="checkbox"/> No Measurement: NA <input type="checkbox"/> Yes <input type="checkbox"/> No Measurement: NA <input type="checkbox"/> Yes <input type="checkbox"/> No Measurement: NA</p>		<p>Photo #:</p>	<ul style="list-style-type: none"> • Remove or replace threshold • •

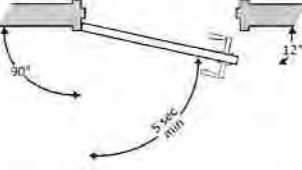
<p>2.43 Is the door equipped with hardware that is operable with one hand and does not require tight grasping, pinching or twisting of the wrist?</p> <p>Door handle?</p> <p>Lock (if provided)? [404.2.7]</p>	<p><input type="checkbox"/> Yes <input type="checkbox"/> No <i>NA</i></p> <p><input type="checkbox"/> Yes <input type="checkbox"/> No <i>NA</i></p> <p><input type="checkbox"/> Yes <input type="checkbox"/> No <i>NA</i></p>		<p>Photo #:</p>	<ul style="list-style-type: none"> • Replace inaccessible knob with lever, loop or push hardware • Add automatic door opener
<p>2.44 Are the operable parts of the hardware no less than 34 inches and no greater than 48 inches above the floor? [404.2.7]</p>	<p><input type="checkbox"/> Yes <input type="checkbox"/> No</p> <p>Measurement: <i>NA</i></p>		<p>Photo #:</p>	<ul style="list-style-type: none"> • Change hardware height
<p>2.45 Can the door be opened easily (5 pounds maximum force)? [404.2.9]</p> <p>Note: You can use a pressure gauge or fish scale to measure force. If you do not have one you will need to judge whether the door is easy to open.</p>	<p><input type="checkbox"/> Yes <input type="checkbox"/> No</p> <p>Measurement: <i>NA</i></p>		<p>Photo #:</p>	<ul style="list-style-type: none"> • Adjust or replace closers • Install lighter doors • Install power-assisted or automatic door openers
<p>2.46 If the door has a closer, does it take at least 5 seconds to close from an open position of 90 degrees to a position of 12 degrees from the latch? [404.2.8.1]</p>	<p><input type="checkbox"/> Yes <input type="checkbox"/> No</p> <p>Measurement: <i>NA</i></p>		<p>Photo #:</p>	<ul style="list-style-type: none"> • Adjust closer

Rooms and Spaces – stores, supermarkets, libraries, etc.

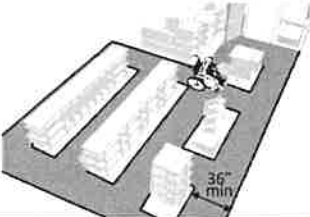
<p>2.47 Are aisles and pathways to goods and services, and to one of each type of sales and service counters, at least 36 inches wide? [403.5.1]</p>	<p><input type="checkbox"/> Yes <input type="checkbox"/> No Measurement: NA</p>		<p>Photo #:</p>	<ul style="list-style-type: none"> • Rearrange goods, equipment and furniture • •
-----------------------------------------------------------------------------------------------------------------------------------------------------------------	-----------------------------------------------------------------------------------------	-----------------------------------------------------------------------------------	-----------------	--------------------------------------------------------------------------------------------------------------------

<p>2.48 Are floor surfaces stable, firm and slip resistant? [302.1]</p>	<p><input type="checkbox"/> Yes <input type="checkbox"/> No Measurement: NA</p>		<p>Photo #:</p>	<ul style="list-style-type: none"> • Change floor surface • •
------------------------------------------------------------------------------------	-----------------------------------------------------------------------------------------	--	-----------------	------------------------------------------------------------------------------------------------

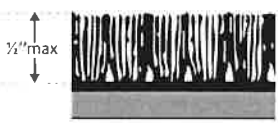
<p>2.49 If there is carpet: Is it no higher than 1/2 inch? Is it securely attached along the edges? [302.2]</p>	<p><input type="checkbox"/> Yes <input type="checkbox"/> No Measurement: NA <input type="checkbox"/> Yes <input type="checkbox"/> No Measurement: NA</p>		<p>Photo #:</p>	<ul style="list-style-type: none"> • Replace carpet • •
----------------------------------------------------------------------------------------------------------------------------------------------	-----------------------------------------------------------------------------------------------------------------------------------------------------------------------------------	-------------------------------------------------------------------------------------	-----------------	------------------------------------------------------------------------------------------

Controls – light switches, security and intercom systems, emergency/alarm boxes, etc.

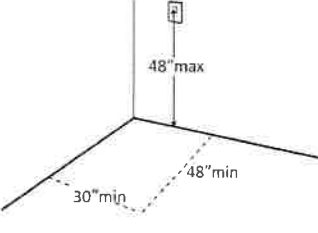
<p>2.50 Is there a clear floor space at least 30 inches wide by at least 48 inches long for a forward or parallel approach? [305.3] Are the operable parts no higher than 48 inches above the floor? * [309.3, 308]</p>	<p><input type="checkbox"/> Yes <input type="checkbox"/> No Measurement: NA <input type="checkbox"/> Yes <input type="checkbox"/> No Measurement: NA</p>		<p>Photo #:</p>	<ul style="list-style-type: none"> • Change height of control • • <p>*If constructed before 3/15/2012 and a parallel approach is provided, controls can be 54 inches above the floor</p>
-------------------------------------------------------------------------------------------------------------------------------------------------------------------------------------------------------------------------------------------------	-----------------------------------------------------------------------------------------------------------------------------------------------------------------------------------	--------------------------------------------------------------------------------------	-----------------	---------------------------------------------------------------------------------------------------------------------------------------------------------------------------------------------------------------------------

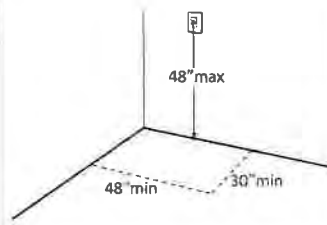

Photo #:

2.51 Can the control be operated with one hand and without tight grasping, pinching, or twisting of the wrist? [309.4]

Yes No

NA

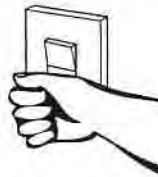

Photo #:

- Replace control
-
-

Seating: Assembly Areas – theaters, auditoriums, stadiums, theater style classrooms, etc.

2.52 Are an adequate number of wheelchair spaces provided? [221.2.1]

Yes No

Total #: NA

Wheelchair #: NA

# of Seats	Wheelchair Spaces
4 - 25	1
26 - 50	2
51 - 150	4
151 - 300	5
300+ see 2010 Standards 221.2.1.	

Photo #:

- Reconfigure to add wheelchair spaces
-
-

2.53 Are wheelchair spaces dispersed to allow location choices and viewing angles equivalent to other seating, including specialty seating areas that provide distinct services and amenities? [221.2.3]

Yes No

NA

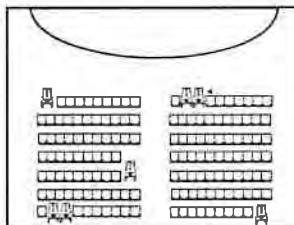

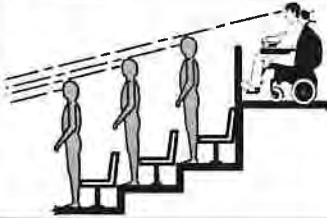

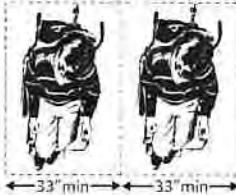
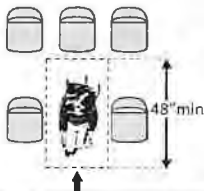
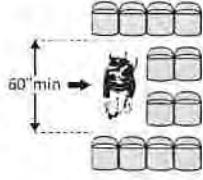
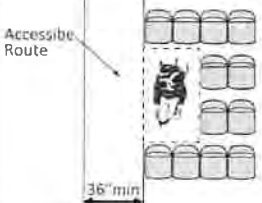





Photo #:

- Reconfigure to disperse wheelchair spaces
-
-

			Photo #:	
<p>2.54 Where people are expected to remain seated, do people in wheelchair spaces have a clear line of sight over and between the heads of others in front of them? [802.2.1.1, 802.1.1.2]</p>	<p><input type="checkbox"/> Yes <input type="checkbox"/> No</p> <p>NA</p>		Photo #:	<ul style="list-style-type: none"> • Alter for line of sight • •
<p>2.55 Where people are expected to stand, do people in wheelchair spaces have a clear line of sight over and between the heads of others in front of them? [802.2.2.1, 802.1.2.2]</p>	<p><input type="checkbox"/> Yes <input type="checkbox"/> No</p> <p>NA</p>		Photo #:	<ul style="list-style-type: none"> • Alter for line of sight • •
<p>2.56 If there is a single wheelchair space, is it at least 36 inches wide? [802.1.2]</p>	<p><input type="checkbox"/> Yes <input type="checkbox"/> No</p> <p>Measurement:</p> <p>NA</p>		Photo #:	<ul style="list-style-type: none"> • Alter space • •

<p>2.57 If there are two adjacent wheelchair spaces, are they each at least 33 inches wide? [802.1.2]</p>	<p><input type="checkbox"/> Yes <input type="checkbox"/> No</p> <p>Measurement: NA</p>		<p>Photo #:</p>	<ul style="list-style-type: none"> • Alter spaces • •
<p>2.58 If the wheelchair space can be entered from the front or rear, is it at least 48 inches deep? [802.1.3]</p>	<p><input type="checkbox"/> Yes <input type="checkbox"/> No</p> <p>Measurement: NA</p>		<p>Photo #:</p>	<ul style="list-style-type: none"> • Alter space • •
<p>2.59 If the wheelchair space can only be entered from the side, is it at least 60 inches deep? [802.1.3]</p>	<p><input type="checkbox"/> Yes <input type="checkbox"/> No</p> <p>Measurement: NA</p>		<p>Photo #:</p>	<ul style="list-style-type: none"> • Alter space • •
<p>2.60 Do wheelchair spaces adjoin, but not overlap, accessible routes? [802.1.4]</p>	<p><input type="checkbox"/> Yes <input type="checkbox"/> No</p> <p>Measurement: NA</p>		<p>Photo #:</p>	<ul style="list-style-type: none"> • Alter spaces • •

<p>2.61 Is there at least one companion seat for each wheelchair space? [221.3]</p>	<p><input type="checkbox"/> Yes <input type="checkbox"/> No <i>NA</i></p>		<p>Photo #:</p>	<ul style="list-style-type: none"> • Add companion seats • •
<p>2.62 Is the companion seat located so the companion is shoulder-to-shoulder with the person in a wheelchair? [802.3.1]</p>	<p><input type="checkbox"/> Yes <input type="checkbox"/> No <i>NA</i></p>		<p>Photo #:</p>	<ul style="list-style-type: none"> • Alter seating • •
<p>2.63 Is the companion seat equivalent in size, quality, comfort and amenities to seating in the immediate area? [802.3.2]</p>	<p><input type="checkbox"/> Yes <input type="checkbox"/> No <i>NA</i></p>		<p>Photo #:</p>	<ul style="list-style-type: none"> • Add equivalent seating • •
<p>Seating: At dining surfaces (restaurants, cafeterias, bars, etc.) and non-employee work surfaces (libraries, conference rooms, etc.)</p>				
<p>2.64 Are at least 5%, but no fewer than one, of seating and standing spaces accessible for people who use wheelchairs? [226.1]</p>	<p><input type="checkbox"/> Yes <input type="checkbox"/> No Total #: <i>NA</i> Wheelchair #: <i>NA</i></p>		<p>Photo #:</p>	<ul style="list-style-type: none"> • Alter to provide accessible spaces • •
<p>2.65 Is there a route at least 36 inches wide to accessible seating? [403.5.1]</p>	<p><input type="checkbox"/> Yes <input type="checkbox"/> No Measurement: <i>NA</i></p>		<p>Photo #:</p>	<ul style="list-style-type: none"> • Widen route • •

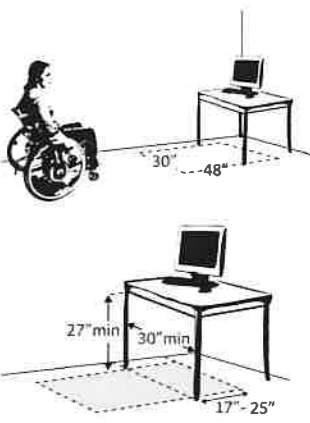
<p>2.66 At the accessible space(s), is the top of the accessible surface no less than 28 inches and no greater than 34 inches above the floor? [902.3]</p> <p>Note: If for children, the top should be no less than 26 inches and no greater than 30 inches above the floor.</p>	<p><input type="checkbox"/> Yes <input type="checkbox"/> No</p> <p>Measurement:</p> <p>N/A</p>		<p>Photo #:</p>	<ul style="list-style-type: none"> • Alter surface height • •
<p>2.67 Is there a clear floor space at least 30 inches wide by at least 48 inches long for a forward approach? [305.3]</p> <p>Does it extend no less than 17 inches and no greater than 25 inches under the surface?</p> <p>Is there knee space at least 27 inches high and at least 30 inches wide? [306.2, 306.3]</p> <p>Note: If for children, the knee space may be 24 inches high.</p>	<p><input type="checkbox"/> Yes <input type="checkbox"/> No</p> <p>Measurement:</p> <p>N/A</p> <p><input type="checkbox"/> Yes <input type="checkbox"/> No</p> <p>Measurement:</p> <p>N/A</p> <p><input type="checkbox"/> Yes <input type="checkbox"/> No</p> <p>Measurement:</p> <p>N/A</p>		<p>Photo #:</p>	<ul style="list-style-type: none"> • Alter table or work surface • Add accessible table or work surface •

Seating: General – reception areas, waiting rooms, etc.

2.68 Is there at least one space at least 36 inches wide by at least 48 inches long for a person in a wheelchair?
[802.1.2, 802.1.3]

Yes No

Measurement:

NA

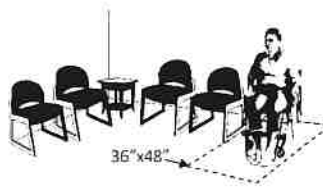

Photo #:

- Move furniture and equipment to provide space
-
-

Benches – In locker rooms, dressing rooms, fitting rooms This section does not apply to any other benches.

2.69 In locker rooms, dressing rooms and fitting rooms, is there at least one room with a bench?
[222.1, 803.4]

Yes No

NA

Photo #:

- Add bench
-
-

2.70 Is there a clear floor space at least 30 inches wide by at least 48 inches long at the end of the bench and parallel to the short axis of the bench?

Yes No

Measurement:

NA

Is the bench seat at least 42 inches long and no less than 20 inches and no greater than 24 inches deep?

Yes No

Measurement:

NA

Does the bench have back support or is it affixed to a wall?

Yes No

NA

Is the top of the bench seat no less than 17 inches and no greater than 19 inches above the floor?
[903]

Yes No

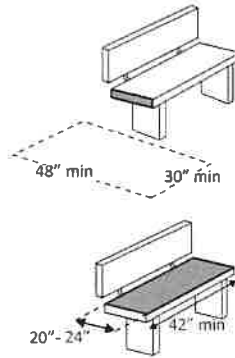

Measurement:

NA

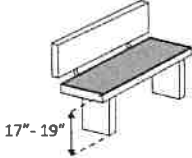
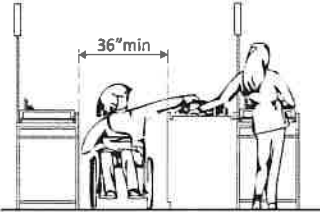
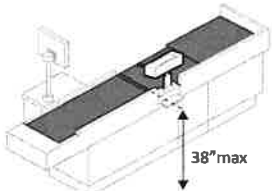
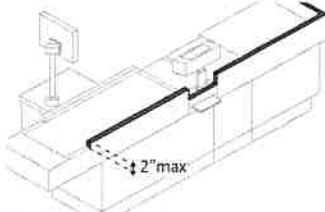

- Move bench
- Replace bench
- Affix bench to wall
-
-

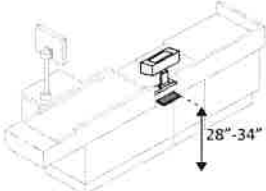
		 <p>17" - 19"</p>	Photo #:	
Check-Out Aisles – supermarkets, large retail stores, etc.				
<p>2.71 Is the aisle at least 36 inches wide? [904.3.1]</p>	<p><input type="checkbox"/> Yes <input type="checkbox"/> No</p> <p>Measurement: <i>N/A</i></p>	 <p>36" min</p>	Photo #:	<ul style="list-style-type: none"> • Widen aisle • •
<p>2.72 Is the counter surface of at least one aisle no higher than 38 inches above the floor? [904.3.2]</p>	<p><input type="checkbox"/> Yes <input type="checkbox"/> No</p> <p>Measurement: <i>N/A</i></p>	 <p>38" max</p>	Photo #:	<ul style="list-style-type: none"> • Lower counter • •
<p>2.73 Is the top of the counter edge protection no higher than 2 inches above the counter surface? [904.3.2]</p>	<p><input type="checkbox"/> Yes <input type="checkbox"/> No</p> <p>Measurement: <i>N/A</i></p>	 <p>2" max</p>	Photo #:	<ul style="list-style-type: none"> • Lower edge protection • •

<p>2.74 If there is a check writing surface, is the top no less than 28 inches and no greater than 34 inches above the floor? [904.3.3]</p>	<p><input type="checkbox"/> Yes <input type="checkbox"/> No Measurement: <i>NA</i></p>		<p>Photo #:</p>	<ul style="list-style-type: none"> • Alter check writing surface • •
<p>2.75 If there is more than one check-out aisle is there a sign with the International Symbol of Accessibility at the accessible aisle? [216.11]</p>	<p><input type="checkbox"/> Yes <input type="checkbox"/> No <i>NA</i></p>		<p>Photo #:</p>	<ul style="list-style-type: none"> • Add sign • •

Sales & Service Counters – banks, stores, dry cleaners, auto repair shops, fitness clubs, etc.

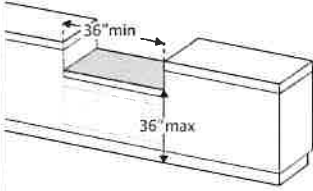
<p>2.76 Is there a portion of at least one of each type of counter that is: No higher than 36 inches above the floor? At least 36 inches long? [904.4.1]</p>	<p><input type="checkbox"/> Yes <input type="checkbox"/> No Measurement: <i>NA</i> <input type="checkbox"/> Yes <input type="checkbox"/> No Measurement: <i>NA</i></p>		<p>Photo #:</p>	<ul style="list-style-type: none"> • Lower section of counter • Lengthen section of counter •
---------------------------------------------------------------------------------------------------------------------------------------------------------------------------------------	-------------------------------------------------------------------------------------------------------------------------------------------------------------------------------------------------	-------------------------------------------------------------------------------------	-----------------	--------------------------------------------------------------------------------------------------------------------------------

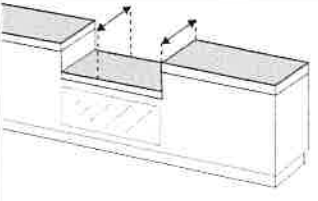
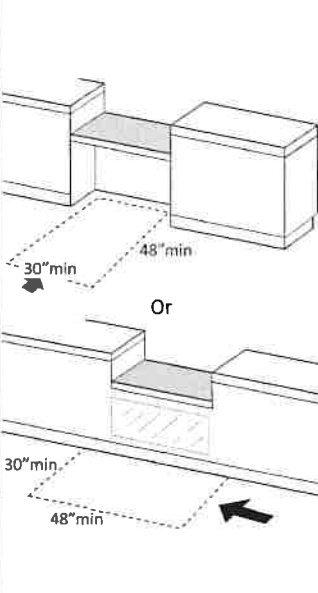
<p>2.77 Does the accessible portion of the counter extend the same depth as the counter top? [904.4]</p>	<p><input type="checkbox"/> Yes <input type="checkbox"/> No</p> <p>Measurement: <i>NA</i></p>		<p>Photo #:</p>	<ul style="list-style-type: none"> • Alter accessible portion • •
<p>2.78 Is there a clear floor space at least 30 inches wide by at least 48 inches long for a forward or parallel approach? [904.4]</p>	<p><input type="checkbox"/> Yes <input type="checkbox"/> No</p> <p><input type="checkbox"/> Parallel Measurement: <i>NA</i></p> <p><input type="checkbox"/> Forward Measurement: <i>NA</i></p>		<p>Photo #:</p>	<ul style="list-style-type: none"> • Reconfigure to provide a parallel or forward approach • •

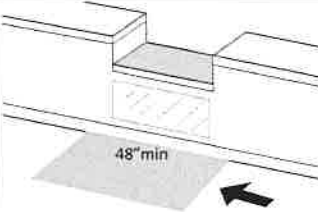
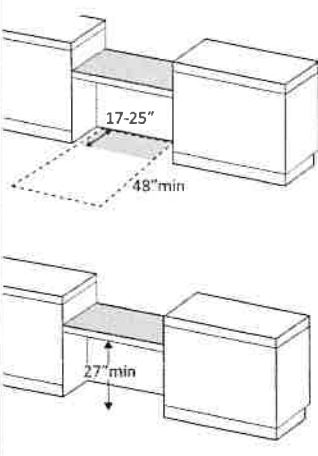
<p>2.79 For a parallel approach, is the clear floor space positioned with the 48 inches adjacent to the accessible length of counter? [904.4.1]</p>	<p><input type="checkbox"/> Yes <input type="checkbox"/> No Measurement: NA</p>		<p>Photo #:</p>	<ul style="list-style-type: none"> • If a parallel approach is not possible, a forward approach is required • •
<p>2.80 For a forward approach: Do no less than 17 and no greater than 25 inches of the clear floor space extend under the accessible length of the counter? [306.2.2, 306.2.3] Is there at least 27 inches clearance from the floor to the bottom of the counter? [306.3.1]</p>	<p><input type="checkbox"/> Yes <input type="checkbox"/> No Measurement: NA <input type="checkbox"/> Yes <input type="checkbox"/> No Measurement: NA</p>		<p>Photo #:</p>	<ul style="list-style-type: none"> • Reconfigure to provide knee clearance • •

Food Service Lines – in cafeterias, salad bars, eat-in fast food establishments, etc.

2.81 Does at least one of each type of self-service shelf or dispensing device for tableware, dishware, condiments, food and beverages have a forward or parallel approach? [904.5.1]

- Yes No
- Forward
- Parallel

N/A

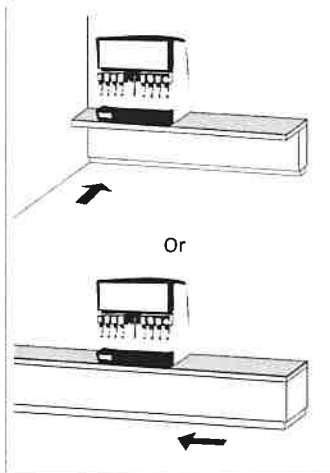

Photo #:

- Reconfigure to provide approach
-
-

2.82 If there is an unobstructed parallel approach, is the shelf or dispensing device no higher than 48 inches above the floor? [308.3.1]

- Yes No
- Measurement:

N/A

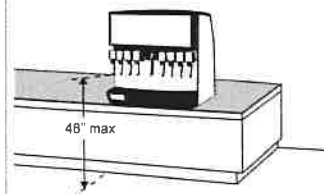

Photo #:

- Lower shelf and/or dispensing device
-
-

2.83 If there is a shallow obstruction no deeper than 10 inches with a parallel approach, is the shelf or dispensing device no higher than 48 inches above the floor? [308.3.1]

- Yes No
- Measurement:

N/A

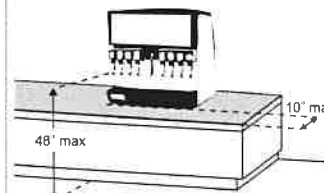
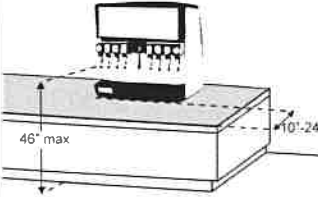
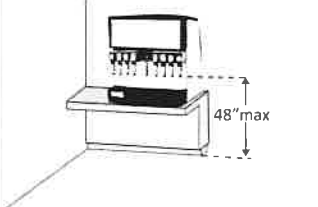
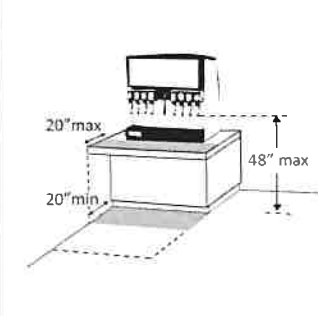
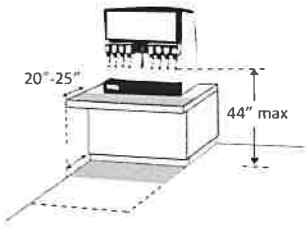
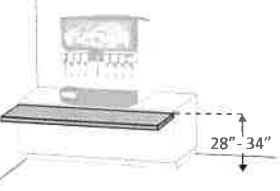

Photo #:

- Lower shelf and/or dispensing device
-
-

<p>2.84 If there is an obstruction no less than 10 inches and no greater than 24 inches deep with a parallel approach, is the shelf or dispensing device no higher than 46 inches above the floor? [308.3.2]</p>	<p><input type="checkbox"/> Yes <input type="checkbox"/> No Measurement: <i>N/A</i></p>		<p>Photo #:</p>	<ul style="list-style-type: none"> • Lower shelf and/or dispensing device • •
<p>2.85 If there is an unobstructed forward approach, is the shelf or dispensing device no higher than 48 inches above the floor? [308.2.1]</p>	<p><input type="checkbox"/> Yes <input type="checkbox"/> No Measurement: <i>N/A</i></p>		<p>Photo #:</p>	<ul style="list-style-type: none"> • Lower shelf and/or dispensing device • •
<p>2.86 If there is an obstruction no deeper than 20 inches with a forward approach: Does clear floor space extend under the obstruction that is at least the same depth as the obstruction? Is the shelf or dispensing device no higher than 48 inches above the floor? [904.5.1]</p>	<p><input type="checkbox"/> Yes <input type="checkbox"/> No Measurement: <i>N/A</i> <input type="checkbox"/> Yes <input type="checkbox"/> No Measurement: <i>N/A</i></p>		<p>Photo #:</p>	<ul style="list-style-type: none"> • Reconfigure to provide knee space • Lower shelf and/or dispensing device •

<p>2.87 If the obstruction is no less than 20 inches and no greater than 25 inches deep with a forward approach:</p> <p>Does clear floor space extend under the obstruction that is at least the same depth as the obstruction?</p> <p>Is the shelf or dispensing device no higher than 44 inches above the floor? [904.5.1]</p>	<p><input type="checkbox"/> Yes <input type="checkbox"/> No Measurement: NA</p> <p><input type="checkbox"/> Yes <input type="checkbox"/> No Measurement: NA</p>		<p>Photo #:</p> <ul style="list-style-type: none"> • Reconfigure to provide knee space • Lower shelf and/or dispensing device •
<p>2.88 If there is a tray slide, is the top no less than 28 inches and no greater than 34 inches above the floor? [904.5.2]</p>	<p><input type="checkbox"/> Yes <input type="checkbox"/> No Measurement: NA</p>		<p>Photo #:</p> <ul style="list-style-type: none"> • Reconfigure • •
	<p><input type="checkbox"/> Yes <input type="checkbox"/> No</p>		<p>Photo #:</p> <ul style="list-style-type: none"> • • •
	<p><input type="checkbox"/> Yes <input type="checkbox"/> No</p>		<p>Photo #:</p> <ul style="list-style-type: none"> • • •

NO
PUBLIC BATHROOMS

The ADA Checklist for Existing Facilities

Priority 3 - Toilet Rooms

Based on the 2010 ADA Standards for Accessible Design

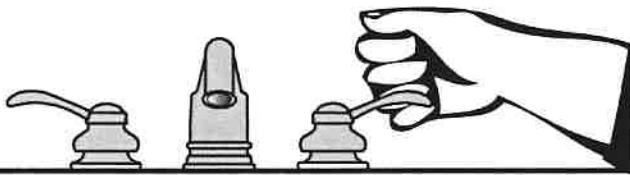

Project ADA TRANSITION PLAN

Building WATER TREATMENT PLANT

Location WEAVERVILLE H.C.

Date 4-21-2020

Surveyors ALAN F. MACKAY

Contact Information TRENT DUNCAN

When toilet rooms are open to the public they should be accessible to people with disabilities.



Institute for Human Centered Design
www.HumanCenteredDesign.org
Copyright © 2016



ADA National Network
Questions on the ADA 800-949-4232 voice/tty
www.ADAchecklist.org

This checklist was produced by the New England ADA Center, a project of the Institute for Human Centered Design and a member of the ADA National Network. This checklist was developed under a grant from the Department of Education, NIDRR grant number H133A060092-09A. However the contents do not necessarily represent the policy of the Department of Education, and you should not assume endorsement by the Federal Government.

Questions or comments on the checklist contact the New England ADA Center at 617-695-0085 voice/tty or ADAinfo@NewEnglandADA.org

For the full set of checklists, including the checklists for recreation facilities visit www.ADAchecklist.org.

Copyright © 2016 ADA Checklist for Existing Materials. You can freely reproduce and distribute this content. Include proper attribution. But you must get permission before using this content as a fee-based product.



Priority 3 – Toilet Rooms		Comments	Possible Solutions
<p>3.1 If toilet rooms are available to the public, is at least one toilet room accessible? (Either one for each sex, or one unisex.)</p> <p>Note: If toilet rooms are chiefly for children, e.g., in elementary schools and day care centers, use the children’s specifications in Toilets - 604.1, 604.8, 604.9, 609.4 and Lavatories and Sinks – 606.2.</p>	<input type="checkbox"/> Yes <input type="checkbox"/> No <p>NA</p>	<p>Photo #:</p>	<ul style="list-style-type: none"> • Reconfigure toilet rooms • Combine toilet rooms to create one unisex accessible toilet room
<p>3.2 Are there signs at inaccessible toilet rooms that give directions to accessible toilet rooms? [See 2010 ADA Standards for Accessible Design – 216.8]</p>	<input type="checkbox"/> Yes <input type="checkbox"/> No <p>NA</p>	 <p>Photo #:</p>	<ul style="list-style-type: none"> • Install signs
<p>3.3 If not all toilet rooms are accessible, is there a sign at the accessible toilet room with the International Symbol of Accessibility? [216.8]</p>	<input type="checkbox"/> Yes <input type="checkbox"/> No <p>NA</p>	 <p>Photo #:</p>	<ul style="list-style-type: none"> • Install sign
Accessible Route			
<p>3.4 Is there an accessible route to the accessible toilet room? [206.2.4]</p>	<input type="checkbox"/> Yes <input type="checkbox"/> No <p>NA</p>		<ul style="list-style-type: none"> • Alter route

Photo #:

Signs at Toilet Rooms

3.5 Do text characters contrast with their backgrounds? [703.5]

Yes No

N/A

Are text characters raised? [703.2]

Yes No

N/A

Is there Braille? [703.3]

Yes No

N/A

Is the sign mounted:
On the wall on the latch side of the door? [703.4.2]

Yes No

N/A

Note: Signs are permitted on the push side of doors with closers and without hold-open devices.

With clear floor space beyond the arc of the door swing between the closed position and 45-degree open position, at least 18 x 18 inches centered on the tactile characters? * [703.4.2]

Yes No

Measurement:

N/A

So the baseline of the lowest character is at least 48 inches above the floor and the

Yes No

Measurement:

N/A

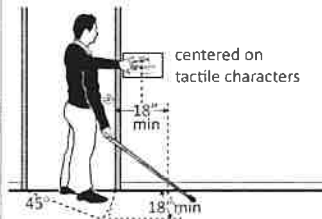
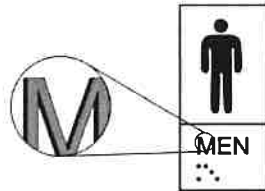

- Install tactile sign
- Relocate sign
-

*If constructed before 3/15/2012 and a person may approach within 3 inches of the sign without encountering protruding objects or standing within the door swing, relocation not required

ADA Checklist for Existing Facilities

Priority 3 – Toilet Rooms

baseline of the highest character is no more than 60 inches above the floor? * [703.4.1]

Note: If the sign is at double doors with one active leaf, the sign should be on the inactive leaf; if both leaves are active, the sign should be on the wall to the right of the right leaf.

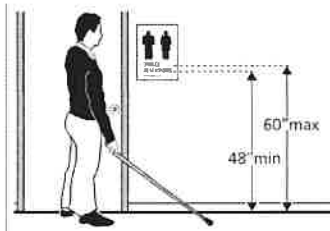

Photo #:

*If constructed before 3/15/2012 and mounted no higher than 60 inches to the centerline of the sign, relocation is not required

Entrance

3.6 Is the door opening width at least 32 inches clear, between the face of the door and the stop, when the door is open 90 degrees? [404.2.3]

Yes No

Measurement:

NA

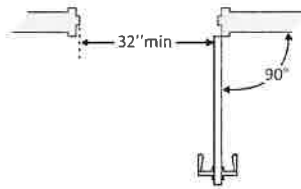

Photo #:

- Install offset hinges
- Alter the doorway
-

3.7 If there is a front approach to the pull side of the door is there at least 18 inches of maneuvering clearance beyond the latch side plus 60 inches clear depth?

Yes No

Measurement:

NA

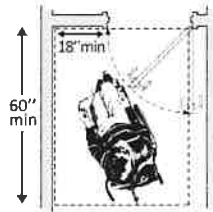
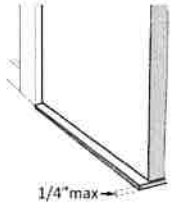
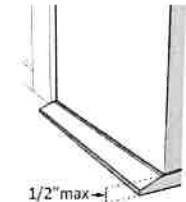
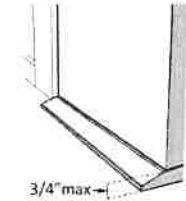



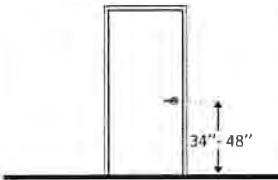

Photo #:

- Remove obstructions
- Reconfigure walls
- Add automatic door opener

Note: See 2010 Standards 404.2.4 for maneuvering clearance requirements on the push side of the door and side approaches to the pull side of the door

On both sides of the door, is the

<p>floor surface of the maneuvering clearance level (no steeper than 1:48)? [404.2.4]</p>	<p><input type="checkbox"/> Yes <input type="checkbox"/> No</p>	<p>Measurement: N/A</p>	<p>Photo #:</p>	
<p>3.8 If the threshold is vertical is it no more than ¼ inch high? Or No more than ½ inch high with the top ¼ inch beveled no steeper than 1:2, if the threshold was installed on or after the 1991 ADA Standards went into effect (1/26/93)? Or No more than ¾ inch high with the top ½ inch beveled no steeper than 1:2, if the threshold was installed before the 1991 ADA Standards went into effect (1/26/93)? [404.2.5, 303.2]</p>	<p><input type="checkbox"/> Yes <input type="checkbox"/> No</p>	<p>Measurement: N/A</p>	 <p>1/4" max</p>	<ul style="list-style-type: none"> • Remove or replace threshold • •
<p>No more than ¾ inch high with the top ½ inch beveled no steeper than 1:2, if the threshold was installed before the 1991 ADA Standards went into effect (1/26/93)? [404.2.5, 303.2]</p>	<p><input type="checkbox"/> Yes <input type="checkbox"/> No</p>	<p>Measurement: N/A</p>	 <p>1/2" max</p>	
<p>Note: The first ¼ inch of the ½ or ¾ inch threshold may be vertical; the rest must be beveled.</p>	<p><input type="checkbox"/> Yes <input type="checkbox"/> No</p>	<p>Measurement: N/A</p>	 <p>3/4" max</p>	<p>Photo #:</p>

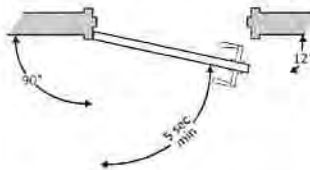
<p>3.9 Is the door equipped with hardware that is operable with one hand and does not require tight grasping, pinching or twisting of the wrist? Door handle? Lock (if provided)? [404.2.7]</p>	<p><input type="checkbox"/> Yes <input type="checkbox"/> No NA <input type="checkbox"/> Yes <input type="checkbox"/> No NA <input type="checkbox"/> Yes <input type="checkbox"/> No NA</p>		<p>Photo #:</p>	<ul style="list-style-type: none"> • Replace inaccessible knob with lever, loop or push hardware • Add automatic door opener •
<p>3.10 Are the operable parts of the door hardware mounted no less than 34 inches and no greater than 48 inches above the floor? [404.2.7]</p>	<p><input type="checkbox"/> Yes <input type="checkbox"/> No Measurement: NA</p>		<p>Photo #:</p>	<ul style="list-style-type: none"> • Change hardware height • •
<p>3.11 Can the door be opened easily (5 pounds maximum force)? [404.2.9] Note: You can use a pressure gauge or fish scale to measure force. If you do not have one you will need to judge whether the door is easy to open.</p>	<p><input type="checkbox"/> Yes <input type="checkbox"/> No Measurement: NA</p>		<p>Photo #:</p>	<ul style="list-style-type: none"> • Adjust or replace closers • Install lighter doors • Install power-assisted or automatic door openers
<p>3.12 If the door has a closer, does it take at least 5 seconds to close from an open position of 90 degrees to a position of 12 degrees from the latch? [404.2.8.1]</p>	<p><input type="checkbox"/> Yes <input type="checkbox"/> No Measurement: NA</p>		<p>Photo #:</p>	<ul style="list-style-type: none"> • Adjust closer • •

<p>3.13 If there are two doors in a series, e.g. vestibule, is the distance between the doors at least 48 inches plus the width of the doors when swinging into the space? [404.2.6]</p>	<p><input type="checkbox"/> Yes <input type="checkbox"/> No Measurement: NA</p>		<p>Photo #:</p>	<ul style="list-style-type: none"> • Remove inner door • Change door swing •
<p>3.14 If there is a privacy wall and the door swings out, is there at least 24 inches of maneuvering clearance beyond the door latch side and 42 inches to the privacy wall? [404.2.4]</p>	<p><input type="checkbox"/> Yes <input type="checkbox"/> No Measurement: NA</p>		<p>Photo #:</p>	<ul style="list-style-type: none"> • Reconfigure space • •

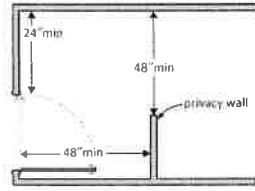
<p>3.15 If there is a privacy wall and the door swings in, is there at least 24 inches of maneuvering clearance beyond the door latch side and at least 48 inches to the privacy wall if there is no door closer or at least 54 inches if there is a door closer? [404.2.4]</p>	<p><input type="checkbox"/> Yes <input type="checkbox"/> No</p> <p>Measurement: <i>NA</i></p>		<p>Photo #:</p>	<ul style="list-style-type: none"> • Reconfigure space • •
----------------------------------------------------------------------------------------------------------------------------------------------------------------------------------------------------------------------------------------------------------------------------------------	---------------------------------------------------------------------------------------------------	-----------------------------------------------------------------------------------	-----------------	---------------------------------------------------------------------------------------------

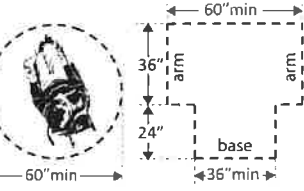
In the Toilet Room				
<p>3.16 Is there a clear path to at least one of each type of fixture, e.g. lavatory, hand dryer, etc., that is at least 36 inches wide? [403.5.1]</p>	<p><input type="checkbox"/> Yes <input type="checkbox"/> No</p> <p>Measurement: <i>NA</i></p>		<p>Photo #:</p>	<ul style="list-style-type: none"> • Remove obstructions • •
<p>3.17 Is there clear floor space available for a person in a wheelchair to turn around, i.e. a circle at least 60 inches in diameter or a T-shaped space within a 60-inch square? [603.2.1]</p>	<p><input type="checkbox"/> Yes <input type="checkbox"/> No</p> <p>Measurement: <i>NA</i></p>		<p>Photo #:</p>	<ul style="list-style-type: none"> • Move or remove partitions, fixtures or objects such as trash cans • •

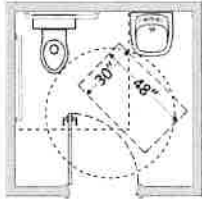
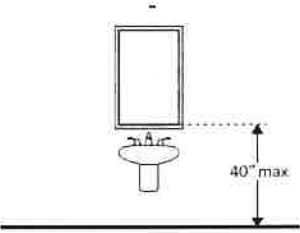
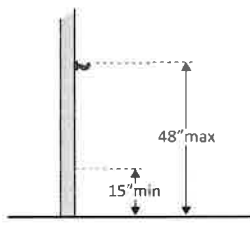
<p>3.18 In a single user toilet room if the door swings in and over a clear floor space at an accessible fixture, is there a clear floor space at least 30 x 48 inches beyond the swing of the door? [603.2.3 Exception 2]</p>	<p><input type="checkbox"/> Yes <input type="checkbox"/> No Measurement: N/A</p>		<p>Photo #:</p>	<ul style="list-style-type: none"> • Reverse door swing • Alter toilet room •
<p>3.19 If the mirror is over a lavatory or countertop, is the bottom edge of the reflecting surface no higher than 40 inches above the floor? Or If the mirror is not over the lavatory or countertop, is the bottom edge of the reflecting surface no higher than 35 inches above the floor?*[603.3]</p>	<p><input type="checkbox"/> Yes <input type="checkbox"/> No Measurement: N/A <input type="checkbox"/> Yes <input type="checkbox"/> No Measurement: N/A</p>		<p>Photo #:</p>	<ul style="list-style-type: none"> * If installed before 3/15/2012 and the bottom edge of the reflecting surface is no higher than 40 inches above the floor, lowering the mirror to 35 inches is not required • Lower the mirror • Add another mirror •
<p>3.20 If there is a coat hook, is it no less than 15 inches and no greater than 48 inches above the floor?*[603.4]</p>	<p><input type="checkbox"/> Yes <input type="checkbox"/> No Measurement: N/A</p>		<p>Photo #:</p>	<ul style="list-style-type: none"> • Adjust hook • Replace with or provide additional accessible hook • * If installed before 3/15/2010 and the clear floor space allows a parallel approach, the coat hook may be 54 inches above the floor.

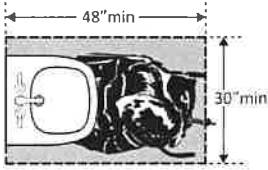
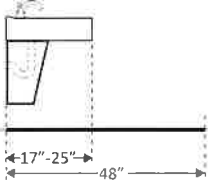
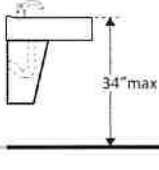
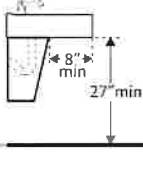
Lavatories The 2010 Standards refer to sinks in toilet rooms as lavatories.				
<p>3.21 Does at least one lavatory have a clear floor space for a forward approach at least 30 inches wide and 48 inches long? [606.2]</p>	<p><input type="checkbox"/> Yes <input type="checkbox"/> No Measurement: NA</p>		<p>Photo #:</p>	<ul style="list-style-type: none"> • Alter lavatory • Replace lavatory
<p>3.22 Do no less than 17 inches and no greater than 25 inches of the clear floor space extend under the lavatory so that a person using a wheelchair can get close enough to reach the faucet? [306.2]</p>	<p><input type="checkbox"/> Yes <input type="checkbox"/> No Measurement: NA</p>		<p>Photo #:</p>	<ul style="list-style-type: none"> • Alter lavatory • Replace lavatory
<p>3.23 Is the front of the lavatory or counter surface, whichever is higher, no more than 34 inches above the floor? [606.3]</p>	<p><input type="checkbox"/> Yes <input type="checkbox"/> No Measurement: NA</p>		<p>Photo #:</p>	<ul style="list-style-type: none"> • Alter lavatory • Replace lavatory
<p>3.24 Is there at least 27 inches clearance from the floor to the bottom of the lavatory that extends at least 8 inches under the lavatory for knee clearance? [306.3.3]</p>	<p><input type="checkbox"/> Yes <input type="checkbox"/> No Measurement: NA</p>		<p>Photo #:</p>	<ul style="list-style-type: none"> • Alter lavatory • Replace lavatory

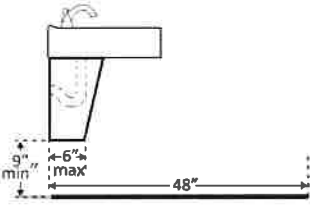
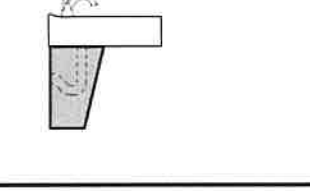
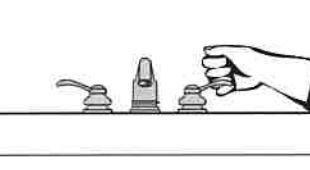
<p>3.25 Is there toe clearance at least 9 inches high? [306.3.3]</p> <p>Note: Space extending greater than 6 inches beyond the available toe clearance at 9 inches above the floor is not considered toe clearance.</p>	<p><input type="checkbox"/> Yes <input type="checkbox"/> No <i>NA</i></p>		<p>Photo #:</p>	<ul style="list-style-type: none"> • Alter lavatory • Replace lavatory •
<p>3.26 Are pipes below the lavatory insulated or otherwise configured to protect against contact? [606.5]</p>	<p><input type="checkbox"/> Yes <input type="checkbox"/> No <i>NA</i></p>		<p>Photo #:</p>	<ul style="list-style-type: none"> • Install insulation • Install cover panel •
<p>3.27 Can the faucet be operated without tight grasping, pinching, or twisting of the wrist?</p> <p>Is the force required to activate the faucet no greater than 5 pounds? [606.4]</p>	<p><input type="checkbox"/> Yes <input type="checkbox"/> No <i>NA</i></p> <p><input type="checkbox"/> Yes <input type="checkbox"/> No <i>NA</i></p>		<p>Photo #:</p>	<ul style="list-style-type: none"> • Adjust faucet • Replace faucet •

Soap Dispensers and Hand Dryers

ADA Checklist for Existing Facilities

Priority 3 – Toilet Rooms

3.28 Are the operable parts of the soap dispenser within one of the following reach ranges:

Above lavatories or counters no less than 20 inches and no greater than 25 inches deep: no higher than 44 inches above the floor?
[308.2.2]

Yes No

Measurement:

NA

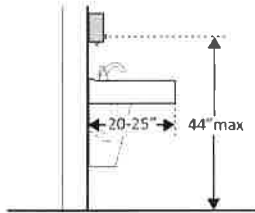

Above lavatories less than 20 inches deep: no higher than 48 inches above the floor?

Yes No

Measurement:

NA

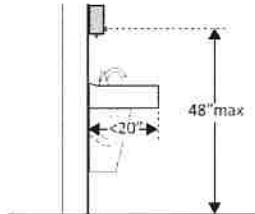

Not over an obstruction: no higher than 48 inches above the floor?
[308.2]

Yes No

Measurement:

NA

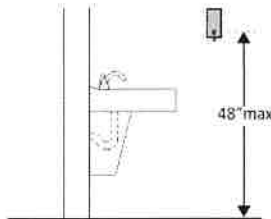

- Adjust dispensers
- Replace with or provide additional accessible dispensers
-

Photo #:

<p>3.29 Are the operable parts of the hand dryer or towel dispenser within one of the following reach ranges:</p> <p>Above lavatories or counters no less than 20 inches and no greater than 25 inches deep: no higher than 44 inches above the floor?</p> <p>Above lavatories less than 20 inches deep: no higher than 48 inches above the floor?</p> <p>Not over an obstruction: no higher than 48 inches above the floor? [308.2]</p> <p>Can the operable parts of the hand dryer or towel dispenser be operated without tight grasping, pinching or twisting of the wrist?</p> <p>Is the force required to activate the hand dryer or towel dispenser no greater than 5 pounds? [309.4]</p>	<p><input type="checkbox"/> Yes <input type="checkbox"/> No Measurement: <i>N/A</i></p> <p><input type="checkbox"/> Yes <input type="checkbox"/> No Measurement: <i>N/A</i></p> <p><input type="checkbox"/> Yes <input type="checkbox"/> No Measurement: <i>N/A</i></p> <p><input type="checkbox"/> Yes <input type="checkbox"/> No Measurement: <i>N/A</i></p> <p><input type="checkbox"/> Yes <input type="checkbox"/> No Measurement: <i>N/A</i></p>		<p>Photo #:</p>	<ul style="list-style-type: none"> • Adjust dispensers • Replace with or provide additional accessible dispensers
--------------------------------------------------------------------------------------------------------------------------------------------------------------------------------------------------------------------------------------------------------------------------------------------------------------------------------------------------------------------------------------------------------------------------------------------------------------------------------------------------------------------------------------------------------------------------------------------------------------------------------------------------------------------------------------------------------	-----------------------------------------------------------------------------------------------------------------------------------------------------------------------------------------------------------------------------------------------------------------------------------------------------------------------------------------------------------------------------------------------------------------------------------------------------------------------------	--	-----------------	-------------------------------------------------------------------------------------------------------------------------------------------

Water Closets in Single-User Toilet Rooms and Compartments (Stalls) The 2010 Standards refer to toilets as water closets.

ADA Checklist for Existing Facilities

Priority 3 – Toilet Rooms

3.30 Is the centerline of the water closet no less than 16 inches and no greater than 18 inches from the side wall or partition? [604.2]

Yes No
 Measurement:
 NA

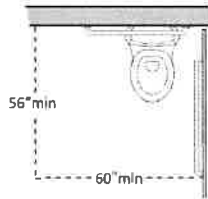

Photo #:

- Move toilet
- Replace toilet
- Move partition
-

3.31 Is clearance provided around the water closet measuring at least 60 inches from the side wall and at least 56 inches from the rear wall?*[604.3.1]

Yes No
 Measurement:
 NA



* If constructed before 3/15/12, clearances around water closets in single user toilet rooms can be 48 inches wide by 66 inches long or 48 inches wide by 56 inches long (depending on the approach to the water closet, see 1991 Standards Figure 28) and the lavatory may overlap that clearance if the door to the room does not swing into the required clearances at fixtures (such as lavatories, water closet and urinals) and the edge of the lavatory is at least 18 inches from the centerline of the water closet

- Alter room/compartment for clearance
-
-

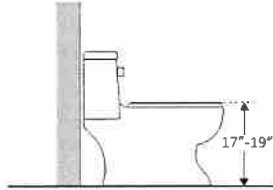
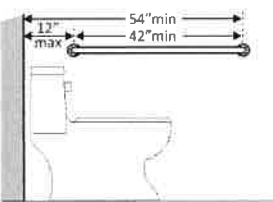
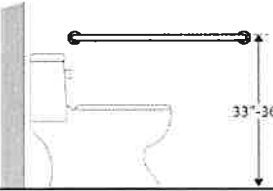
			Photo #:	
<p>3.32 Is the height of the water closet no less than 17 inches and no greater than 19 inches above the floor measured to the top of the seat? [604.4]</p>	<p><input type="checkbox"/> Yes <input type="checkbox"/> No Measurement: <i>NA</i></p>		Photo #:	<ul style="list-style-type: none"> • Adjust toilet height • Replace toilet •
<p>3.33 Is there a grab bar at least 42 inches long on the side wall?</p> <p>Is it located no more than 12 inches from the rear wall?</p> <p>Does it extend at least 54 inches from the rear wall? [604.5.1]</p> <p>Is it mounted no less than 33 inches and no greater than 36 inches above the floor to the top of the gripping surface? [609.4]</p> <p>Is there at least 12 inches clearance between the grab bar</p>	<p><input type="checkbox"/> Yes <input type="checkbox"/> No Measurement: <i>NA</i></p> <p><input type="checkbox"/> Yes <input type="checkbox"/> No Measurement: <i>NA</i></p> <p><input type="checkbox"/> Yes <input type="checkbox"/> No Measurement: <i>NA</i></p> <p><input type="checkbox"/> Yes <input type="checkbox"/> No Measurement: <i>NA</i></p> <p><input type="checkbox"/> Yes <input type="checkbox"/> No Measurement: <i>NA</i></p>	 		<ul style="list-style-type: none"> • Install grab bar • Relocate grab bar • Relocate objects •

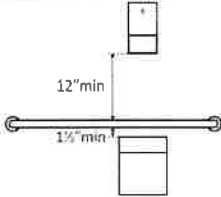
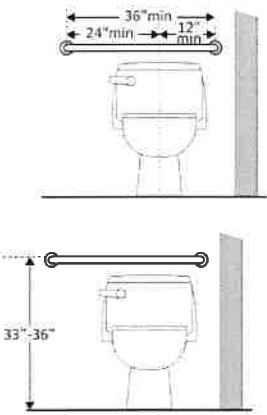
<p>and protruding objects above?*</p> <p>Is there at least 1½ inches clearance between the grab bar and projecting objects below?*</p> <p>Is the space between the wall and the grab bar 1 ½ inches? [609.3]</p>	<p>Measurement:</p> <p><input type="checkbox"/> Yes <input type="checkbox"/> No</p> <p>Measurement: <i>NA</i></p> <p><input type="checkbox"/> Yes <input type="checkbox"/> No</p> <p>Measurement: <i>NA</i></p>		<p>Photo #:</p>	<p>* If constructed before 3/15/2012 grab bars do not need to be relocated; there are no space requirements above and below grab bars in the 1991 Standards</p>
<p>3.34 Is there a grab bar at least 36 inches long on the rear wall?</p> <p>Does it extend at least 12 inches from the centerline of the water closet on one side (side wall)?</p> <p>Does it extend at least 24 inches on the other (open) side? [604.5.2]</p> <p>Is it mounted no less than 33 inches and no greater than 36 inches above the floor to the top of the gripping surface? [609.4]</p> <p>Are there at least 12 inches clearance between the grab bar and protruding objects above?*</p> <p>Are there at least 1½ inches</p>	<p><input type="checkbox"/> Yes <input type="checkbox"/> No</p> <p>Measurement: <i>NA</i></p> <p><input type="checkbox"/> Yes <input type="checkbox"/> No</p> <p>Measurement: <i>NA</i></p> <p><input type="checkbox"/> Yes <input type="checkbox"/> No</p> <p>Measurement: <i>NA</i></p> <p><input type="checkbox"/> Yes <input type="checkbox"/> No</p> <p>Measurement: <i>NA</i></p> <p><input type="checkbox"/> Yes <input type="checkbox"/> No</p> <p>Measurement: <i>NA</i></p> <p><input type="checkbox"/> Yes <input type="checkbox"/> No</p> <p>Measurement: <i>NA</i></p>		<p>Photo #:</p>	<ul style="list-style-type: none"> • Install grab bar • Relocate grab bar • Relocate objects • <p>* If constructed before 3/15/2012 grab bars do not need to be relocated; there are no space</p>

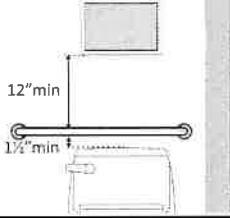
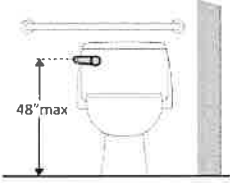
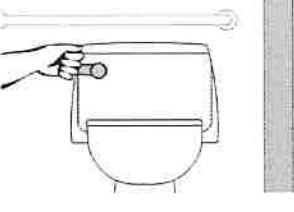
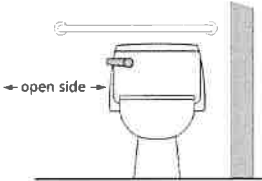
<p>clearance between the grab bar and projecting objects below?*</p> <p>Is the space between the wall and the grab bar 1½ inches? [609.3]</p>	<p>Measurement:</p> <p><input type="checkbox"/> Yes <input type="checkbox"/> No</p> <p>Measurement: <i>NA</i></p>		<p>Photo #:</p>	<p>requirements above and below grab bars in the 1991 Standards</p>
<p>3.35 If the flush control is hand operated, is the operable part located no higher than 48 inches above the floor? [604.6]</p>	<p><input type="checkbox"/> Yes <input type="checkbox"/> No</p> <p>Measurement: <i>NA</i></p>		<p>Photo #:</p>	<ul style="list-style-type: none"> • Move control • Install sensor with override button no higher than 48 inches •
<p>3.36 If the flush control is hand operated, can it be operated with one hand and without tight grasping, pinching, or twisting of the wrist?</p> <p>Is the force required to activate the flush control no greater than 5 pounds? [605.4]</p>	<p><input type="checkbox"/> Yes <input type="checkbox"/> No <i>NA</i></p> <p><input type="checkbox"/> Yes <input type="checkbox"/> No</p> <p>Measurement: <i>NA</i></p>		<p>Photo #:</p>	<ul style="list-style-type: none"> • Change control • Adjust control •
<p>3.37 Is the flush control on the open side of the water closet? [604.6]</p>	<p><input type="checkbox"/> Yes <input type="checkbox"/> No <i>NA</i></p>		<p>Photo #:</p>	<ul style="list-style-type: none"> • Move control • •

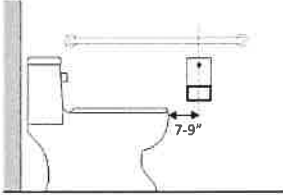
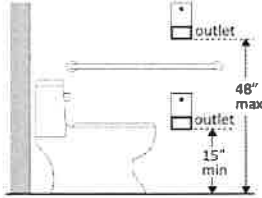
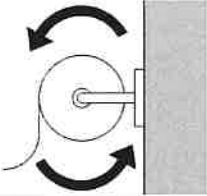
<p>3.38 Is the toilet paper dispenser located no less than 7 inches and no greater than 9 inches from the front of the water closet to the centerline of the dispenser?*</p> <p>[604.7]</p>	<p><input type="checkbox"/> Yes <input type="checkbox"/> No</p> <p>Measurement: N/A</p>		<p>Photo #:</p> <p>* If constructed before 3/15/2012 dispenser does not need to be relocated if it is within reach from the water closet seat; the 1991 Standards do not specify distance from the front of the water closet</p> <ul style="list-style-type: none"> • Relocate dispenser • •
<p>3.39 Is the outlet of the dispenser:</p> <p>Located no less than 15 inches and no greater than 48 inches above the floor?</p> <p>Not located behind grab bars?</p> <p>[604.7]</p>	<p><input type="checkbox"/> Yes <input type="checkbox"/> No</p> <p>Measurement: N/A</p> <p><input type="checkbox"/> Yes <input type="checkbox"/> No</p> <p>N/A</p>		<p>Photo #:</p> <ul style="list-style-type: none"> • Relocate dispenser • •
<p>3.40 Does the dispenser allow continuous paper flow?</p> <p>[604.7]</p>	<p><input type="checkbox"/> Yes <input type="checkbox"/> No</p> <p>N/A</p>		<p>Photo #:</p> <ul style="list-style-type: none"> • Adjust dispenser • Replace dispenser •

Toilet Compartments (Stalls)

ADA Checklist for Existing Facilities

Priority 3 – Toilet Rooms

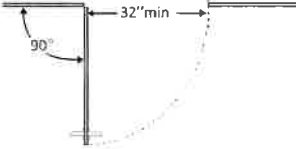
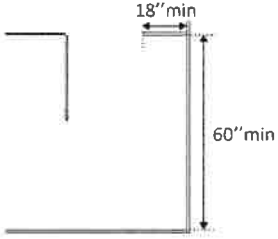
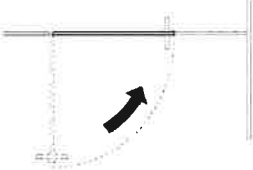
<p>3.41 Is the door opening width at least 32 inches clear, between the face of the door and the stop, when the door is open 90 degrees? [604.8.1.2]</p>	<p><input type="checkbox"/> Yes <input type="checkbox"/> No Measurement: NA</p>		<p>Photo #:</p>	<ul style="list-style-type: none"> • Widen door width • •
<p>3.42 If there is a front approach to the pull side of the door, is there at least 18 inches of maneuvering clearance beyond the latch side plus 60 inches clear depth? [604.8.1.2]</p> <p>Note: See 2010 Standards 604.8.1.2 Doors for maneuvering clearance requirements on the push side of the door and side approaches to the pull side of the door</p>	<p><input type="checkbox"/> Yes <input type="checkbox"/> No Measurement: NA</p>		<p>Photo #:</p>	<ul style="list-style-type: none"> • Remove obstructions • •
<p>3.43 Is the door self-closing? [604.8.1.2]</p>	<p><input type="checkbox"/> Yes <input type="checkbox"/> No NA</p>		<p>Photo #:</p>	<ul style="list-style-type: none"> • Add closer • Replace door •

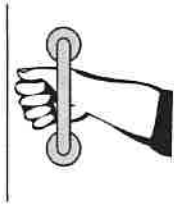
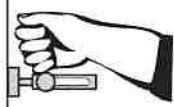
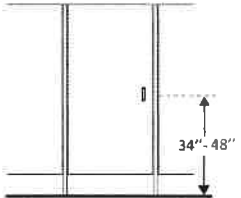
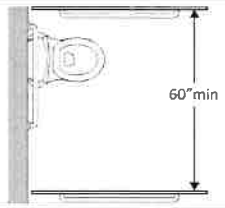
<p>3.44 Are there door pulls on both sides of the door that are operable with one hand and do not require tight grasping pinching or twisting of the wrist?*</p> <p>[604.8.1.2]</p>	<p><input type="checkbox"/> Yes <input type="checkbox"/> No</p> <p>NA</p>		<p>Photo #:</p>	<p>* If constructed before 3/15/2012 door pulls do not need to be added; door pulls are not required in the 1991 Standards</p> <ul style="list-style-type: none"> • Replace hardware • •
<p>3.45 Is the lock operable with one hand and without tight grasping, pinching or twisting of the wrist?</p> <p>[309.4]</p>	<p><input type="checkbox"/> Yes <input type="checkbox"/> No</p> <p>NA</p>		<p>Photo #:</p>	<ul style="list-style-type: none"> • Replace lock • •
<p>3.46 Are the operable parts of the door hardware mounted no less than 34 inches and no greater than 48 inches above the floor?</p> <p>[404.2.7]</p>	<p><input type="checkbox"/> Yes <input type="checkbox"/> No</p> <p>Measurement:</p> <p>NA</p>		<p>Photo #:</p>	<ul style="list-style-type: none"> • Relocate hardware • •
<p>3.47 Is the compartment at least 60 inches wide?</p> <p>[604.8.1.1]</p>	<p><input type="checkbox"/> Yes <input type="checkbox"/> No</p> <p>Measurement:</p> <p>NA</p>		<p>Photo #:</p>	<ul style="list-style-type: none"> • Widen compartment • •

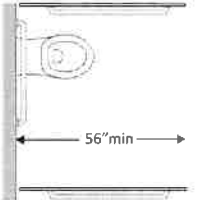
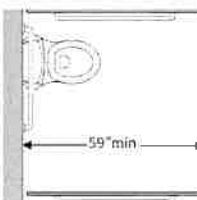
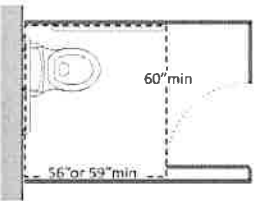
<p>3.48 If the water closet is wall hung, is the compartment at least 56 inches deep? [604.8.1.1]</p>	<p><input type="checkbox"/> Yes <input type="checkbox"/> No Measurement: <i>NA</i></p>		<p>Photo #:</p>	<ul style="list-style-type: none"> • Widen compartment • •
<p>3.49 If the water closet is floor mounted, is the compartment at least 59 inches deep? [604.8.1.1]</p>	<p><input type="checkbox"/> Yes <input type="checkbox"/> No Measurement: <i>NA</i></p>		<p>Photo #:</p>	<ul style="list-style-type: none"> • Alter compartment • •
<p>3.50 If the door swings in, is the minimum required compartment area provided beyond the swing of the door (60 inches x 56 inches if water closet is wall hung or 59 inches if water closet is floor mounted)? [604.8.1.1]</p>	<p><input type="checkbox"/> Yes <input type="checkbox"/> No Measurement: <i>NA</i></p>		<p>Photo #:</p>	<ul style="list-style-type: none"> • Reverse door swing • Alter compartment •

ADA Checklist for Existing Facilities

Priority 4 – Additional Access

Based on the 2010 ADA Standards for Accessible Design

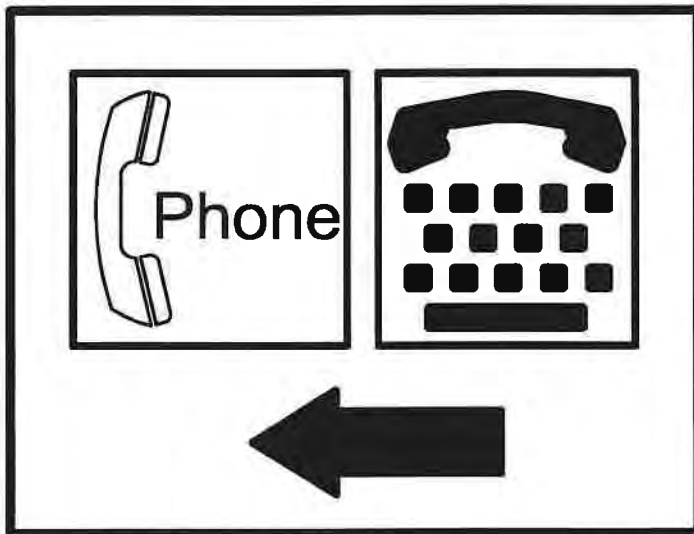

Project ADA TRANSITIONAL PHASE

Building WATER TREATMENT PLANT

Location WEAVERVILLE NC.

Date 4-21-2020

Surveyors ALAN F. MACKAY

Contact Information TRENT DUNCAN

Amenities such as drinking fountains and public telephones should be accessible to people with disabilities.



Institute for Human Centered Design
www.HumanCenteredDesign.org
Copyright © 2016



ADA National Network
Questions on the ADA 800-949-4232 voice/tty
www.ADAchecklist.org





This checklist was produced by the New England ADA Center, a project of the Institute for Human Centered Design and a member of the ADA National Network. This checklist was developed under a grant from the Department of Education, NIDRR grant number H133A060092-09A. However the contents do not necessarily represent the policy of the Department of Education, and you should not assume endorsement by the Federal Government.

Questions or comments on the checklist contact the New England ADA Center at 617-695-0085 voice/tty or ADAinfo@NewEnglandADA.org

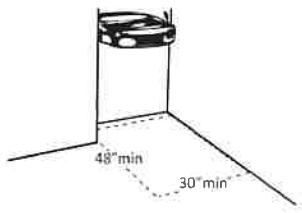
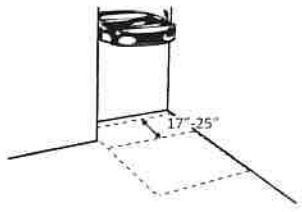
For the full set of checklists, including the checklists for recreation facilities visit www.ADAchecklist.org.

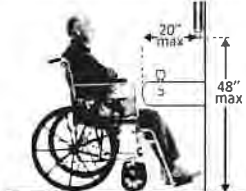



Copyright © 2016 ADA Checklist for Existing Materials. You can freely reproduce and distribute this content. Include proper attribution. But you must get permission before using this content as a fee-based product.

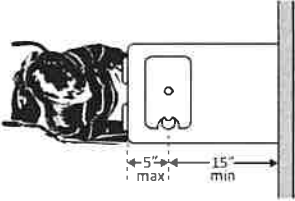
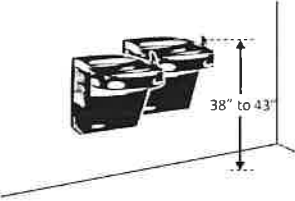
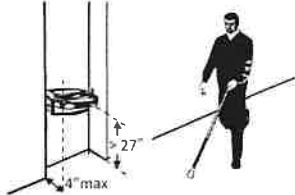

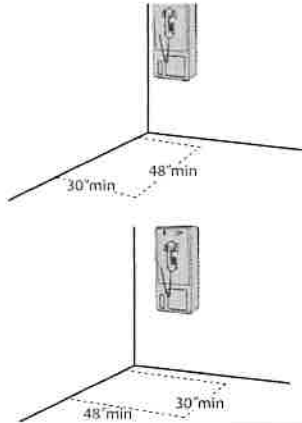
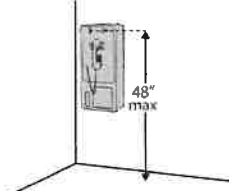
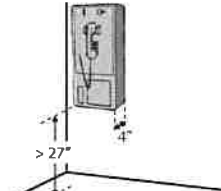
Priority 4 – Additional Access		Comments	Possible Solutions
Drinking Fountains			
<p>4.1 Does at least one drinking fountain have a clear floor space at least 30 inches wide x at least 48 inches long centered in front of it for a forward approach?*</p> <p>[See 2010 ADA Standards for Accessible Design – 602.2]</p>	<p><input type="checkbox"/> Yes <input type="checkbox"/> No</p> <p>Measurement: NA</p>	 <p>48" min 30" min</p> <p>Photo #:</p>	<p>*If installed before 3/15/2012, a parallel approach is permitted and the clear floor space is not required to be centered</p> <ul style="list-style-type: none"> • Alter space • Relocate drinking fountain • Install a drinking fountain in another location
<p>4.2 If there is a forward approach, do no less than 17 inches and no greater than 25 inches of the clear floor space extend under the drinking fountain?</p> <p>[306.2.2, 306.2.3]</p> <p>Note: If the drinking fountain is primarily for children's use and the spout is no more than 30 inches above the floor and no more than 3 1/2 inches from the edge of the unit, a parallel approach is permitted.</p>	<p><input type="checkbox"/> Yes <input type="checkbox"/> No</p> <p>Measurement: NA</p>	 <p>17" - 25"</p> <p>Photo #:</p>	<ul style="list-style-type: none"> • Alter space • Replace drinking fountain •

<p>4.3 If the drinking fountain is no deeper than 20 inches, are the operable parts no higher than 48 inches above the floor? [308.2.2]</p>	<p><input type="checkbox"/> Yes <input type="checkbox"/> No Measurement: NA</p>		<p>Photo #:</p>	<ul style="list-style-type: none"> • Adjust drinking fountain • Replace drinking fountain
<p>4.4 If the drinking fountain is no less than 20 inches and no greater than 25 inches deep, are the operable parts no higher than 44 inches above the floor? [308.2.2]</p>	<p><input type="checkbox"/> Yes <input type="checkbox"/> No Measurement: NA</p>		<p>Photo #:</p>	<ul style="list-style-type: none"> • Adjust drinking fountain • Replace drinking fountain
<p>4.5 Can the control be operated with one hand and without tight grasping, pinching or twisting of the wrist? Is the force required to activate the control no more than 5 pounds? [309.4]</p>	<p><input type="checkbox"/> Yes <input type="checkbox"/> No NA <input type="checkbox"/> Yes <input type="checkbox"/> No Measurement: NA</p>		<p>Photo #:</p>	<ul style="list-style-type: none"> • Change control • Adjust control
<p>4.6 Is the spout outlet no higher than 36 inches above the floor? [602.4]</p>	<p><input type="checkbox"/> Yes <input type="checkbox"/> No Measurement: NA</p>		<p>Photo #:</p>	<ul style="list-style-type: none"> • Adjust drinking fountain • Replace drinking fountain

<p>4.7 Is the spout:</p> <p>At least 15 inches from the rear of the drinking fountain?</p> <p>No more than 5 inches from the front of the drinking fountain? [602.5]</p>	<p><input type="checkbox"/> Yes <input type="checkbox"/> No</p> <p>Measurement: <i>NA</i></p> <p><input type="checkbox"/> Yes <input type="checkbox"/> No</p> <p>Measurement: <i>NA</i></p>		<p>Photo #:</p>	<ul style="list-style-type: none"> • Adjust spout • Replace drinking fountain •
<p>4.8 If there is more than one drinking fountain, is there at least one for standing persons? [211.2]</p> <p>Is the spout outlet no lower than 38 inches and no higher than 43 inches above the floor? [602.7]</p>	<p><input type="checkbox"/> Yes <input type="checkbox"/> No</p> <p>Measurement: <i>NA</i></p> <p><input type="checkbox"/> Yes <input type="checkbox"/> No</p> <p>Measurement: <i>NA</i></p>		<p>Photo #:</p>	<ul style="list-style-type: none"> • Adjust drinking fountain • Install new drinking fountain for standing height •
<p>4.9 If the leading (bottom) edge of the fountain is higher than 27 inches above the floor, does the front of the fountain protrude no more than 4 inches into the circulation path? [307.2]</p>	<p><input type="checkbox"/> Yes <input type="checkbox"/> No</p> <p>Measurement: <i>NA</i></p>		<p>Photo #:</p>	<ul style="list-style-type: none"> • Adjust drinking fountain • Replace drinking fountain • Add tactile warning such as permanent planter or partial walls

Public Telephones				
<p>4.10 Does at least one telephone have a clear floor space at least 30 inches wide x at least 48 inches long for a parallel or forward approach? [704.2.1]</p>	<p><input type="checkbox"/> Yes <input type="checkbox"/> No</p> <p>NA</p>		<p>Photo #:</p>	<ul style="list-style-type: none"> • Move telephone • Install new telephone for clear floor space
<p>4.11 Is the highest operable part of the telephone no higher than 48 inches above the floor? [704.2.2]</p>	<p><input type="checkbox"/> Yes <input type="checkbox"/> No</p> <p>Measurement:</p> <p>NA</p>		<p>Photo #:</p>	<ul style="list-style-type: none"> • Adjust telephone
<p>4.12 If the leading (bottom) edge of the telephone is higher than 27 inches above the floor, does the front of the telephone protrude no more than 4 inches into the circulation path? [307.2]</p>	<p><input type="checkbox"/> Yes <input type="checkbox"/> No</p> <p>Measurement:</p> <p>NA</p>		<p>Photo #:</p>	<ul style="list-style-type: none"> • Adjust telephone

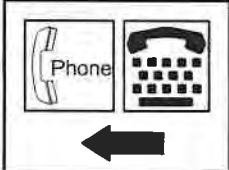
<p>4.13 Does at least one telephone have a volume control? [704.3]</p>	<p><input type="checkbox"/> Yes <input type="checkbox"/> No</p> <p>NA</p>		<p>Photo #:</p>	<ul style="list-style-type: none"> • Install volume control • Replace telephone with one that has volume control •
<p>4.14 Is the volume control identified by a pictogram of a telephone handset with radiating sound waves? [703.7.2.3]</p>	<p><input type="checkbox"/> Yes <input type="checkbox"/> No</p> <p>NA</p>		<p>Photo #:</p>	<ul style="list-style-type: none"> • Add pictogram • •
<p>4.15 Does at least one telephone have a TTY? [217.4.1]</p> <p>Note: TTY's are devices that employ interactive text-based communication through the transmission of coded signals across the telephone network. They are mainly used by people who are deaf and/or cannot speak.</p>	<p><input type="checkbox"/> Yes <input type="checkbox"/> No</p> <p>NA</p>		<p>Photo #:</p>	<ul style="list-style-type: none"> • Install TTY • •
<p>4.16 Is the touch surface of the TTY keypad at least 34 inches above the floor? [704.4.1]</p> <p>Note: If a seat is provided, the TTY is not required to be 34 inches minimum above the floor.</p>	<p><input type="checkbox"/> Yes <input type="checkbox"/> No</p> <p>Measurement:</p> <p>NA</p>		<p>Photo #:</p>	<ul style="list-style-type: none"> • Adjust height of TTY • •

<p>4.17 Is the TTY identified by the International Symbol of TTY? [703.7.2.2]</p>	<p><input type="checkbox"/> Yes <input type="checkbox"/> No</p> <p>NA</p>		<p>Photo #:</p>	<ul style="list-style-type: none"> • Add symbol • •
<p>4.18 Do signs that provide direction to public telephones also provide direction to the TTY? [216.9.2]</p>	<p><input type="checkbox"/> Yes <input type="checkbox"/> No</p> <p>NA</p>		<p>Photo #:</p>	<ul style="list-style-type: none"> • Add signs • •
<p>4.19 Do telephones that do not have a TTY provide direction to the TTY? [216.9.2]</p>	<p><input type="checkbox"/> Yes <input type="checkbox"/> No</p> <p>NA</p>		<p>Photo #:</p>	<ul style="list-style-type: none"> • Add signs • •
<p>Fire Alarm Systems</p>				
<p>4.20 If there are fire alarm systems, do they have both flashing lights and audible signals? [702.1]</p>	<p><input type="checkbox"/> Yes <input type="checkbox"/> No</p> <p>NA</p>		<p>Photo #:</p>	<ul style="list-style-type: none"> • Install audible and visual alarms • •



TOWN OF WEAVERVILLE

APPENDIX C.5:

Lake Louise Playground

ADA TRANSITION PLAN

ADA Checklist for Existing Facilities

Play Areas

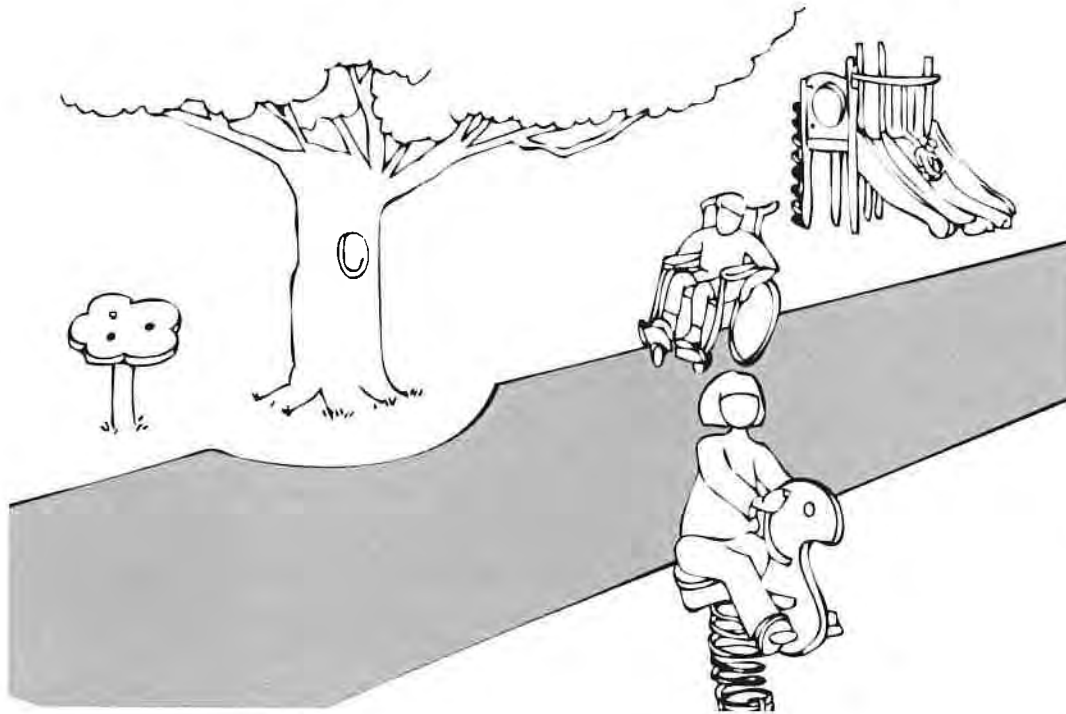

Project ADA TRANSITION PLAN

Building LAKE LOUISE PLAYGROUNDS

Location TOWN OF WEAVERVILLE N.C.

Date 5-7-2020

Surveyors ALAN F. MACKAY

Contact Information DALE PERELL

Play areas should be accessible to everyone, including people with disabilities.



Institute for Human Centered Design
www.HumanCenteredDesign.org

Copyright © 2016



ADA National Network
Questions on the ADA 800-949-4232 voice/tty
www.ADAchecklist.org

This checklist was produced by the New England ADA Center, a project of the Institute for Human Centered Design and a member of the ADA National Network. This checklist was developed under a grant from the Department of Education, NIDRR grant number H133A060092-09A. However the contents do not necessarily represent the policy of the Department of Education, and you should not assume endorsement by the Federal Government.

Questions or comments on the checklist contact the New England ADA Center at 617-695-0085 voice/tty or ADAinfo@NewEnglandADA.org

For the full set of checklists, including the checklists for recreation facilities visit www.ADAchecklist.org.

Copyright © 2016 ADA Checklist for Existing Materials. You can freely reproduce and distribute this content. Include proper attribution. But you must get permission before using this content as a fee-based product.

Play Areas		Comments	Possible Solutions
<p>Play Areas (2010 Standards – 206, 240 & 1008) Note: Play areas for children under age 2 and play areas in family child care facilities where the proprietor resides do not have to comply.</p>			
<p>P1 Is there an accessible route to the entrance of the play area?</p> <p>If there are separate play areas within a site for specific age groups, is there an accessible route to each play area?</p> <p>Is there an accessible route within the play area connecting ground level play components that are on an accessible route and elevated play components that are on an accessible route including the entry and exit points of those components?</p> <p>Use the checklist for <i>Priority 1: Approach & Entrance</i></p>	<p><input checked="" type="checkbox"/> Yes <input type="checkbox"/> No</p> <p><input type="checkbox"/> Yes <input checked="" type="checkbox"/> No</p> <p><input type="checkbox"/> Yes <input checked="" type="checkbox"/> No</p>	<p>Photo #:</p>	<ul style="list-style-type: none"> • • •
<p>P2 <u>Ground Level Play Components</u> Is there an accessible route to at least one of each type of ground level play component?</p> <p>Notes: 1. A play component is an element designed to generate play, socialization and learning. In the 2010 Standards ramps, transfer systems, steps, decks and roofs are not considered play components.</p>	<p><input type="checkbox"/> Yes <input checked="" type="checkbox"/> No</p>		<ul style="list-style-type: none"> • • •

2. Ground level play components are components that can be approached and exited at ground level. Examples include rockers, swings, diggers, and stand-alone slides. When distinguishing between types of components consider the experience provided. Examples include rocking, swinging, climbing, digging, spinning and sliding.

Photo #:

P3 If there are elevated play components, is there an accessible route to at least the following number and type of ground level play components? See chart below.

Yes No

-
-
-

Notes:

1. The intent is to provide a variety of experiences for children who want to remain in their wheelchair or with another mobility device and who choose not to transfer to elevated components.

2. If a play area includes two or more composite structures for the same age group, use the total number of elevated components to determine the additional number and types of ground level play components

to provide on an accessible route.
 3. If ramps provide access to at least 50 percent of the elevated components and the ramped route goes to at least three different elevated play types, the ground level components in the chart are not required.
 4. The number of ground level components determined by "one of each type" can fulfill the minimum ground level requirements in the table.

Photo #:

Number of Elevated Play Components Provided	Minimum Number of Ground Level Play Components Required to be on an Accessible Route	Minimum Number of Different Types of Ground Level Play Components Required to be on an Accessible Route
1	n/a	n/a
2 to 4	1	1
5 to 7	2	2
8 to 10	3	3
11 to 13	4	3
14 to 16	5	3
17 to 19	6	3
20 to 22	7	4
23 to 25	8	4
26 and over	8, plus 1 for each additional 3, or fraction thereof, over 25	5

P4 If two or more ground level play components are on an accessible route are they dispersed throughout the play area and integrated with other play components?

Yes No

•
•
•

Photo #:

ADA Checklist for Existing Facilities

Play Areas

<p>P5 If there is a soft contained play structure with three or fewer entry point, is there an accessible route to at least one entry point?</p> <p>If there are four or more entry points, are there accessible routes to at least two entry points?</p> <p>Notes: 1. A soft contained play area is a play structure made of one or more components on which a person enters a fully enclosed play environment that uses pliable materials such as plastic, soft padding and fabric.</p>	<p><input type="checkbox"/> Yes <input checked="" type="checkbox"/> No</p> <p><input type="checkbox"/> Yes <input type="checkbox"/> No N/A</p>	<p>ONE ENTRY POINT</p>	<p>Photo #:</p>	<ul style="list-style-type: none"> • • •
<p>P6 <u>Accessible Route Connecting Ground Level Play Components</u> Use the checklist for <i>Priority 1: Approach & Entrance</i> with the following exceptions and requirements.</p> <p>Note: If there is a water play component and the accessible route is submerged, it is not required to be slip resistant, the running slope may be steeper than 1:12 and the cross slope may be steeper than 1:48.</p>			<p>Photo #:</p>	<ul style="list-style-type: none"> • • •

<p>P7 Is the vertical clearance of the accessible route at least 80 inches above the ground surface?</p> <p>Note: Objects below 80 inches may not protrude into the accessible route.</p>	<p><input checked="" type="checkbox"/> Yes <input type="checkbox"/> No</p> <p>Measurement:</p>		<p>Photo #:</p>	<ul style="list-style-type: none"> • • •
<p>P8 If the play area is less than 1000 square feet: Is the route at least 44 inches wide?</p> <p>If the route exceeds 30 feet in length is a wheelchair turning space provided, i.e. a circle at least 60 inches in diameter or a T-shaped space within a 60-inch square?</p>	<p><input checked="" type="checkbox"/> Yes <input type="checkbox"/> No</p> <p>Measurement: N/A</p> <p><input type="checkbox"/> Yes <input type="checkbox"/> No</p> <p>Measurement: N/A</p>		<p>Photo #:</p>	<ul style="list-style-type: none"> • • •
<p>P9 If the play area is 1000 square feet or greater is the route at least: 60 inches wide or 36 inches wide for a distance no greater than 60 inches if reduced segments are separated by segments at least 60 wide and at least 60 inches long?</p> <p>Note: This permits flexibility around site features such as trees and equipment.</p>	<p><input checked="" type="checkbox"/> Yes <input type="checkbox"/> No</p> <p>Measurement: 64"</p> <p><input type="checkbox"/> Yes <input type="checkbox"/> No</p> <p>Measurement: N/A</p>		<p>Photo #:</p>	<ul style="list-style-type: none"> • • •

ADA Checklist for Existing Facilities

Play Areas

<p>P10 Is the route no steeper than 1:16, i.e. for every inch of height change there are at least 16 inches of run?</p>	<p><input checked="" type="checkbox"/> Yes <input type="checkbox"/> No</p> <p>Measurement: 1" - 1/2"</p>		<p>Photo #:</p>	<ul style="list-style-type: none"> • • •
<p>P11 If the route is steeper than 1:20 and the rise for a ramp run is higher than 6 inches are there handrails on both sides of the ramp run?</p> <p>Notes: 1. Handrail extensions are not required. 2. Handrails are not required on ramps within ground level use zones. The use zone is the area beneath and adjacent to a play structure upon which a user would land when falling from or exiting a play structure.</p>	<p><input checked="" type="checkbox"/> Yes <input type="checkbox"/> No</p>		<p>Photo #:</p>	<ul style="list-style-type: none"> • • •
<p>P12 Is the top of the handrail gripping surface no less than 20 inches and no greater than 28 inches above the ramp surface?</p>	<p><input type="checkbox"/> Yes <input checked="" type="checkbox"/> No</p> <p>Measurement: 36"</p>	<p style="border: 1px solid red; padding: 2px;">See P19 and P20 for Elevated Facility Rails</p>	<p>Photo #:</p>	<ul style="list-style-type: none"> • • •
<p>P13 Is the handrail gripping surface: Circular with an outside diameter of at least .95 inch and no more than 1.55 inches? or Non-circular providing an equivalent gripping surface?</p>	<p><input type="checkbox"/> Yes <input checked="" type="checkbox"/> No</p> <p>Measurement: 1.75"</p>		<p>Photo #:</p>	<ul style="list-style-type: none"> • • •

<p>P14 <u>Elevated Play Components</u> Is there an accessible route to entry and exit points of at least 50 percent of elevated components?</p> <p>Note: An elevated play component is a component approached above or below grade that is part of a structure of two or more play components providing more than one play activity.</p>	<p><input checked="" type="checkbox"/> Yes <input type="checkbox"/> No</p> <p>Measurement: NA</p>	<p>• ONE ENTRY POINT</p> <p>• EXIT POINTS BY SLIDES + LADDERS</p>	<p>Photo #:</p>	<p>•</p> <p>•</p> <p>•</p>
<p>P15 If there are 20 or more elevated play components are at least 25% connected by ramps?</p> <p>Are the other 25% that are required to be on an accessible route connected by either ramps or transfer systems?</p>	<p><input type="checkbox"/> Yes <input type="checkbox"/> No</p> <p>NA</p> <p><input type="checkbox"/> Yes <input type="checkbox"/> No</p> <p>NA</p>		<p>Photo #:</p>	<p>•</p> <p>•</p> <p>•</p>
<p>P16 If there are fewer than 20 elevated play components are at least 50% connected by either ramps or transfer systems.</p> <p>Note: Ramps are preferred but are not required.</p>	<p><input checked="" type="checkbox"/> Yes <input type="checkbox"/> No</p>		<p>Photo #:</p>	<p>•</p> <p>•</p> <p>•</p>
<p>P17 <u>Elevated Play Components Accessible Route</u> Use the checklist for <i>Priority 1: Approach & Entrance</i> and the following exceptions and requirements.</p>				<p>•</p> <p>•</p> <p>•</p>

<p>Is the accessible route connecting elevated play components: At least 36 inches wide? or At least 32 inches wide for a distance no greater than 24 inches if the reduced width segments are separated by segments at least 48 inches long and at least 36 inches wide? or If part of a transfer system, at least 24 inches wide?</p>	<p><input checked="" type="checkbox"/> Yes <input type="checkbox"/> No Measurement: 36" <input type="checkbox"/> Yes <input type="checkbox"/> No Measurement: NA <input type="checkbox"/> Yes <input type="checkbox"/> No Measurement:</p>		<p>Photo #:</p>	
<p>P18 If there is a ramp are there handrails on both sides? Note: Handrail extensions are not required.</p>	<p><input checked="" type="checkbox"/> Yes <input type="checkbox"/> No</p>		<p>Photo #:</p>	<ul style="list-style-type: none"> • • •
<p>P19 Is the top of the handrail gripping surface no less than 20 inches and no greater than 28 inches above the ramp surface?</p>	<p><input type="checkbox"/> Yes <input checked="" type="checkbox"/> No Measurement: 36"</p>	<p style="border: 1px solid red; padding: 5px; color: red;">Various handrail heights for all ages. No failure.</p>	<p>Photo #:</p>	<ul style="list-style-type: none"> • • •
<p>P20 If the handrail gripping surface is: Circular, is the outside diameter no less than .94 inch and no greater than 1.55 inch?</p>	<p><input type="checkbox"/> Yes <input checked="" type="checkbox"/> No Measurement: 1.75"</p>		<p>Photo #:</p>	<ul style="list-style-type: none"> • • •

	Non-circular, is it equivalent to a circular gripping surface with a diameter no less than .94 inch and no greater than 1.55 inch?	<input type="checkbox"/> Yes <input type="checkbox"/> No Measurement: <i>NA</i>			
P21	Is the rise for any ramp run connecting elevated play components no greater than 12 inches?	<input checked="" type="checkbox"/> Yes <input type="checkbox"/> No Measurement: <i>6"</i>			• • •
P22	If a transfer system is provided is the transfer system at least 24 inches wide?	<input type="checkbox"/> Yes <input type="checkbox"/> No Measurement: <i>36"</i>	N/A		• • •
P23	Is the top of the transfer platform no less than 11 inches and no greater than 18 inches from the ground?	<input type="checkbox"/> Yes <input type="checkbox"/> No Measurement: <i>48"</i>	N/A		• • •
P24	Is the transfer platform at least 14 inches deep by at least 24 inches wide?	<input type="checkbox"/> Yes <input type="checkbox"/> No Measurement: <i>NA</i>			• • •
P25	Is there a clear transfer space at least 30 inches wide by at least 48 inches long adjacent to the platform, with the longer dimension centered on and parallel to the 24 inch minimum long side of the platform?	<input type="checkbox"/> Yes <input type="checkbox"/> No Measurement: <i>NA</i>			• • •

<p>P26 Is the side of the transfer platform adjacent to the clear space unobstructed?</p>	<p><input type="checkbox"/> Yes <input type="checkbox"/> No N/A</p>		<p>Photo #:</p>	<p>• • •</p>
<p>P27 If movement is intended from transfer platforms to levels with elevated play components that are required to be on an accessible route, are transfer steps provided?</p>	<p><input type="checkbox"/> Yes <input type="checkbox"/> No N/A</p>		<p>Photo #:</p>	<p>• • •</p>
<p>P28 Are the transfer steps:</p> <p>At least 14 inches deep?</p> <p>At least 24 inches wide?</p> <p>No higher than 8 inches?</p>	<p><input type="checkbox"/> Yes <input type="checkbox"/> No Measurement: N/A</p> <p><input type="checkbox"/> Yes <input type="checkbox"/> No Measurement: N/A</p> <p><input type="checkbox"/> Yes <input type="checkbox"/> No Measurement: N/A</p>		<p>Photo #:</p>	<p>• • •</p>
<p>P29 Is there at least one means of support for transferring:</p> <p>On and off the platform?</p> <p>Up and down the transfer steps?</p>	<p><input type="checkbox"/> Yes <input type="checkbox"/> No N/A</p> <p><input type="checkbox"/> Yes <input type="checkbox"/> No N/A</p>			<p>• • •</p>

<p>Note: Examples of supports include a rope loop, a loop type handle, a slot in the edge of a flat horizontal or vertical member, poles or bars, or D rings on the corner posts.</p>			Photo #:	
<p>P30 <u>Play Components</u> Is there at least one clear space for a person in a wheelchair to turn around, i.e. a circle at least 60 inches in diameter or a T-shaped space within a 60-inch square, at:</p> <p>Ground level play components on an accessible route? <input type="checkbox"/> Yes <input checked="" type="checkbox"/> No</p> <p>Elevated play components connected by ramps? <input checked="" type="checkbox"/> Yes <input type="checkbox"/> No</p> <p>Note: The turning space is not required at elevated play components connected only by transfer system.</p>	<p>Measurement:</p> <p>Measurement:</p>	<div style="border: 1px solid red; padding: 5px; color: red;"> No current accessible route to ground components. </div>	Photo #:	<ul style="list-style-type: none"> • • •
<p>P31 If there are swings, is there clear space for a person in a wheelchair to turn around, i.e. a circle at least 60 inches in diameter or a T-shaped space within a 60-inch square, immediately adjacent to at least one swing?</p>	<p><input checked="" type="checkbox"/> Yes <input type="checkbox"/> No</p>		Photo #:	<ul style="list-style-type: none"> • • •

<p>P32 Is there a clear ground/floor space at least 30 inches wide and 48 inches long at:</p> <p>Each ground level play component required to be on an accessible route?</p> <p>Each elevated play component required to be on an accessible route that is connected by ramps?</p> <p>Notes: 1. The clear ground space is not required at elevated play components connected only by transfer system. 2. Clear ground spaces 30 inches min by 48 inches min, 60 inch min turning spaces and accessible routes may overlap.</p>	<p><input type="checkbox"/> Yes <input type="checkbox"/> No</p> <p>Measurement: NA</p> <p><input checked="" type="checkbox"/> Yes <input type="checkbox"/> No</p> <p>Measurement:</p>	<p>• ONLY SWINGS AT GROUND SPACE</p> <p>• ONE ELEVATED PLAY COMPONENT</p> <p>• ONE RAMP</p>	<p>Photo #:</p>	<ul style="list-style-type: none"> • • •
<p>P33 If there is a play table for children older than 5 years:</p> <p>Are the tops of rims, curbs, or other obstructions no greater than 31 inches above the ground?</p> <p>Is there clear ground space at least 30 inches wide by at least 48 inches long for a forward approach?</p>	<p><input type="checkbox"/> Yes <input type="checkbox"/> No</p> <p>Measurement: NA</p> <p><input type="checkbox"/> Yes <input type="checkbox"/> No</p> <p>Measurement: NA</p>	<p><u>NO PLAY TABLE</u></p>	<p>Photo #:</p>	<ul style="list-style-type: none"> • • •

<p>Is there clear knee space underneath: At least 17 inches high?</p> <p>Does it extend at least 17 inches deep?</p> <p>Is it least 30 inches wide?</p>	<p><input type="checkbox"/> Yes <input type="checkbox"/> No</p> <p>Measurement: NA</p> <p><input type="checkbox"/> Yes <input type="checkbox"/> No</p> <p>Measurement: NA</p> <p><input type="checkbox"/> Yes <input type="checkbox"/> No</p> <p>Measurement: NA</p>	<p><u>NO PLAY TABLE</u></p>	<p>Photo #:</p>	
<p>P34 If there is a play table for children 5 years or younger:</p> <p>Does it provide knee space as noted above? or Is there clear ground space at least 30 inches wide by at least 48 inches long for a parallel approach?</p>	<p><input type="checkbox"/> Yes <input type="checkbox"/> No</p> <p>NA</p> <p><input type="checkbox"/> Yes <input type="checkbox"/> No</p> <p>Measurement: NA</p>	<p><u>NO PLAY TABLE</u></p>	<p>Photo #:</p>	<ul style="list-style-type: none"> • • •
<p>P35 If a play component on an accessible route requires transfer to entry points or seats:</p> <p>Is the entry point or seat no less than 11 inches and no greater than 24 inches from the clear floor/ground space?</p> <p>Is there at least one means of transfer support?</p>	<p><input type="checkbox"/> Yes <input type="checkbox"/> No</p> <p>Measurement: NA</p> <p><input type="checkbox"/> Yes <input type="checkbox"/> No</p> <p>NA</p>			<ul style="list-style-type: none"> • • •

<p>Note: Examples of supports include a rope loop, a loop type handle, a slot in the edge of a flat horizontal or vertical member, poles or bars, or D rings on the corner posts.</p>			Photo #:	
<p>P36 <u>Ground Surfaces</u> Do ground surfaces inside the play area (on accessible routes, clear ground spaces, and turning spaces) comply with <i>ASTM F 1951-99 Standard Specification for Determination of Accessibility of Surface Systems Under and Around Playground Equipment?</i> Notes: 1. ASTM is the American Society for Testing and Materials. 2 A portable device - the Rotational Penetrometer - measures surface firmness and stability.</p>	<input type="checkbox"/> Yes <input type="checkbox"/> No NA		Photo #:	<ul style="list-style-type: none"> • • •
<p>P37 Do the ground surfaces within use zones (the ground level area beneath and immediately adjacent to a play structure or play equipment that is designated for unrestricted circulation around the play equipment and where it is predicted that a user would</p>	<input checked="" type="checkbox"/> Yes <input type="checkbox"/> No	SLIDES AND LADDERS TO MULCHED GROUND AREA	Photo #:	<ul style="list-style-type: none"> • • •

<p>land when falling from or exiting the play equipment) comply with <i>ASTM F 1292-04 Standard Specification for Impact Attenuation of Surfacing Materials Within the Use Zone of Playground Equipment?</i></p>			<p>Photo #:</p>	
	<p><input type="checkbox"/> Yes <input type="checkbox"/> No</p>		<p>Photo #:</p>	<p>• • •</p>
	<p><input type="checkbox"/> Yes <input type="checkbox"/> No</p>		<p>Photo #:</p>	<p>• • •</p>
	<p><input type="checkbox"/> Yes <input type="checkbox"/> No</p>		<p>Photo #:</p>	<p>• • •</p>
	<p><input type="checkbox"/> Yes <input type="checkbox"/> No</p>		<p>Photo #:</p>	<p>• • •</p>
	<p><input type="checkbox"/> Yes <input type="checkbox"/> No</p>		<p>Photo #:</p>	<p>• • •</p>



ADA Checklist for Existing Facilities

Based on the 2010 ADA Standards for Accessible Design



Produced by

Institute for Human Centered Design

www.HumanCenteredDesign.org

www.ADAchecklist.org

Copyright © 2016



ADA National Network

www.ADAta.org

Questions on the ADA 800-949-4232 voice/tty

Questions on checklist 617-695-0085 voice/tty

ADAinfo@NewEnglandADA.org

This checklist was produced by the New England ADA Center, a project of the Institute for Human Centered Design and a member of the ADA National Network. This checklist was developed under a grant from the Department of Education, NIDRR grant number H133A060092-09A. However the contents do not necessarily represent the policy of the Department of Education, and you should not assume endorsement by the Federal Government.

Questions or comments on the checklist contact the New England ADA Center at 617-695-0085 voice/tty or ADAinfo@NewEnglandADA.org

For the full set of checklists, including the checklists for recreation facilities visit www.ADAchecklist.org.

Copyright © 2016 ADA Checklist for Existing Materials. You can freely reproduce and distribute this content. Include proper attribution. But you must get permission before using this content as a fee-based product.

ADA Checklist for Existing Facilities

The Americans with Disabilities Act (ADA) requires state and local governments, businesses and non-profit organizations to provide goods, services and programs to people with disabilities on an equal basis with the rest of the public.

Some people think that only new construction and alterations need to be accessible and that older facilities are “grandfathered,” but that’s not true. Because the ADA is a civil rights law and not a building code, older facilities are often required to be accessible to ensure that people with disabilities have an equal opportunity to participate.

The ADA has different requirements for state and local governments and for places of public accommodation (businesses and non-profit organizations that serve the public).

Requirements for State and Local Governments

State and local governments must ensure that services, programs and activities, when viewed in their entirety, are accessible to people with disabilities. This is part of public entities’ program accessibility obligations. Alterations to older buildings may be needed to ensure program accessibility. Generally this is a greater obligation than “readily achievable barrier removal” the standard that applies to public accommodations. State and local governments are not required to take any action that would result in undue financial and administrative burdens.

State and local governments’ ADA obligations for program accessibility are in the Department of Justice’s ADA Title II regulations 28 CFR Part 35.150.

How to Use this Checklist

Get Organized

One person can conduct a survey, but it’s easier with two people. One person can take measurements and the other person can fill out the checklist and take photos.

Obtain Floor Plan or Make Sketch

A floor plan helps the surveyors to get organized and to know how many elements there are, such as entrances and toilet rooms. If plans are not available, sketch the exterior and interior layout of interior and exterior spaces and mark the elements on the sketch.

Make Copies of the Checklist

Determine how many copies of each section of the checklist you need. For example, most facilities have more than one toilet room.

Gather Tools

- Checklist
- Clipboard
- Tape measure
- Electronic or carpenter’s level - 24 inches
- Door pressure gauge or fish scale
- Camera
- Bag to hold these items

Requirements for Places of Public Accommodation

Businesses and non-profit organizations that serve the public must remove architectural barriers when it is “readily achievable” to do so; in other words, when barrier removal is “easily accomplishable and able to be carried out without much difficulty or expense.”

The decision of what is readily achievable is made considering the size, type, and overall finances of the public accommodation and the nature and cost of the access improvements needed. Barrier removal that is difficult now may be readily achievable in the future as finances change.

Public accommodations’ ADA obligations for barrier removal are in the Department of Justice’s ADA Title III regulations 28 CFR Part 36.304.

Priorities for Accessibility

The checklist follows the four priorities that are listed in the Department of Justice ADA Title III regulations. These priorities are equally applicable to state and local government facilities.

Priority 1 - Accessible approach and entrance

Priority 2 - Access to goods and services

Priority 3 - Access to public toilet rooms

Priority 4 - Access to other items such as water fountains and public telephones

Conduct the Survey

Start Outside

Start from site arrival points such as drop-off areas and sidewalks. Determine if there is an accessible route to an accessible entrance. If there is a parking lot or garage check for the correct number of accessible parking spaces, including van-accessible spaces. Is there an accessible route from the accessible parking spaces to an accessible entrance? Next survey the entrances. If there is an accessible entrance, determine if there are signs at inaccessible entrances directing people to the accessible entrance. Go inside and continue through the facility.

Keep Good Notes

Write on the front of each checklist where you are surveying. You may end up with six toilet room checklists. When you get back to your office you’ll want to know which one is the checklist for the first floor women’s room. If there isn’t an accessible entrance you’ll want to indicate how many steps there are and how much space is available to install a ramp or lift. This is a good time to take photographs.

Take Good Measurements

When in doubt write it down. It’s better to have too much information than not enough. Even if something is in compliance it’s helpful to have exact measurements.

2010 ADA Standards for Accessible Design

The checklist is based on the 2010 ADA Standards for Accessible Design (2010 Standards). The checklist does not include all sections of the 2010 Standards. For example there are no questions about patient rooms in hospitals or guest rooms in hotels. Consult the 2010 Standards for situations not covered in the checklist. Full compliance with the 2010 Standards is required only for new construction and alterations.

Safe Harbor – Construction Prior to March 15, 2012

Elements in facilities built or altered before March 15, 2012 that comply with the 1991 ADA Standards for Accessible Design (1991 Standards) are not required to be modified to specifications in the 2010 Standards. For example, the 1991 Standards allow 54 inches maximum for a side reach range to a control such as the operating part of a paper towel dispenser. The 2010 Standards lower that side reach range to 48 inches maximum. If a paper towel dispenser was installed prior to March 15, 2012 with the highest operating part at 54 inches, the paper towel dispenser does not need to be lowered to 48 inches.

Elements in the 2010 Standards that aren't in the 1991 Standards

The 2010 Standards contain elements that are not in the 1991 Standards. These elements include recreation facilities such as swimming pools, team and player seating, accessible routes to court sports facilities, saunas and steam rooms, fishing piers, play areas, exercise machines, golf facilities, miniature golf facilities, amusement rides, shooting facilities with firing positions, and recreational boating facilities. Because these elements are not in the 1991 Standards, they are not subject to the safe harbor exemption. State and local governments must make these items



Parking Spaces

Measure from the center of marking lines. If lines are not adjacent to another space or aisle the measurement can be to the full width of the line.



Door Clear Width

Open the door 90 degrees, measure from the face of the door to the edge of the door stop.

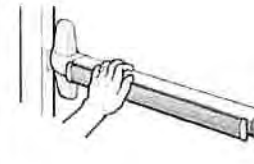

Door Opening Force

Place the door pressure gauge where you would push open the door.

If you're using a fish scale, place it where you would pull open the door.

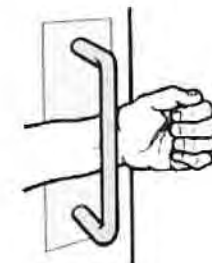

accessible if necessary to ensure program accessibility, unless an undue burden would result. Public accommodations must remove architectural barriers to these items.

What this Checklist is Not

The ADA Title II and III regulations require more than program accessibility and barrier removal. The regulations include requirements for nondiscriminatory policies and practices and for the provision of auxiliary aids and services, such as sign language interpreters for people who are deaf and material in Braille for people who are blind. This checklist does not cover those requirements.

Since this checklist does not include all of the 2010 Standards it is not intended to determine compliance for new construction or facilities being altered.

What are Public Accommodations?

Under the ADA public accommodations are private entities that own, lease, lease to or operate a place of public accommodation. This means that both a landlord who leases space in a building to a tenant and the tenant who operates a place of public accommodation have responsibilities to remove barriers.

A place of public accommodation is a facility whose operations affect commerce and fall within at least one of the following 12 categories:

- 1) Places of lodging (e.g., inns, hotels, motels, except for owner-occupied establishments renting fewer than six rooms)
- 2) Establishments serving food or drink (e.g., restaurants and bars)
- 3) Places of exhibition or entertainment (e.g., motion picture houses, theaters, concert



Accessible Slopes

You can measure slope with a 24 inch level and a tape measure. Put the level on the surface in the direction you are

measuring. Put one end at the high point of the surface and raise the other end so that the bubble is in the middle of the level's gauge. The level is now level. Measure the distance between the end of the level at its bottom point and the surface.

For a ramp the maximum running slope allowed is 1:12. That means for every inch of height change there should be at least 12 inches of ramp run. If the distance between the bottom of the level and the ramp surface is 2 inches or less, then the slope is 1:12 or less ($2:24 = 1:12$ and $1.5:24 = 1:16$ which is a more gradual slope than 1:12). If the distance is greater than 2 inches, the ramp is too steep. For example, if the distance is 3 inches, then the slope is 1:8 ($3:24 = 1:8$ which is a steeper slope than 1:12).

For the parts of an accessible route that aren't a ramp, the maximum running slope allowed is 1:20. That means for every inch of height change there must be at least 20 inches of route run. The distance from the bottom edge of the level to the surface should be no more than 1.2 inches ($1.2:24 = 1:20$).

- halls, stadiums)
- 4) Places of public gathering (e.g. , auditoriums, convention centers, lecture halls)
 - 5) Sales or rental establishments (e.g. , bakeries, grocery stores, hardware stores, shopping centers)
 - 6) Service establishments (e.g. , laundromats, dry-cleaners, banks, barber shops, beauty shops, travel services, shoe repair services, funeral parlors, gas stations, offices of accountants or lawyers, pharmacies, insurance offices, professional offices of health care providers, hospitals)
 - 7) Public transportation terminals, depots, or stations (not including facilities relating to air transportation)
 - 8) Places of public display or collection (e.g. , museums, libraries, galleries)
 - 9) Places of recreation (e.g. , parks, zoos, amusement parks)
 - 10) Places of education (e.g. , nursery schools, elementary, secondary, undergraduate, or postgraduate private schools)
 - 11) Social service center establishments (e.g. , day care centers, senior citizen centers, homeless shelters, food banks, adoption agencies)
 - 12) Places of exercise or recreation (e.g. , gymnasiums, health spas, bowling alleys, golf courses).

For the cross slope of an accessible route the maximum slope allowed is 1:48. The distance from the bottom edge of the level to the surface should be no more than ½ inch (.5:24 = 1:48). The cross slope of an accessible route is the slope that is perpendicular to the direction of pedestrian travel.

Slopes may also be measured using a digital level. Be sure to read the instructions. Measure with the percent calculation rather than the degrees calculation. For a ramp the maximum running slope allowed is 8.33% (8.33% is a 1:12 slope). For an accessible route without a ramp the maximum running slope allowed is 5% (1:20). For the cross slope of an accessible route the maximum slope allowed is 2.083% (1:48).

Check that You Got Everything - Before you leave the site review all the checklists. Make sure you know which checklist goes with which entrance and which toilet room and that you've got all the information you need. It is better to do it now than to have to go back.

After the Survey

List Barriers and Solutions - Consider the solutions listed beside each question on the checklist and add your own ideas. Consult with building contractors and equipment suppliers to estimate the costs for making modifications.

Resources

U.S. Department of Justice ADA Information

800-514-0301 voice
800-514-0383 TTY
www.ada.gov

ADA National Network

800-949-4232 voice/TTY connects to your regional ADA Center
www.adata.org

U.S. Access Board

800- 872-2253 voice
800-993-2822 TTY
www.access-board.gov

ADA Title III Regulations 28 CFR Part 36

www.ada.gov/regs2010/titleIII_2010/titleIII_2010_regulations.htm

2010 ADA Standards for Accessible Design

www.ada.gov/2010ADASTandards_index.htm

1991 ADA Standards for Accessible Design

www.ada.gov/stdspdf.htm

Tax Deductions and Credits for Barrier Removal

www.ada.gov/taxincent.htm

Acknowledgements

Many of the illustrations are from the U.S. Department of Justice and the U.S. Access Board or are based on illustrations produced by the U.S. Access Board and the U.S. Department of Justice.

Develop a Plan – State and local governments were required to develop a Transition Plan a few years after the ADA went into effect. Conducting a current survey is a good opportunity to update the plan.

Although places of public accommodation are not required to have a plan,, the Department of Justice recommends one: *"...Such a plan...could serve as evidence of a good faith effort to comply..."*

Prioritize items, make a timeline, decide who is responsible to carry out the plan and develop a budget.

Make Changes - Use the 2010 ADA Standards for Accessible Design. Check whether local and state building codes require greater accessibility when alterations are undertaken.

Follow Up - Review the plan each year to evaluate whether more access improvements can be made.

ADA Checklist for Existing Facilities

Priority 1 – Approach & Entrance

Based on the 2010 ADA Standards for Accessible Design



Project ADA TRANSITION PLAN

Building LAKE LOUISE PARK GROUND

Location TOWN OF WEAVERVILLE N.C.

Date 5-7-2020

Surveyors ALAN WACKER

Contact Information DALE PENELL

An accessible route from site arrival points and an accessible entrance should be provided for everyone.



Institute for Human Centered Design
www.HumanCenteredDesign.org

Copyright © 2016



ADA National Network
Questions on the ADA 800-949-4232 voice/tty
www.ADAchecklist.org

This checklist was produced by the New England ADA Center, a project of the Institute for Human Centered Design and a member of the ADA National Network. This checklist was developed under a grant from the Department of Education, NIDRR grant number H133A060092-09A. However the contents do not necessarily represent the policy of the Department of Education, and you should not assume endorsement by the Federal Government.

Questions or comments on the checklist contact the New England ADA Center at 617-695-0085 voice/tty or ADAinfo@NewEnglandADA.org

For the full set of checklists, including the checklists for recreation facilities visit www.ADAchecklist.org.

Copyright © 2016 ADA Checklist for Existing Materials. You can freely reproduce and distribute this content. Include proper attribution. But you must get permission before using this content as a fee-based product.

Priority 1 – Approach & Entrance		Comments	Possible Solutions												
<p>1.1 Is there at least one route from site arrival points (parking, passenger loading zones, public sidewalks and public transportation stops) that does not require the use of stairs? [See 2010 ADA Standards for Accessible Design – 206.2.1]</p>	<p><input checked="" type="checkbox"/> Yes <input type="checkbox"/> No</p> <p>If yes, location of route:</p>	<p>PAVEMENT TO HANDICAP RAMP</p>	<ul style="list-style-type: none"> • Add a ramp • Regrade to 1:20 maximum slope • Add a lift if site constraints prevent other solutions 												
<p>Parking Accessible parking spaces should be identified by size, access aisle and signage.</p>															
<p>1.2 If parking is provided for the public, are an adequate number of accessible spaces provided? [208.2]</p>	<p><input checked="" type="checkbox"/> Yes <input type="checkbox"/> No</p> <p>Total #: <u>16</u></p> <p>Accessible #: <u>3</u></p>	<table border="1"> <thead> <tr> <th>Total Spaces</th> <th>Accessible Spaces</th> </tr> </thead> <tbody> <tr> <td>1 - 25</td> <td>1</td> </tr> <tr> <td>26 - 50</td> <td>2</td> </tr> <tr> <td>51 - 75</td> <td>3</td> </tr> <tr> <td>76 - 100</td> <td>4</td> </tr> <tr> <td colspan="2">100+ see 2010 Standards 208.2</td> </tr> </tbody> </table>	Total Spaces	Accessible Spaces	1 - 25	1	26 - 50	2	51 - 75	3	76 - 100	4	100+ see 2010 Standards 208.2		<ul style="list-style-type: none"> • Reconfigure by repainting lines • •
Total Spaces	Accessible Spaces														
1 - 25	1														
26 - 50	2														
51 - 75	3														
76 - 100	4														
100+ see 2010 Standards 208.2															
<p>1.3 Of the accessible spaces, is at least one a van accessible space?*[208.2.4]</p>	<p><input checked="" type="checkbox"/> Yes <input type="checkbox"/> No</p>	<p>*For every 6 or fraction of 6 parking spaces required by the table above, at least 1 should be a van accessible space.</p>	<ul style="list-style-type: none"> * If constructed before 3/15/2012, parking is compliant if at least 1 in every 8 accessible spaces is van accessible • Reconfigure by repainting lines 												

1.4 Are accessible spaces at least 8 feet wide with an access aisle at least 5 feet wide?
[502.2, 502.3]

Note: Two spaces may share an access aisle. Check state/local requirements; some specify that each space have its own aisle.

Yes No

Measurement:
9' WIDE

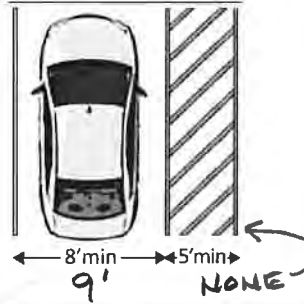

Photo #:

- Reconfigure by repainting lines
-
-

1.5 Is the van accessible space:

At least 11 feet wide with an access aisle at least 5 feet wide?

Or

At least 8 feet wide with an access aisle at least 8 feet wide?

[502.2]

Yes No

Measurement:
12'-4"

Yes No

Measurement:
NA

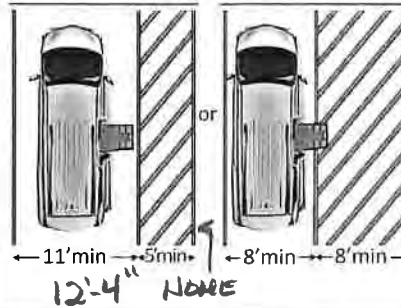

Photo #:

- Reconfigure to provide van-accessible space(s)
-
-

1.6 Is at least 98 inches of vertical clearance provided for the van accessible space?
[502.5]



Yes No



Measurement:
NA

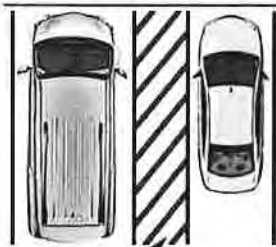

Photo #:

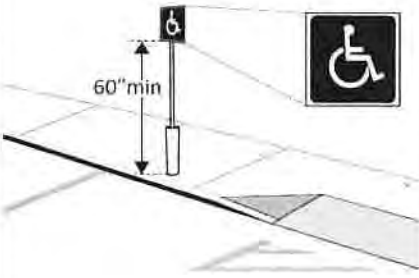
- Reconfigure to provide van-accessible space(s)
-
-

<p>1.7 Are the access aisles marked so as to discourage parking in them? [502.3.3]</p> <p>Note: The marking method and color may be addressed by state/local requirements.</p>	<p><input type="checkbox"/> Yes <input checked="" type="checkbox"/> No</p>	 <p>area to be marked</p>	<p>Photo #:</p>	<ul style="list-style-type: none"> • Mark access aisles • •
<p>1.8 Is the slope of the accessible parking spaces and access aisles no steeper than 1:48 in all directions? [502.4]</p>	<p><input type="checkbox"/> Yes <input type="checkbox"/> No</p> <p>Measurement: 2" in 1'</p>		<p>Photo #:</p>	<ul style="list-style-type: none"> • Regrade surface • •
<p>1.9 Do the access aisles adjoin an accessible route? [502.3]</p>	<p><input type="checkbox"/> Yes <input checked="" type="checkbox"/> No</p>		<p>Photo #:</p>	<ul style="list-style-type: none"> • Create accessible route • Relocate accessible space •
<p>1.10 Are accessible spaces identified with a sign that includes the International Symbol of Accessibility? Is the bottom of the sign at least 60 inches above the ground? [502.6]</p> <p>Note: The International Symbol of Accessibility is not required on the ground.</p>	<p><input type="checkbox"/> Yes <input checked="" type="checkbox"/> No</p> <p><input type="checkbox"/> Yes <input type="checkbox"/> No</p> <p>Measurement: NA NO SIGN</p>	 <p>60" min</p>	<p>Photo #:</p>	<ul style="list-style-type: none"> • Install signs • •

<p>1.11 Are there signs reading “van accessible” at van accessible spaces? [502.6]</p>	<p><input type="checkbox"/> Yes <input checked="" type="checkbox"/> No</p>		<p>Photo #:</p>	<ul style="list-style-type: none"> • Install signs • •
<p>1.12 Of the total parking spaces, are the accessible spaces located on the closest accessible route to the accessible entrance(s)? [208.3.1]</p> <p>Note: If parking serves multiple entrances, accessible parking should be dispersed.</p>	<p><input checked="" type="checkbox"/> Yes <input type="checkbox"/> No</p>	<p>Photo #:</p>	<p>Photo #:</p>	<ul style="list-style-type: none"> • Reconfigure spaces • •
<p>Exterior Accessible Route</p>				
<p>1.13 Is the route stable, firm and slip-resistant? [302.1]</p>	<p><input checked="" type="checkbox"/> Yes <input type="checkbox"/> No</p>	<p>Photo #:</p>	<p>Photo #:</p>	<ul style="list-style-type: none"> • Repair uneven paving • Fill small bumps and breaks with patches • Replace gravel with asphalt or other surface
<p>1.14 Is the route at least 36 inches wide? [403.5.1]</p>	<p><input checked="" type="checkbox"/> Yes <input type="checkbox"/> No</p> <p>Measurement: 64"</p>		<p>Photo #:</p>	<ul style="list-style-type: none"> • Change or move landscaping, furnishings or other items • Widen route •

<p>Note: The accessible route can narrow to 32 inches min. for a max. of 24 inches. These narrower portions of the route must be at least 48 inches from each other.</p>			<p>Photo #:</p>	
<p>1.15 If the route is greater than 200 feet in length and less than 60 inches wide, is there a passing space no less than 60 x 60 inches? [403.5.3]</p>	<p><input type="checkbox"/> Yes <input type="checkbox"/> No</p> <p>Measurement: NA</p>		<p>Photo #:</p>	<ul style="list-style-type: none"> • Widen route for passing space • •
<p>1.16 If there are grates or openings on the route, are the openings no larger than 1/2 inches? Is the long dimension perpendicular to the dominant direction of travel? [302.3]</p>	<p><input type="checkbox"/> Yes <input type="checkbox"/> No</p> <p>Measurement: NA</p> <p><input type="checkbox"/> Yes <input type="checkbox"/> No</p> <p>NA</p>		<p>Photo #:</p>	<ul style="list-style-type: none"> • Replace or move grate • •
<p>1.17 Is the running slope no steeper than 1:20, i.e. for every inch of height change there are at least 20 inches of route run? [403.3]</p> <p>Note: If the running slope is steeper than 1:20, treat as a ramp and add features such as edge protection and handrails.</p>	<p><input checked="" type="checkbox"/> Yes <input checked="" type="checkbox"/> No</p> <p>Measurement: RISE 2" RUN 1'</p> <p style="border: 1px solid red; padding: 2px; display: inline-block;">Treat as Ramp</p>		<p>Photo #:</p>	<ul style="list-style-type: none"> • Regrade to 1:20 max. • •

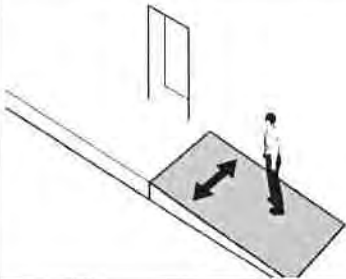
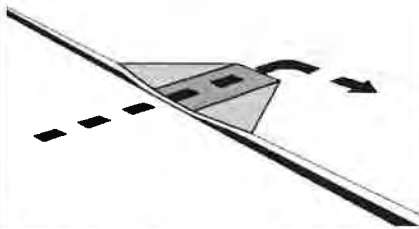
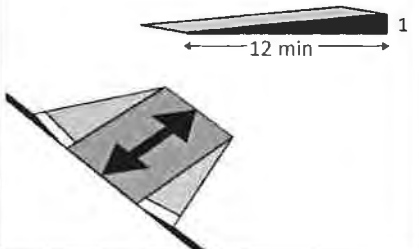
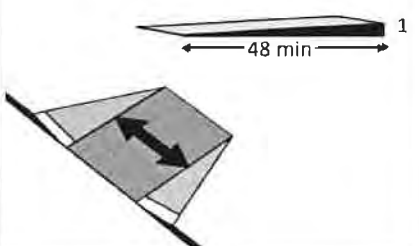
<p>1.18 Is the cross slope no steeper than 1:48? [403.3]</p>	<p><input checked="" type="checkbox"/> Yes <input type="checkbox"/> No</p> <p>Measurement: ZERO</p>		<p>Photo #:</p>	<ul style="list-style-type: none"> • Regrade to 1:48 max. • •
<p>Curb Ramps</p>				
<p>1.19 If the accessible route crosses a curb, is there a curb ramp? [402.2]</p>	<p><input type="checkbox"/> Yes <input type="checkbox"/> No</p> <p><i>NA</i></p>		<p>Photo #:</p>	<ul style="list-style-type: none"> • Install curb ramp • •
<p>1.20 Is the running slope of the curb ramp no steeper than 1:12, i.e. for every inch of height change there are at least 12 inches of curb ramp run? [406.1, 405.2]</p>	<p><input checked="" type="checkbox"/> Yes <input type="checkbox"/> No</p> <p>Measurement: 1" in 12"</p>		<p>Photo #:</p>	<ul style="list-style-type: none"> • Regrade curb ramp • •
<p>1.21 Is the cross slope of the curb ramp, excluding flares, no steeper than 1:48? [406.1, 405.3]</p>	<p><input type="checkbox"/> Yes <input type="checkbox"/> No</p> <p>Measurement: NA</p>		<p>Photo #:</p>	<ul style="list-style-type: none"> • Regrade curb ramp • •

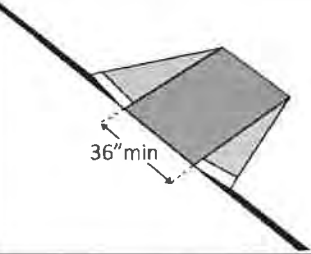
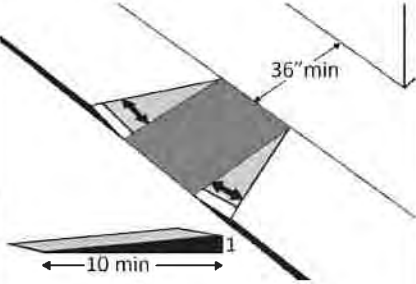
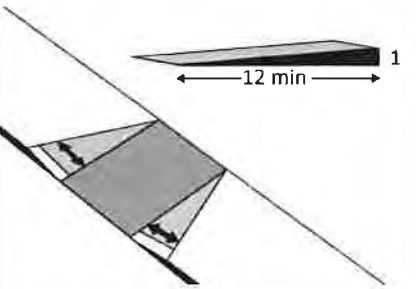
<p>1.22 Is the curb ramp, excluding flares, at least 36 inches wide? [406.1, 405.5]</p>	<p><input type="checkbox"/> Yes <input type="checkbox"/> No</p> <p>Measurement: NA</p>		<p>Photo #:</p>	<ul style="list-style-type: none"> • Widen curb ramp • •
<p>1.23 At the top of the curb ramp is there a level landing (slope no steeper than 1:48 in all directions) that is at least 36 inches long and at least as wide as the curb ramp? [406.4]</p> <p>If there are curb ramp flares, are the slopes of the flares no steeper than 1:10, i.e. for every inch of height change there are at least 10 inches of flare run? [406.3]</p>	<p><input checked="" type="checkbox"/> Yes <input type="checkbox"/> No</p> <p>Measurement: + 36"</p> <p><input type="checkbox"/> Yes <input type="checkbox"/> No</p> <p>Measurement: NA</p>		<p>Photo #:</p>	<ul style="list-style-type: none"> • Reconfigure • Add ramp flares •
<p>1.24 If the landing at the top is less than 36 inches long, are there curb ramp flares?</p> <p>Are the slopes of the flares no greater than 1:12, i.e. for every inch of height change there are at least 12 inches of flare run? [406.4]</p>	<p><input type="checkbox"/> Yes <input type="checkbox"/> No</p> <p>NA</p> <p><input type="checkbox"/> Yes <input type="checkbox"/> No</p> <p>Measurement: NA</p>		<p>Photo #:</p>	<ul style="list-style-type: none"> • Add ramp flares • Regrade flares •

Ramps If any portion of the accessible route is steeper than 1:20, it should be treated as a ramp.

1.25 If there is a ramp is it at least 36 inches wide?
[405.5]

Note: If there are handrails, measure between the handrails.

Yes No

Measurement:
64"

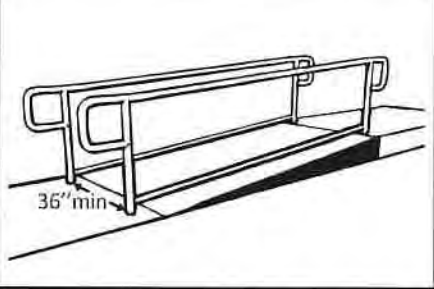

Photo #:

- Alter ramp
-
-

1.26 Is the surface stable, firm and slip resistant?
[405.4]

Yes No



Photo #:

- Resurface ramp
-
-

1.27 For each section of the ramp, is the running slope no greater than 1:12, i.e. for every inch of height change there are at least 12 inches of ramp run?
[405.2]

Note: Rises no greater than 3 inches with a slope no steeper than 1:8 and rises no greater than 6 inches with a slope no steeper than 1:10 are permitted when such slopes are necessary due to space limitations.

Yes No

Measurement:
RISE RUN
2" IN 1'

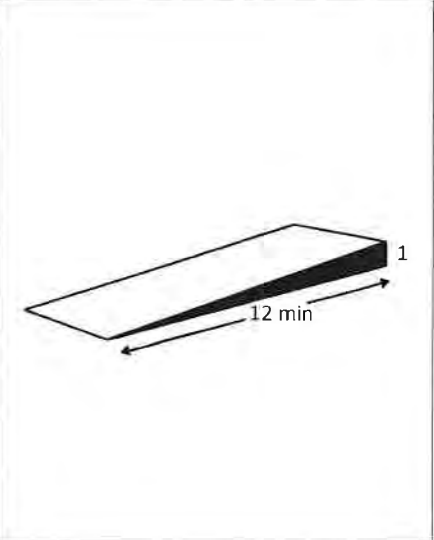
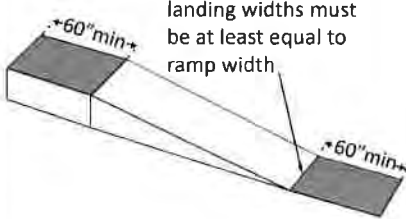
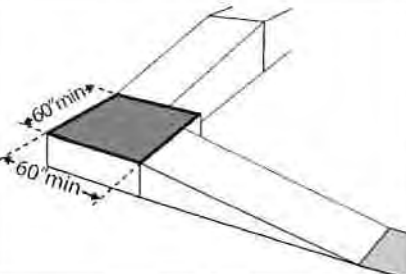
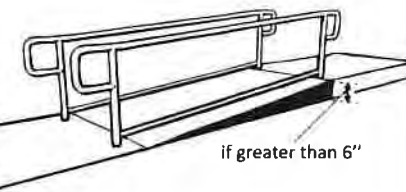
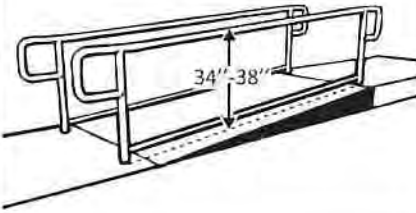
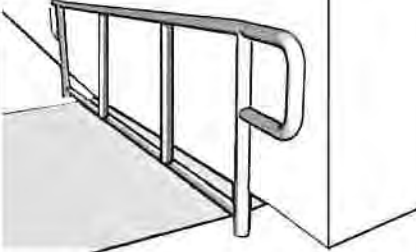
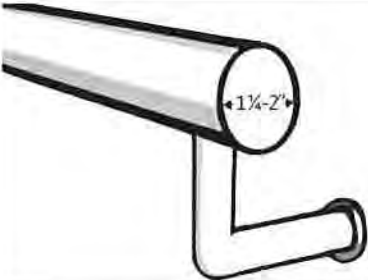
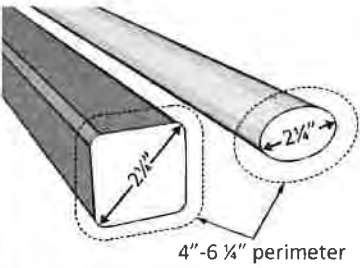
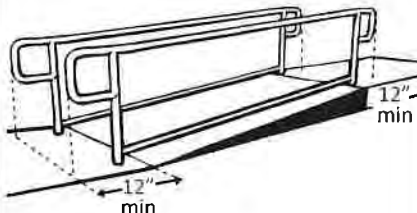
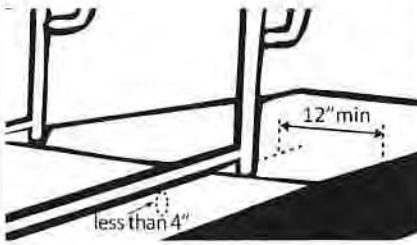

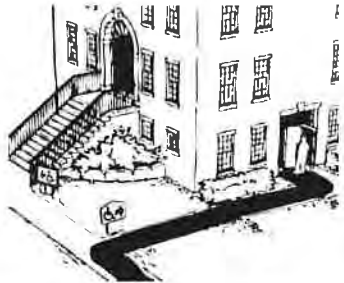

Photo #:

- Relocate ramp
- Lengthen ramp to decrease slope
-

<p>1.28 Is there a level landing that is at least 60 inches long and at least as wide as the ramp:</p> <p>At the top of the ramp?</p> <p>At the bottom of the ramp? [405.7.2, 405.7.3]</p>	<p><input checked="" type="checkbox"/> Yes <input type="checkbox"/> No</p> <p>Measurement: +60"</p> <p><input checked="" type="checkbox"/> Yes <input type="checkbox"/> No</p> <p>Measurement: +60"</p>		<p>Photo #:</p>	<ul style="list-style-type: none"> • Alter ramp • Relocate ramp •
<p>1.29 Is there a level landing where the ramp changes direction that is at least 60 x 60 inches? [405.7.4]</p>	<p><input checked="" type="checkbox"/> Yes <input type="checkbox"/> No</p> <p>Measurement: +60"</p>		<p>Photo #:</p>	<ul style="list-style-type: none"> • Alter ramp • Increase landing size •
<p>1.30 If the ramp has a rise higher than 6 inches, are there handrails on both sides? [405.8]</p> <p>Note: Curb ramps are not required to have handrails.</p>	<p><input type="checkbox"/> Yes <input type="checkbox"/> No</p> <p>Measurement: NA</p>		<p>Photo #:</p>	<ul style="list-style-type: none"> • Add handrails • •

<p>1.31 Is the top of the handrail gripping surface no less than 34 inches and no greater than 38 inches above the ramp surface? [505.4]</p>	<p><input checked="" type="checkbox"/> Yes <input type="checkbox"/> No Measurement: <i>35"</i></p>		<p>Photo #:</p>	<ul style="list-style-type: none"> • Reconfigure or replace handrails • Adjust handrail height •
<p>1.32 Is the handrail gripping surface continuous and not obstructed along the top or sides? [505.3]</p> <p>If there are obstructions, is the bottom of the gripping surface obstructed no greater than 20%? [505.6]</p>	<p><input checked="" type="checkbox"/> Yes <input type="checkbox"/> No <input type="checkbox"/> Yes <input type="checkbox"/> No Measurement: <i>NA</i></p>		<p>Photo #:</p>	<ul style="list-style-type: none"> • Reconfigure or replace handrails • •
<p>1.33 If the handrail gripping surface is circular, is it no less than 1 ¼ inches and no greater than 2 inches in diameter? [505.7.1]</p>	<p><input checked="" type="checkbox"/> Yes <input type="checkbox"/> No Measurement: <i>1 3/4"</i></p>		<p>Photo #:</p>	<ul style="list-style-type: none"> • Replace handrails • •
<p>1.34 If the handrail gripping surface is non-circular:</p> <p>Is the perimeter no less than 4 inches and no greater than 6 ¼ inches?</p>	<p><input type="checkbox"/> Yes <input type="checkbox"/> No Measurement: <i>NA</i></p> <p><input type="checkbox"/> Yes <input type="checkbox"/> No Measurement: <i>NA</i></p>		<p>Photo #:</p>	<ul style="list-style-type: none"> • Replace handrails • •

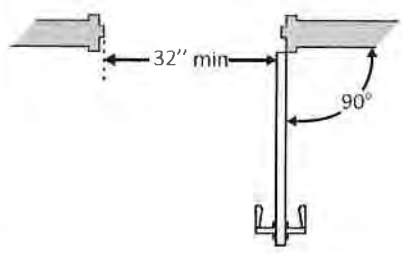
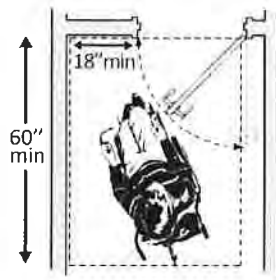
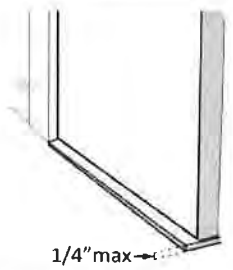

<p>Is the cross section no greater than 2¼ inches? [505.7.2]</p>	<p><input checked="" type="checkbox"/> Yes <input type="checkbox"/> No Measurement: 1 3/4"</p>		<p>Photo #:</p>	
<p>1.35 Does the handrail:</p> <p>Extend at least 12 inches horizontally beyond the top and bottom of the ramp?</p> <p>Return to a wall, guard, or landing surface? [505.10.1]</p> <p>Note: If a 12 inch extension would be a hazard (in circulation path) it is not required.</p>	<p><input checked="" type="checkbox"/> Yes <input type="checkbox"/> No Measurement: 12"</p> <p><input type="checkbox"/> Yes <input type="checkbox"/> No NA</p>		<p>Photo #:</p>	<ul style="list-style-type: none"> • Alter handrails • •
<p>1.36 To prevent wheelchair casters and crutch tips from falling off:</p> <p>Does the surface of the ramp extend at least 12 inches beyond the inside face of the handrail? Or Is there a curb or barrier that prevents the passage of a 4-inch diameter sphere? [405.9.1, 405.9.2]</p>	<p><input type="checkbox"/> Yes <input type="checkbox"/> No Measurement: NA</p> <p><input type="checkbox"/> Yes <input type="checkbox"/> No Measurement: NA</p>		<p>Photo #:</p>	<ul style="list-style-type: none"> • Add curb • Add barrier • Extend ramp width •

Entrance				
<p>1.37 Is the main entrance accessible?</p>	<p><input type="checkbox"/> Yes <input type="checkbox"/> No</p>		<p>Photo #:</p>	<ul style="list-style-type: none"> • Redesign to make it accessible • •
<p>1.38 If the main entrance is not accessible, is there an alternative accessible entrance? Can the alternative accessible entrance be used independently and during the same hours as the main entrance?</p>	<p><input type="checkbox"/> Yes <input type="checkbox"/> No</p>		<p>Photo #:</p>	<ul style="list-style-type: none"> • Designate an entrance and make it accessible • Ensure that accessible entrance can be used independently and during the same hours as the main entrance •
<p>1.39 Do all inaccessible entrances have signs indicating the location of the nearest accessible entrance? [216.6]</p>	<p><input type="checkbox"/> Yes <input type="checkbox"/> No</p>		<p>Photo #:</p>	<ul style="list-style-type: none"> • Install signs • Install signs on route before people get to inaccessible entrances so that people do not have to turn around and retrace route •
<p>1.40 If not all entrances are accessible, is there a sign at the accessible entrance with the International Symbol of Accessibility? [216.6]</p>	<p><input type="checkbox"/> Yes <input type="checkbox"/> No</p>		<p>Photo #:</p>	<ul style="list-style-type: none"> • Install sign • •

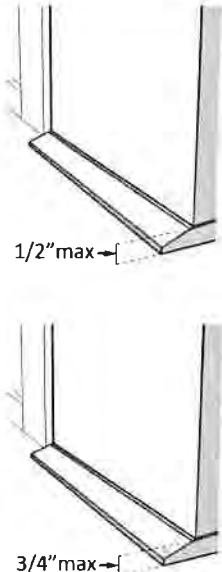
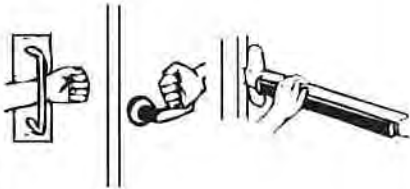
<p>1.41 Is the clear opening width of the accessible entrance door at least 32 inches, between the face of the door and the stop, when the door is open 90 degrees? [404.2.3]</p>	<p><input type="checkbox"/> Yes <input type="checkbox"/> No Measurement: <i>NA</i></p>		<p>Photo #:</p>	<ul style="list-style-type: none"> • Alter door • Install offset hinges •
<p>1.42 If there is a front approach to the pull side of the door, is there at least 18 inches of maneuvering clearance beyond the latch side plus at least 60 inches clear depth?</p> <p>Note: See 2010 Standards 404.2.4 for maneuvering clearance requirements on the push side of the door and side approaches to the pull side of the door</p> <p>On both sides of the door, is the ground or floor surface of the maneuvering clearance level (no steeper than 1:48)? [404.2.4]</p>	<p><input type="checkbox"/> Yes <input type="checkbox"/> No Measurement: <i>NA</i></p> <p><input type="checkbox"/> Yes <input type="checkbox"/> No Measurement: <i>NA</i></p>		<p>Photo #:</p>	<ul style="list-style-type: none"> • Remove obstructions • Reconfigure walls • Add automatic door opener
<p>1.43 If the threshold is vertical is it no more than ¼ inch high?</p> <p>Or</p> <p>No more than ½ inch high with the top ¼ inch beveled no steeper than 1:2, if the threshold was installed on or</p>	<p><input type="checkbox"/> Yes <input type="checkbox"/> No Measurement: <i>NA</i></p> <p><input type="checkbox"/> Yes <input type="checkbox"/> No Measurement: <i>NA</i></p>		<p>Photo #:</p>	<ul style="list-style-type: none"> • Remove or replace threshold • •

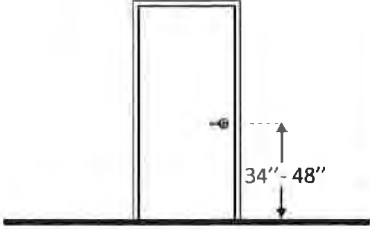
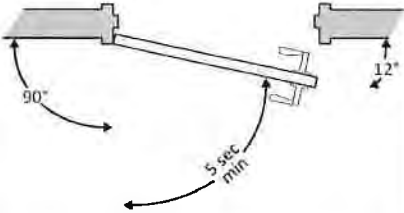
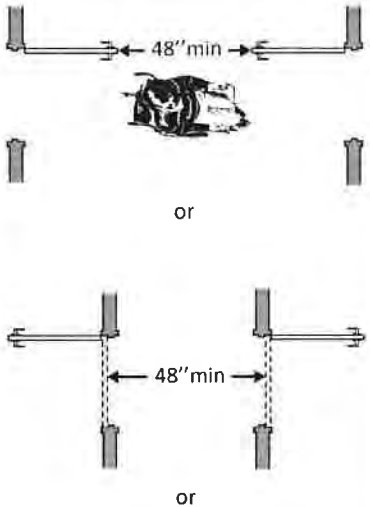
<p>after the 1991 ADA Standards went into effect (1/26/93)?</p> <p>Or</p> <p>No more than 3/4 inch high with the top 1/2 inch beveled no steeper than 1:2, if the threshold was installed before the 1991 ADA Standards went into effect (1/26/93)? [404.2.5, 303.2]</p> <p>Note: The first 1/4 inch of the 1/2 or 3/4 inch threshold may be vertical; the rest must be beveled.</p>	<p><input type="checkbox"/> Yes <input type="checkbox"/> No</p> <p>Measurement:</p> <p><i>NA</i></p>		<p>Photo #:</p>	
<p>1.44 Is the door equipped with hardware that is operable with one hand and does not require tight grasping, pinching or twisting of the wrist?</p> <p>Door handle?</p> <p>Lock (if provided)? [404.2.7]</p>	<p><input type="checkbox"/> Yes <input type="checkbox"/> No</p> <p><i>NA</i></p> <p><input type="checkbox"/> Yes <input type="checkbox"/> No</p> <p><i>NA</i></p> <p><input type="checkbox"/> Yes <input type="checkbox"/> No</p> <p><i>NA</i></p>		<p>Photo #:</p>	<ul style="list-style-type: none"> • Replace inaccessible knob with lever, loop or push hardware • Add automatic door opener •

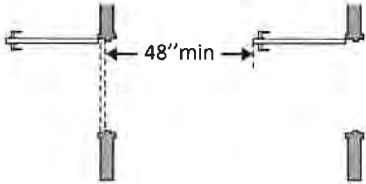
<p>1.45 Are the operable parts of the door hardware no less than 34 inches and no greater than 48 inches above the floor or ground surface? [404.2.7]</p>	<p><input type="checkbox"/> Yes <input type="checkbox"/> No</p> <p>Measurement: <i>N/A</i></p>		<p>Photo #:</p>	<ul style="list-style-type: none"> • Change hardware height • •
<p>1.46 If the door has a closer, does it take at least 5 seconds to close from an open position of 90 degrees to a position of 12 degrees from the latch? [404.2.8]</p>	<p><input type="checkbox"/> Yes <input type="checkbox"/> No</p> <p>Measurement: <i>N/A</i></p>		<p>Photo #:</p>	<ul style="list-style-type: none"> • Adjust closer • •
<p>1.47 If there are two doors in a series, e.g. vestibule, is the distance between the doors at least 48 inches plus the width of the doors when swinging into the space? [404.2.6]</p>	<p><input type="checkbox"/> Yes <input type="checkbox"/> No</p> <p>Measurement: <i>N/A</i></p>		<p>Photo #:</p>	<ul style="list-style-type: none"> • Remove inner door • Change door swing •

			<p>Photo #:</p>	
<p>1.48 If provided at the building entrance, are carpets or mats no higher than ½ inch thick? [302.2]</p>	<p><input type="checkbox"/> Yes <input type="checkbox"/> No</p> <p>Measurement: <i>NA</i></p>		<p>Photo #:</p>	<ul style="list-style-type: none"> • Replace or remove mats • •
<p>1.49 Are edges of carpets or mats securely attached to minimize tripping hazards? [302.2]</p>	<p><input type="checkbox"/> Yes <input type="checkbox"/> No</p> <p><i>NA</i></p>		<p>Photo #:</p>	<ul style="list-style-type: none"> • Secure carpeting or mats at edges • •
	<p><input type="checkbox"/> Yes <input type="checkbox"/> No</p>		<p>Photo #:</p>	<ul style="list-style-type: none"> • • •
	<p><input type="checkbox"/> Yes <input type="checkbox"/> No</p>		<p>Photo #:</p>	<ul style="list-style-type: none"> • • •



TOWN OF WEAVERVILLE

APPENDIX D:

Field Survey Reference

ADA TRANSITION PLAN

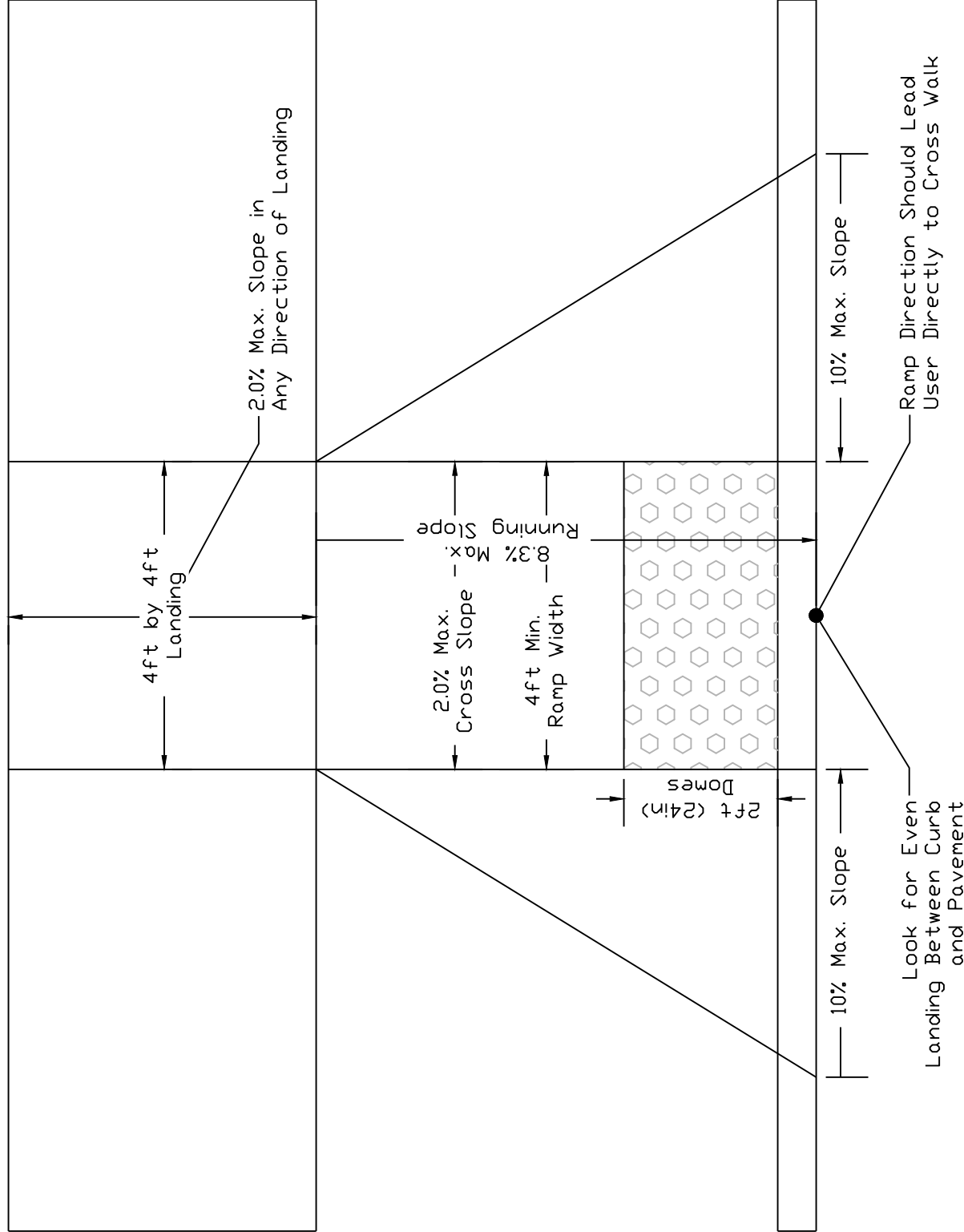

Curb Ramp Checklist

Base Items

1. Ramp Direction Should Lead to Crossing
2. Even Landings (no lips)
3. 4ft (48in) Minimum Ramp Width
4. 8.3% Max. Running Slope
5. 2.0% Max. Crossing Slope
6. 2ft (24in) Wide Detectable Warning Domes (Contrasting Colors from Pavement)
7. 4ft x 4ft Level Landing at Top of Ramp
8. 2.0% Max. Slope in Any Direction of Landing
9. If Curb Ramp Flares Exist, Max. Slope Shall be 10%.

Additional Items

1. Presence of Pedestrian Signal
2. Presence of Pavement Crossing Markings
3. Any Additional Barriers to Ramp Use



TOWN OF WEAVERVILLE

APPENDIX E:

Network Facility Exhibits

ADA TRANSITION PLAN

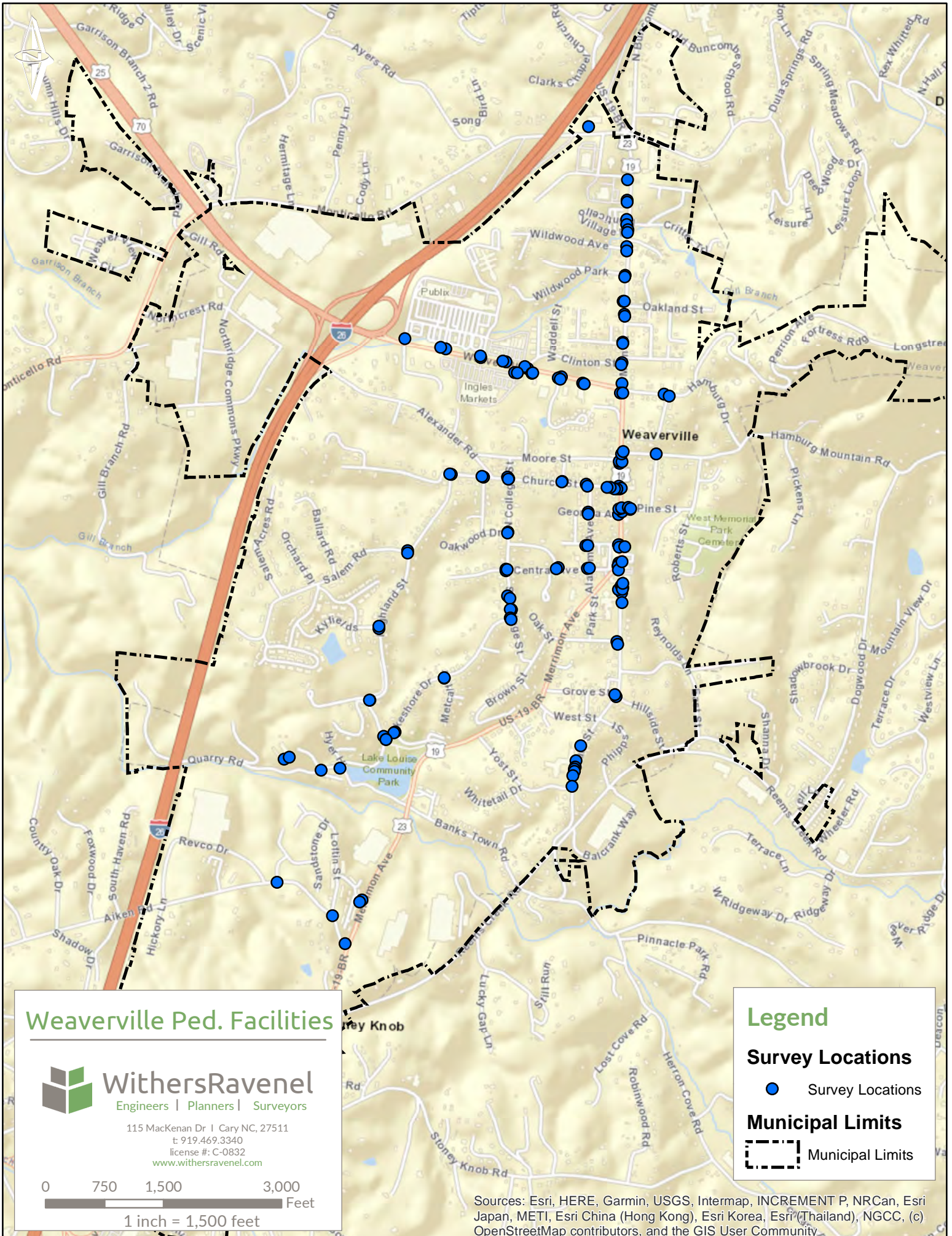

Weaverville Ped. Facilities



WithersRavenel
 Engineers | Planners | Surveyors

115 MacKenan Dr | Cary NC, 27511
 t: 919.469.3340
 license #: C-0832
 www.withersravenel.com

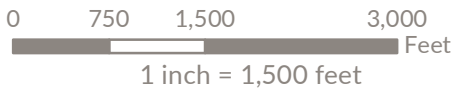

Legend

Survey Locations

● Survey Locations

Municipal Limits

Municipal Limits

Sources: Esri, HERE, Garmin, USGS, Intermap, INCREMENT P, NRCan, Esri Japan, METI, Esri China (Hong Kong), Esri Korea, Esri (Thailand), NGCC, (c) OpenStreetMap contributors, and the GIS User Community

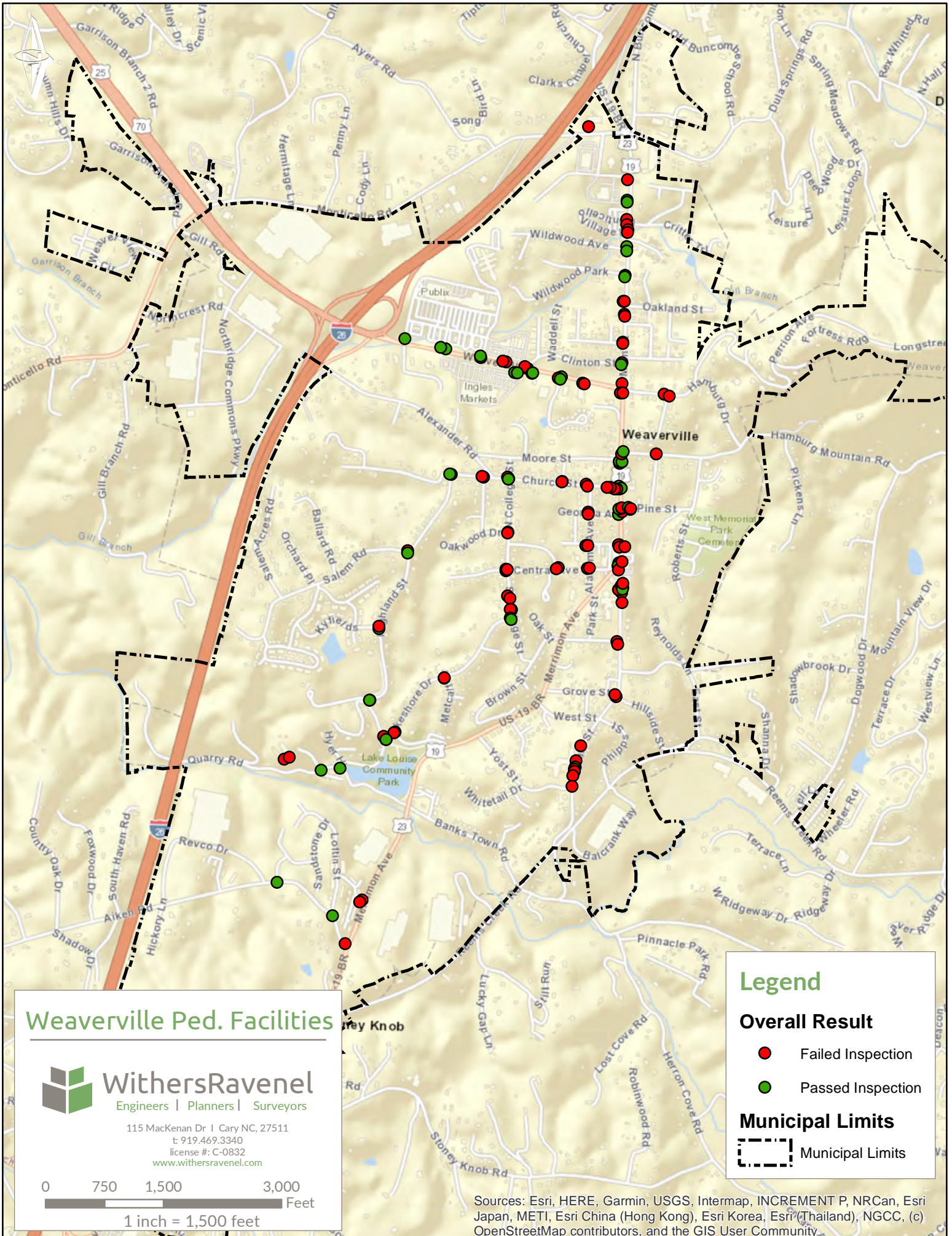

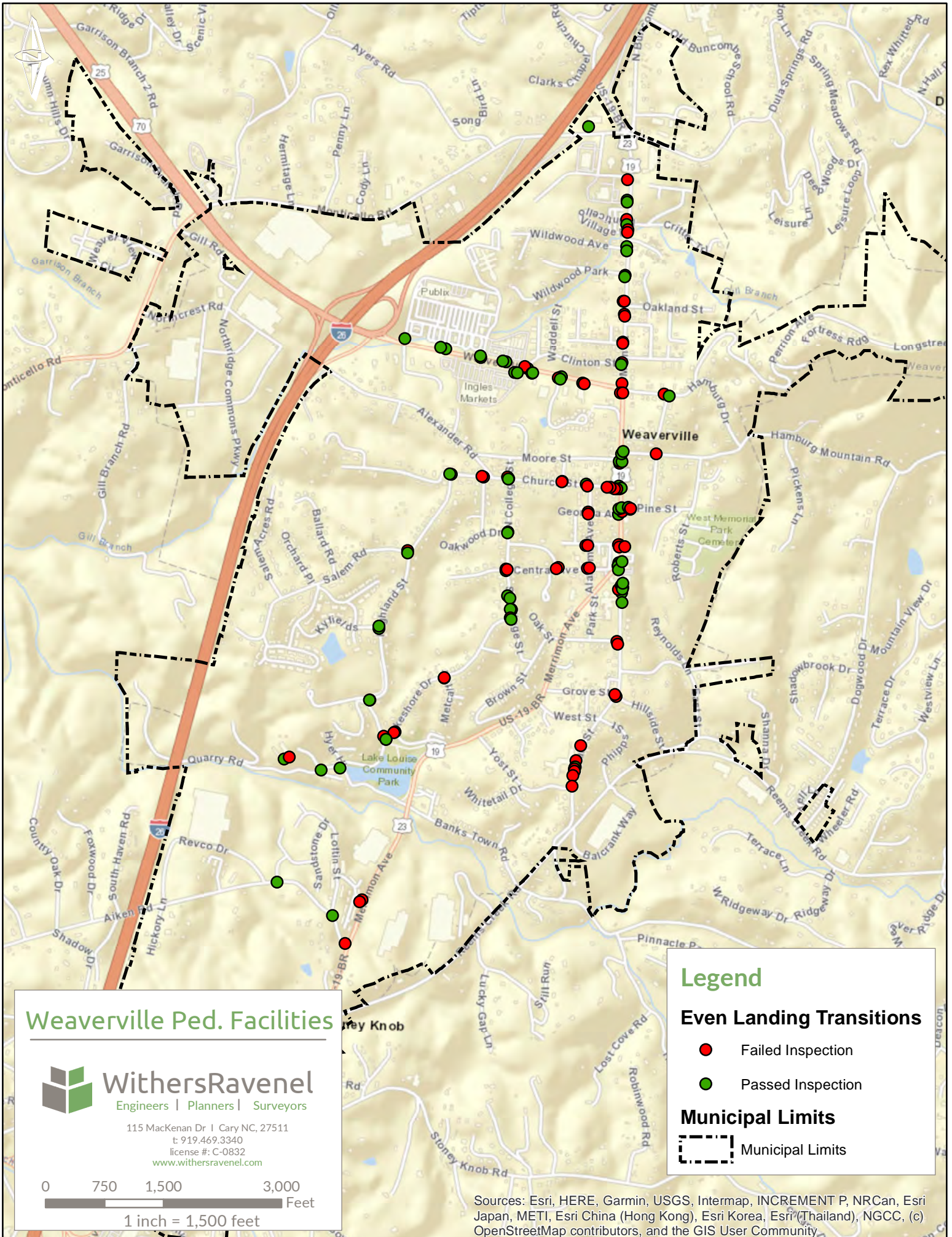

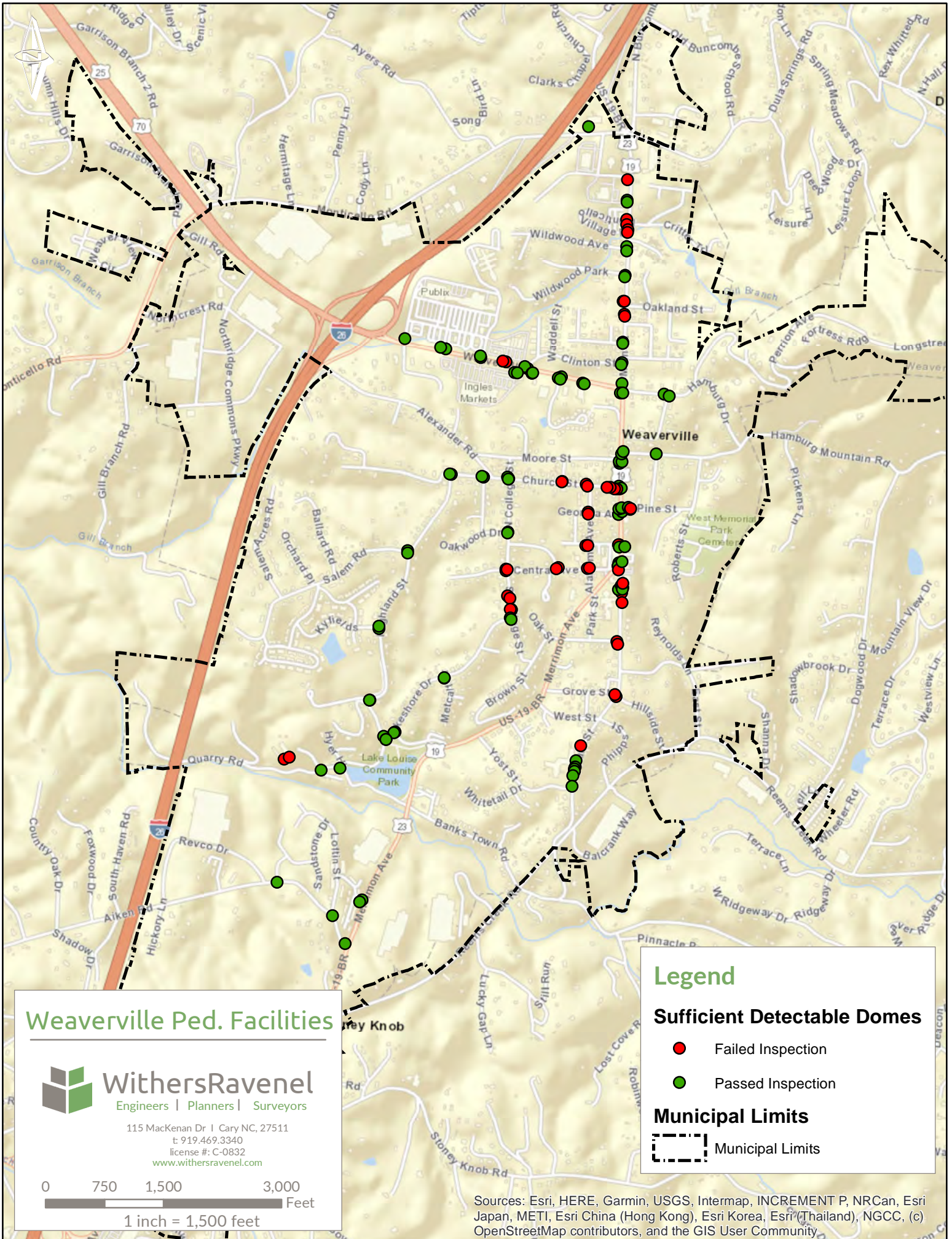

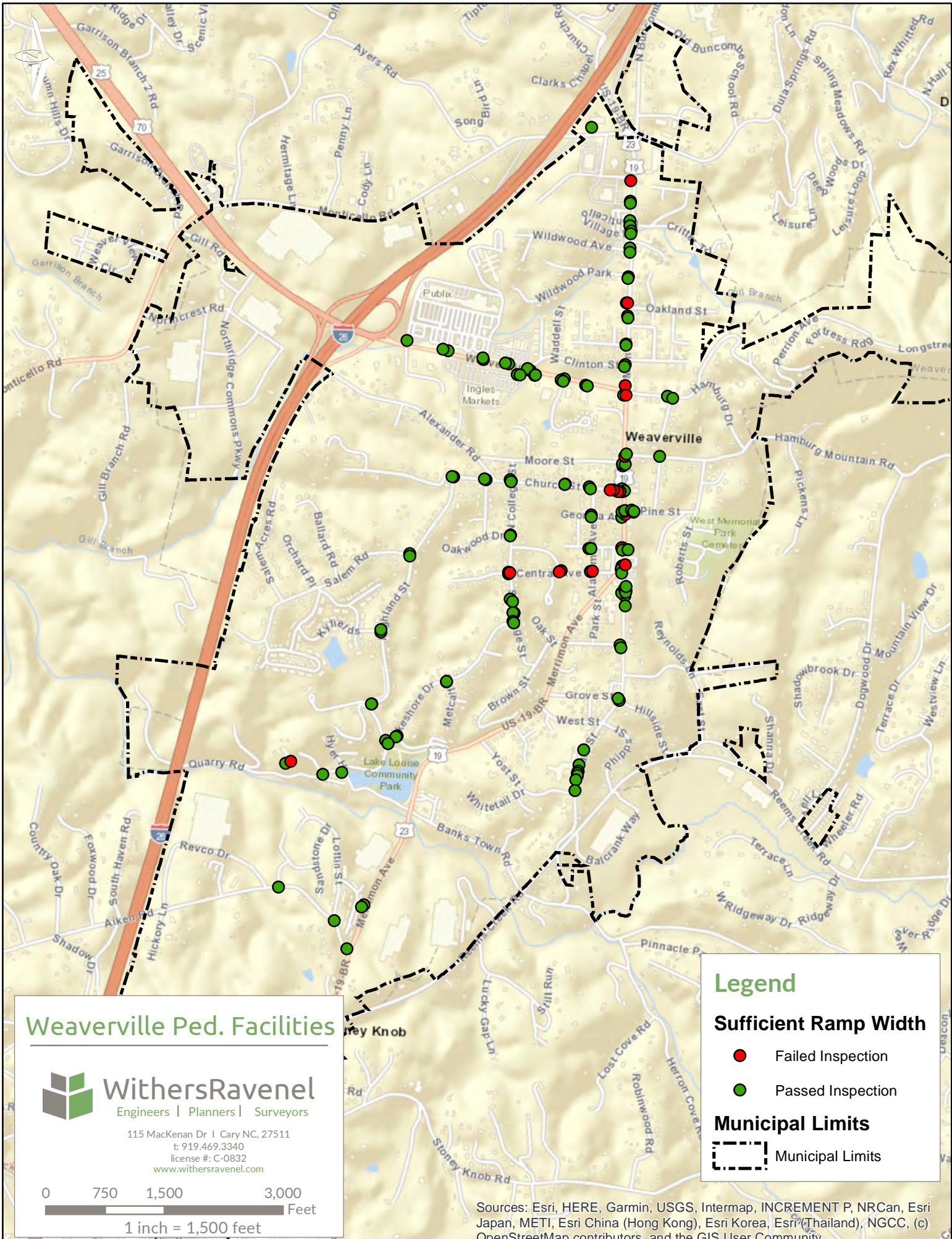

Weaverville Ped. Facilities



WithersRavenel
 Engineers | Planners | Surveyors

115 MacKenan Dr | Cary NC, 27511
 t: 919.469.3340
 license #: C-0832
 www.withersravenel.com

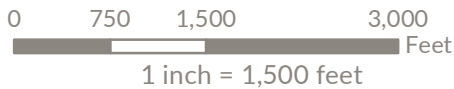

Sources: Esri, HERE, Garmin, USGS, Intermap, INCREMENT P, NRCan, Esri Japan, METI, Esri China (Hong Kong), Esri Korea, Esri (Thailand), NGCC, (c) OpenStreetMap contributors, and the GIS User Community